

stress produced by the transverse forces is manifested in a horizontal shear stress which is accompanied by a vertical shear stress of equal magnitude. The horizontal shear forces are required to keep the member in equilibrium (not moving). Vertical shear strength is generally considered in most design criteria. The formula for vertical shear stress in I- or T-beams is:

$$f_v = \frac{V}{A_w}$$

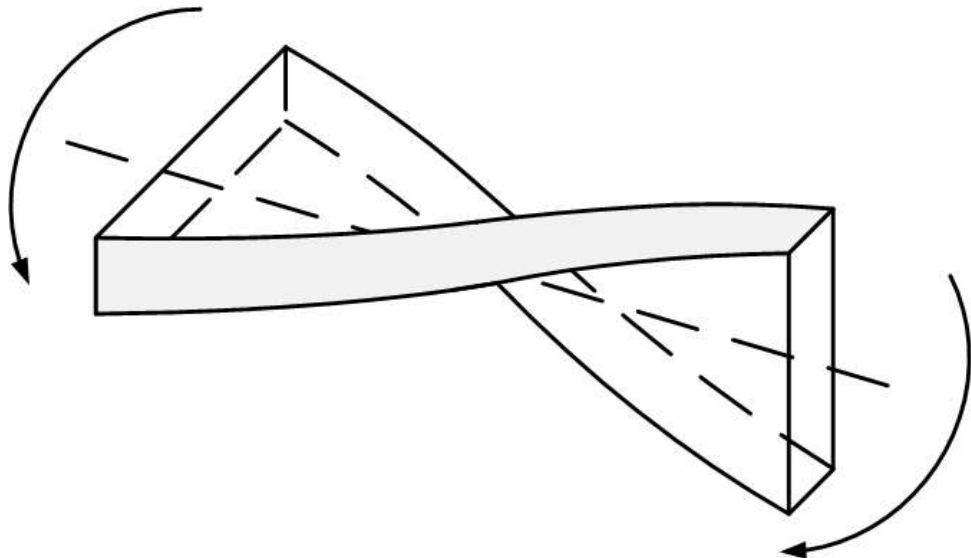
where:  $f_v$  = shear stress (kips per square inch)  
 $V$  = vertical shear due to external loads (kips)  
 $A_w$  = area of web (square inches)

**Torsional Forces**

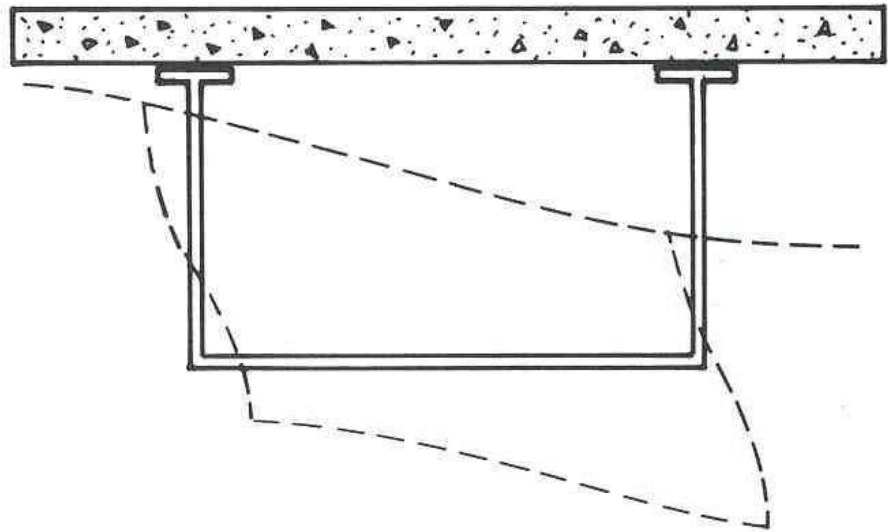
Torsion is a force resulting from externally applied moments which tend to rotate or twist a member about its longitudinal axis. Torsional force is commonly referred to as torque and is generally expressed in English units of pound-feet or kip-feet.

**Example of torsion:** One end of a long rectangular bar is clamped horizontally in a vise so that the long side is up and down. Using a large wrench, a moment is applied to the other end, which causes it to rotate so that the long side is now left to right. The steel bar is resisting a torsional force or torque which has twisted it 90° with respect to its original orientation (see Figure 5.1.13).

Torsional forces develop in bridge members, which are interconnected and experience unbalanced loadings. Bridge elements are generally not designed as torsional members. However, in some bridge superstructures where elements are framed together, torsional forces can occur in longitudinal members. When these members experience differential deflection, adjoining transverse members apply twisting moments resulting in torsion. In addition, curved bridges are generally subject to torsion (see Figure 5.1.14).



**Figure 5.1.13** Torsion

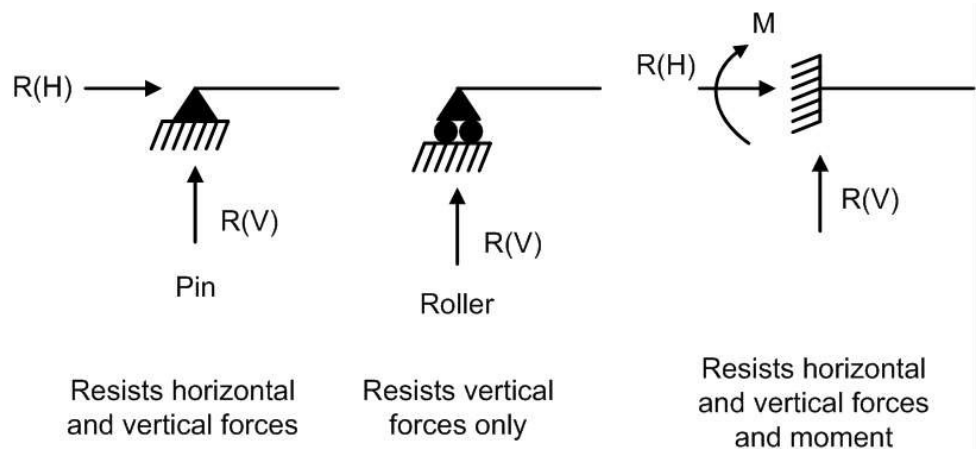


**Figure 5.1.14** Torsional Distortion

**Reactions**

A reaction is a force provided by a support that is equal but opposite to the force transmitted from a member to its support (see Figure 5.1.15). Reactions are most commonly vertical forces, but a reaction can also be a horizontal force. The reaction at a support is the measure of force that it transmits to the ground. A vertical reaction increases as the loads on the member are increased or as the loads are moved closer to that particular support. Reactions are generally expressed in English units of pounds or kips.

**Example of reactions:** Consider a bookshelf consisting of a piece of wood supported at its two ends by bricks. The bricks serve as supports, and the reaction is based on the weight of the shelf and the weight of the books on the shelf. As more books are added, the reaction provided by the bricks will increase. As the books are shifted to one side, the reaction provided by the bricks at that side will increase, while the reaction at the other side will decrease.



**Figure 5.1.15** Types of Supports

The provided reactions at the bridge supports equal the applied permanent or transient loads. The equilibrium keeps the bridge in place.

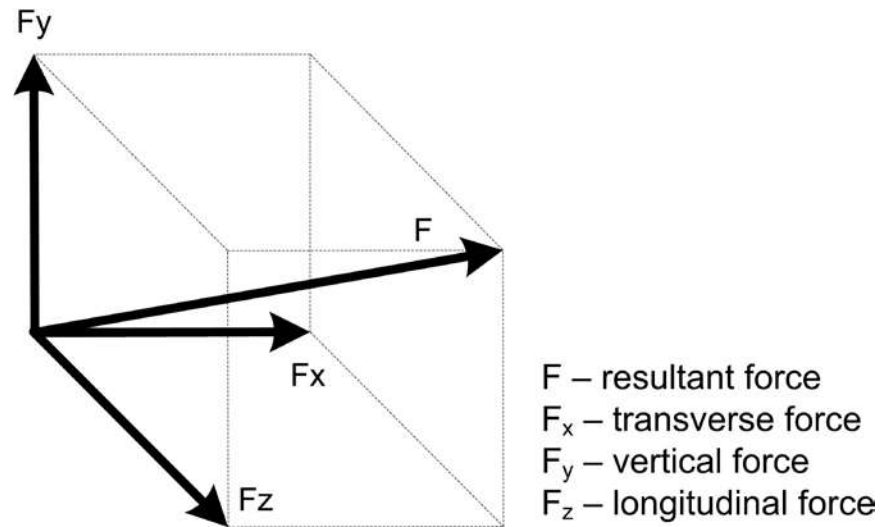
## 5.1.4

### Response to Loadings

Each bridge member has a unique purpose and function, which directly affects the selection of material, shape, and size for that member. Certain terms are used to describe the response of a bridge material to loads. A working knowledge of these terms is essential for the bridge inspector to be effective in their job.

#### Force

A force is the action that one body exerts on another body. Force has three aspects: magnitude, direction and point of application (see Figure 5.1.16). Every force can be divided into 3 distinct components or directions: vertical, transverse, and longitudinal. The combination of these three can produce a resultant force. Forces are generally expressed in English units of pounds or kips.



**Figure 5.1.16** Basic Force Components

#### Stress

Stress is a basic unit of measure used to denote the intensity of an internal force. When a force is applied to a material, an internal stress is developed. Stress is defined as a force per unit of cross-sectional area.

$$\text{Stress } (\sigma) = \frac{\text{Force } (F)}{\text{Area } (A)}$$

The basic English unit of measure for stress is pounds per square inch (abbreviated as psi). However, stress can also be expressed in kips per square inch (ksi) or in any other units of force per unit area. An allowable unit stress is generally established for a given material.

**Example of a stress:** If a 30,000 lb. force acts uniformly over an area of 10 square inches, then the stress caused by this force is 3000 psi (or 3 ksi).

#### Deformation

Deformation is the local distortion or change in shape of a material due to stress.

#### Strain

Strain is a basic unit of measure used to describe an amount of deformation. It denotes the ratio of a material's deformed dimension to a material's original dimensions. For example, strain in a longitudinal direction is computed by dividing the change in length by the original length.

$$\text{Strain } (\varepsilon) = \frac{\text{Change in Length } (\Delta L)}{\text{Original Length } (L)}$$

Strain is a dimensionless quantity. However, it can also be expressed as a percentage or in units of length per length (e.g., inch/inch).

**Example of strain:** If a force acting on a 20 foot long column causes an axial deformation of 0.002 feet, then the resulting axial strain is 0.002 feet divided by 20 feet, or 0.0001 foot/foot. This strain can also be expressed simply as 0.0001 (with no units) or as 0.01%.

### **Elastic Deformation**

Elastic deformation is the reversible distortion of a material. A member is elastically deformed if it returns to its original shape upon removal of the force. Elastic strain is sometimes termed reversible strain because it disappears after the stress is removed. Bridges are designed to deform elastically and return to their original shape after the live loads are removed.

**Example of elastic deformation:** A stretched rubber band will return to its original shape after being released from a taut position. Generally, if the strain is elastic, there is a direct proportion between the amount of strain and the applied stress.

### **Plastic Deformation**

Plastic deformation is the irreversible or permanent distortion of a material. A material is plastically deformed if it retains a deformed shape upon removal of a stress. Plastic strain is sometimes termed irreversible or permanent strain because it remains after the stress is removed. Plastic strain is not directly proportional to the given applied stress as is the case with the elastic strain.

**Example of plastic deformation:** If a car crashed into a brick wall, the fenders and bumpers would deform. This deformation would remain even after the car is backed away from the wall. Therefore, the fenders and bumpers have undergone plastic deformation.

### **Creep**

Creep is a form of plastic deformation that occurs gradually at stress levels normally associated with elastic deformation. Creep is defined as the gradual, continuing irreversible change in the dimensions of a member due to the sustained application of load. It is caused by the molecular readjustments in a material under constant load. The creep rate is the change in strain (plastic deformation) over a certain period of time.

**Example of creep:** If heavy paint cans remain left untouched on a thin wooden shelf for several months, the shelf will gradually deflect and change in shape. This deformation is due to the sustained application of a constant dead load and illustrates the effects of creep.

### Thermal Effects

In bridges, thermal effects are most commonly experienced in the longitudinal expansion and contraction of the superstructure. It is possible to design for deformations caused by thermal effects when members are free to expand and contract. However, there may be members for which expansion and contraction is inhibited or prevented in certain directions. Consider any thermal changes in these members since they can cause significant stresses.

Materials expand as temperature increases and contract as temperature decreases. The amount of thermal deformation in a member depends on:

- A coefficient of thermal expansion, unique for each material
- The temperature change
- The member length

**Example of thermal effects:** Most thermometers operate on the principle that the material within the glass bulb expands as the temperature increases and contracts as the temperature decreases.

### Stress-Strain Relationship

For most structural materials, values of stress and strain are directly proportional (see Figure 5.1.17). However, this proportionality exists only up to a particular value of stress called the elastic limit. Two other frequently used terms, which closely correspond with the elastic limit, are the proportional limit and the yield point.

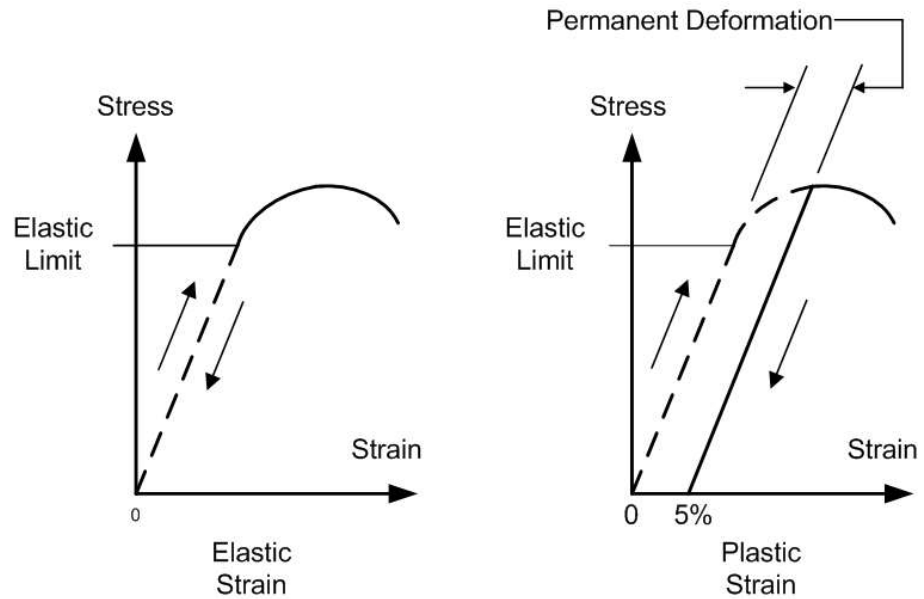
When applying stress up to the elastic limit, a material deforms elastically. Beyond the elastic limit, deformation is plastic and strain is not directly proportional to a given applied stress. The material property, which defines its stress-strain relationship, is called the modulus of elasticity, or Young's modulus.

### Modulus of Elasticity

Each material has a unique modulus of elasticity, which defines the ratio of a given stress to its corresponding strain. It is the slope of the elastic portion of the stress-strain curve.

$$\text{Modulus of Elasticity } (E) = \frac{\text{Stress } (\sigma)}{\text{Strain } (\epsilon)}$$

The modulus of elasticity applies only as long as the elastic limit of the material has not been reached. The units for modulus of elasticity are the same as those for stress (i.e., psi or ksi for English).



**Figure 5.1.17** Stress-Strain Diagram

**Example of modulus of elasticity:** If a stress of 2900 psi is below the elastic limit and causes a strain of 0.0001 in/in, then the modulus of elasticity can be computed based on these values of stress and strain.

$$E = \frac{2,900 \text{ psi}}{0.0001 \text{ in / in}} = 29,000,000 \text{ psi} = 29,000 \text{ ksi}$$

This is approximately equal to the modulus of elasticity for steel. The modulus of elasticity for concrete is approximately 3000 to 4500 ksi, and for commonly used grades of timber it is approximately 1600 ksi.

## Overloads

Overload damage may occur when members are overstressed. Overload occurs when the stresses applied are greater than the elastic limit for the material.

### Buckling

Buckling is the tendency of a member to crush or bend out of plane when subjected to a compressive force. As the length and slenderness of a compression member increases, the likelihood of buckling also increases.

Compression members require additional cross-sectional area or bracing to resist buckling.

**Example of buckling:** A paper or plastic straw compressed axially at both ends with an increasing force will eventually buckle.

### Elongation

Elongation is the tendency of a member to extend, stretch or crack when subjected to a tensile force. Elongation can be either elastic or plastic.

**Example of elongation:** A piece of taffy pulled will stretch in a plastic manner.

### Critical Finding

An overload in a bridge member may be considered a critical finding. Critical findings are presented in Topic 4.5 and defined as “a structural or safety related deficiency that requires immediate follow-up inspection or action.”

**Ductility and Brittleness** Ductility is the measure of plastic (permanent) strain that a material can endure. A ductile material will undergo a large amount of plastic deformation before breaking. It will also have a greatly reduced cross-sectional area before breaking.

**Example of ductility:** A baker working with pizza dough will find that the dough can be stretched a great deal before it will break into two sections. Therefore, pizza dough is a ductile material. When the dough finally does break, it will have a greatly reduced cross-sectional area.

Structural materials for bridges that are generally ductile include:

- Steel
- Aluminum
- Copper
- Wood

Brittle, or non-ductile, materials will not undergo significant plastic deformation before breaking. Failure of a brittle material occurs suddenly, with little or no warning.

**Example of brittleness:** A glass table may be able to support several magazines and books. However, if more and more weight is piled onto the table, the glass will eventually break with little or no warning. Therefore, glass is a brittle material.

Structural materials for bridges that are generally brittle include:

- Concrete
- Cast iron
- Stone
- Fiber Reinforced Polymer

**Fatigue** Fatigue is a material response that describes the tendency of a material to break when subjected to repeated loading. Fatigue failure occurs within the elastic range of a material after a certain number and magnitude of stress cycles have been applied.

Each material has a hypothetical maximum stress value to which it can be loaded and unloaded an infinite number of times. This stress value is referred to as the fatigue limit and is usually lower than the breaking strength for infrequently applied loads.

Ductile materials such as steel and aluminum have high fatigue limits, while brittle materials such as concrete have low fatigue limits. Wood has a high fatigue limit.

**Example of fatigue:** If a rubber band is stretched and then allowed to return to its original position (elastic deformation), it is unlikely that the rubber band will break. However, if this action is repeated many times, the rubber band will eventually break. The rubber band failure is analogous to a fatigue failure.

For a description of fatigue categories for various steel details, refer to Topic 6.4.

### **Isotropy**

A material that has the same mechanical properties regardless of which direction it is loaded is said to be isotropic.

**Example of isotropy:** Plain, unreinforced concrete, and steel.

For a description of isotropic materials, refer to Topics 6.2 and 6.3.

## **5.1.5**

### **Mechanics of Materials**

Materials respond to loadings in a manner dependent on their mechanical properties. In characterizing materials, define certain mechanical properties.

#### **Yield Strength**

The ability of a material to resist plastic (permanent) deformation is called the yield strength. Yield strength corresponds to stress level defined by a material's yield point.

#### **Tensile Strength**

The tensile strength of a material is the stress level defined by the maximum tensile load that it can resist without failure. Tensile strength corresponds to the highest ordinate on the stress-strain curve and is sometimes referred to as the ultimate strength.

#### **Toughness**

Toughness is a measure of the energy required to break a material. It is related to ductility. Toughness is not necessarily related to strength. A material might have high strength but little toughness. A ductile material with the same strength as a non-ductile material will require more energy to break and thus exhibit more toughness. For highway bridges, the CVN (Charpy V-notch) toughness is the toughness value usually used. It is an indicator of the ability of the steel to resist crack propagation in the presence of a notch or flaw. The unit for toughness is ft-lbs @ degrees F.

## **5.1.6**

### **Bridge Movements**

Bridges move because of many factors; some are anticipated, but others are not. Unanticipated movements generally result from settlement, sliding, and rotation of foundations. Anticipated movements include live load deflections, thermal expansions and contractions, shrinkage and creep, earthquakes, rotations, wind drifting, and vibrations. Of these movements, the three major anticipated movements are live load deflections, thermal movements, and rotational movements.

#### **Live Load Deflections**

Deflection produced by live loading should not be excessive because of aesthetics, user discomfort, and possible damage to the whole structure. Several factors control the amount of deflection: strength of material, depth and shape of structural member, and length of a member

In the absence of other criteria, the following limitations may be considered:

Limitations are generally expressed as a deflection-to-span ratio. AASHTO generally limits live load bridge deflection for steel and concrete bridges to 1/800 (i.e., 1-inch vertical movement per 800 feet of span length). For bridges that have sidewalks, AASHTO limits live load bridge deflection to 1/1000 (i.e., 1-inch vertical movement per 1000 feet of span length).



**Thermal Movements** The longitudinal expansion and contraction of a bridge is dependent on the range of temperature change, material, and most importantly, length of bridge used in construction. Thermal movements are frequently accommodated using expansion joints and movable bearings. To accommodate thermal movements, it is recommended the designer allow 1-1/4 inches of movement for each 100 feet of span length for steel bridges and 1-3/16 inches of movement for each 100 feet of span length for concrete bridges.

**Rotational Movements** Rotational movement in bridges is a direct result of live load deflection and occurs with the greatest magnitude at the bridge supports. This movement can be accommodated using bearing devices that permit rotation.

### 5.1.7

---

**Design Methods** Bridge engineers use various design methods that incorporate safety factors to account for uncertainties and random deviations in material strength, fabrication, construction, durability, and loadings.

**Allowable Stress Design** The Allowable Stress Design (ASD) or Working Stress Design (WSD) is a method in which the maximum stress a particular member may carry is limited to an allowable or working stress. The allowable or working stress is determined by applying an appropriate factor of safety to the limiting stress of the material. For example, the allowable tensile stress for a steel tension member is 0.55 times the steel yield stress. This results in a safety factor of 1.8. The capacity of the member is based on either the inventory rating level or the operating rating level. AASHTO currently has ten possible WSD group loadings. See Topic 5.1.8 for inventory and operating rating levels.

**Load Factor Design** Load Factor Design (LFD) is a method in which the ultimate strength of a material is limited to the combined effect of the factored loads. The factored loads are determined from the applied loadings, which are increased by selected multipliers that provide a factor of safety. The load factors for AASHTO Group I are  $1.3(DL+1.67(LL+I))$ . AASHTO currently has ten possible LFD group loadings.

**Load and Resistance Factor Design** Load and Resistance Factor Design (LRFD) is a design procedure based on the actual strength, rather than on an arbitrary calculated stress. It is an ultimate strength concept where both working loads and resistance are multiplied by factors, and the design performed by assuming the strength exceeds the load. (The load multipliers used in LRFD are not the same multipliers that are used in LFD.)

These design methods are conservative due to safety factors and limit the stress in bridge members to a level well within the material's elastic range, provided that the structural members are in good condition. That is why it is important for inspectors to accurately report any deficiency found in the members.

### 5.1.8

---

**Bridge Load Ratings** One of the primary functions of a bridge inspection is to collect information necessary for a bridge load capacity rating. Therefore, understand the principles of bridge load ratings. Bridge load rating methods and guidelines are provided by AASHTO in the *AASHTO Manual for Bridge Evaluation*.

A bridge load rating is used to determine the usable live load capacity of a bridge. Each member of a bridge has a unique load rating, and the bridge load rating represents the most critical one. Bridge load rating is generally expressed in units of tons, and it is computed based on the following basic formula:

$$\text{Bridge Rating Factor (RF)} = \frac{C - A_1 D}{A_2 L(1 + I)}$$

where: RF= the rating factor for the live-load carrying capacity; the rating factor multiplied by the rating vehicle in tons gives the rating of the structure  
 C = the capacity of the member  
 D = the dead load effect on the member  
 L = the live load effect on the member  
 I = the impact factor to be used with the live load effect  
 A<sub>1</sub> = factor for dead loads  
 A<sub>2</sub> = factor for live loads

Bridge load rating for Load and Resistance Factor Rating (LRFR) is computed based on the following basic formula:

$$\text{Bridge Rating Factor (RF)} = \frac{C - (\gamma_{DC})(DC) - (\gamma_{DW})(DW) \pm (\gamma_P)(P)}{(\gamma_L)(LL + IM)}$$

where: RF= rating factor  
 C = capacity  
 DC = dead load effect due to structural components and attachments  
 DW= dead load effect due to wearing surface and utilities  
 P = permanent load other than dead loads  
 LL = live load effect  
 IM = dynamic load allowance  
 $\gamma_{DC}$  = LRFD load factor for structural components and attachments  
 $\gamma_{DW}$  = LRFD load factor for wearing surfaces and utilities  
 $\gamma_P$  = LRFD load factor for permanent loads other than dead loads = 1.0  
 $\gamma_L$  = evaluation live-load factor

Both of the formulas above determine a rating factor for the controlling member of the bridge. For either case, the safe load capacity in tons can be calculated as follows:

$$RT = RF \times W$$

where: RT= rating in tons for truck used in computing live-load effect  
 RF= rating factor  
 W = weight in tons of truck used in computing live-load effect

Note that when LRFR lane loading controls the rating, the equivalent truck weight (W) to be used in calculating the safe load capacity in tons is 40 tons.

### **Inventory Rating**

The inventory rating level generally corresponds to the customary design level of stresses but reflects the existing bridge and material conditions with regard to deterioration and loss of section. Load ratings based on the inventory level allow comparisons with the capacity for new structures and, therefore, results in a live load, which can safely utilize an existing structure for an indefinite period of time. For the allowable stress method, the inventory rating for steel used to be based on 55% of the yield stress. Inventory ratings have been refined to reflect the various material and load types. See the *AASHTO Manual for Bridge Evaluation* (Section 6B.6.2 for Allowable Stress Inventory Ratings and Section 6B.6.3 for Load Factor Inventory Ratings).

The LRFD design level is comparable to the traditional Inventory rating. Bridges that pass HL-93 screening at the Inventory level are capable of carrying AASHTO legal loads and state legal loads within the AASHTO exclusion limits described in the *LRFD Bridge Design Specifications*.

### **Operating Rating**

Load ratings based on the operating rating level generally describe the maximum permissible live load to which the structure may be subjected. Allowing unlimited numbers of vehicles to use the bridge at operating level may shorten the life of the bridge. For steel, the allowable stress for operating rating used to be 75% of the yield stress. Operating ratings have been refined to reflect the various material and load types. See the *AASHTO Manual for Bridge Evaluation* (Section 6B.6.2 for Allowable Stress Operating Ratings and Section 6B.6.3 for Load Factor Operating Ratings).

### **Permit Loading**

Special permits for heavier than normal vehicles may occasionally be issued by a governing agency. The load produced by the permit vehicle is to not exceed the structural capacity determined by the operating rating.

The second level rating is a legal load rating providing a single safe load capacity for a specific truck configuration. The second level rating is comparable to the traditional Operating rating. Bridges that pass HL-93 screening at the Operating level are capable of carrying AASHTO legal loads, but may not rate for state legal loads especially those that are considerably heavier than AASHTO trucks.

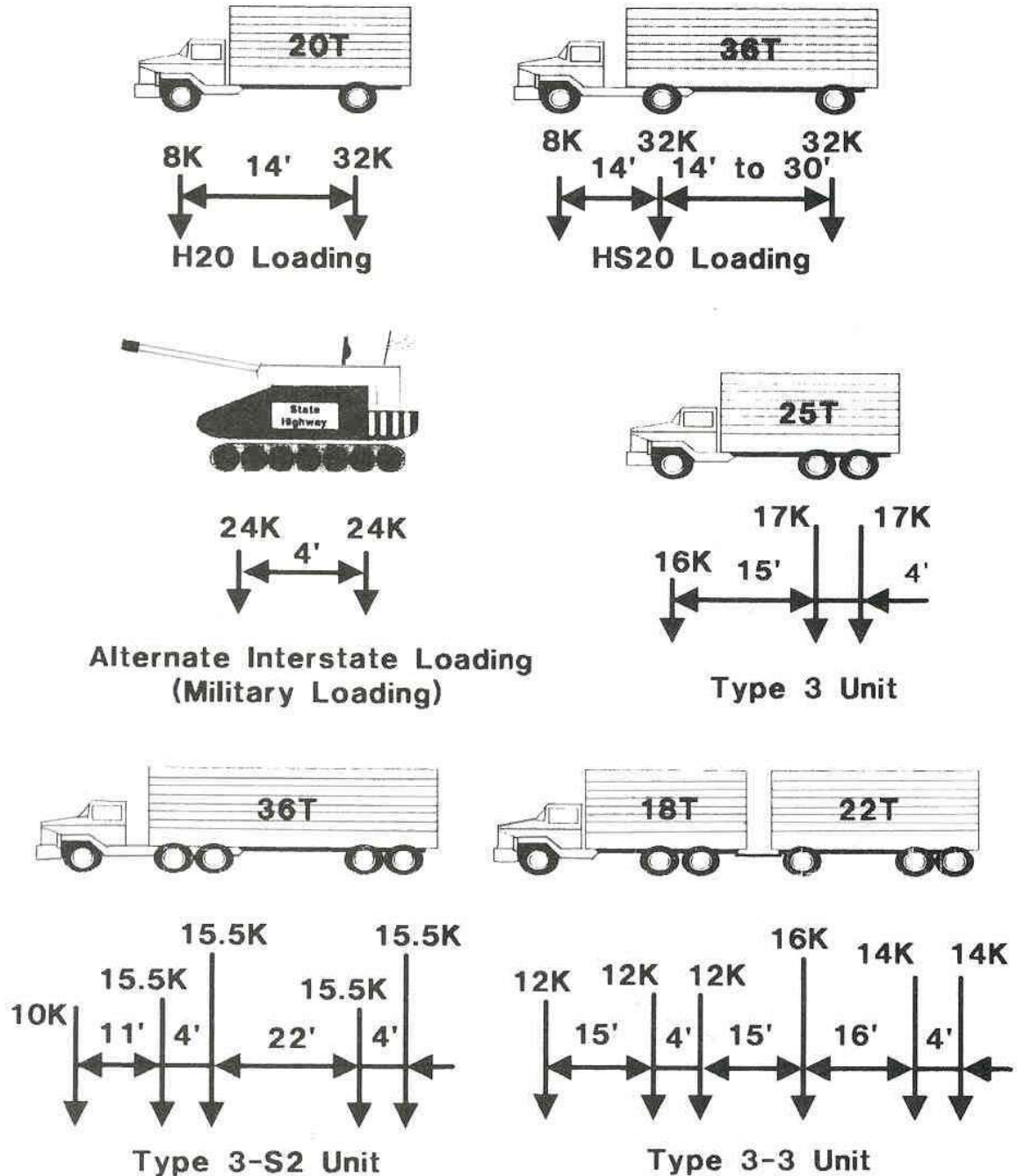
The third level rating is used to check the serviceability and safety of bridges in the review of permit applications. Permits are required for vehicles above the legal load. Only apply this third level rating to bridges with sufficient capacity for AASHTO legal loads. Calibrated load factors by permit type and traffic conditions are specified for checking the effect of the overweight vehicle. Guidance on checking serviceability criteria are also given.

### **Rating Vehicles**

Rating vehicles are truck loads applied to the bridge to establish the inventory and operating ratings. These rating vehicles (see Figure 5.1.18) include:

- H loading
- HS loading
- HL-93
- Alternate Interstate Loading (Military Loading)
- Type 3 unit
- Type 3-S2 unit

- Type 3-3 unit
- The maximum legal load vehicles of the state
- State routine permit loads



**Figure 5.1.18** Rating Vehicles

The axle spacing and weights of the Type 3 unit, Type 3-S2 unit, and Type 3-3 unit are based on actual vehicles. However, as described previously, the H and HS loadings do not represent actual vehicles.

These standard rating vehicles were chosen based on load regulations of most states and governing agencies. However, individual states and agencies may also establish their own unique rating vehicles.

## Bridge Posting

Bridge loads are posted to warn the public of the load capacity of a bridge, to avoid safety hazards, and to adhere to federal law. Federal regulation requires highway bridges on public roads to be inspected every twenty-four months for lengths greater than 20 feet. Post or restrict the bridge in accordance with the AASHTO Manual or in accordance with State law, when the maximum unrestricted legal loads or State routine permit loads exceed that allowed under the operating rating or equivalent rating factor.. It is the inspector's responsibility to gather and provide information that the structural engineer can use to analyze and rate the bridge.

The safe load-carrying capacity of a bridge considers the following criteria:

- Physical condition
- Potential for fatigue damage
- Type of structure/configuration
- Truck traffic data (include State legal loads and routine permit loads)

Bridge postings show the maximum allowable load by law for single vehicles and combinations while still maintaining an adequate safety margin (see Figure 5.1.19).



**Figure 5.1.19** Bridge Weight Limit Posting

Failure to comply with bridge posting may result in fines, tort suits/financial liabilities, accidents, or even death. In addition, bridges may be damaged when postings are ignored (see Figure 5.1.20).



**Figure 5.1.20** Damaged Bridge due to Failure to Comply with Bridge Posting

## 5.1.9

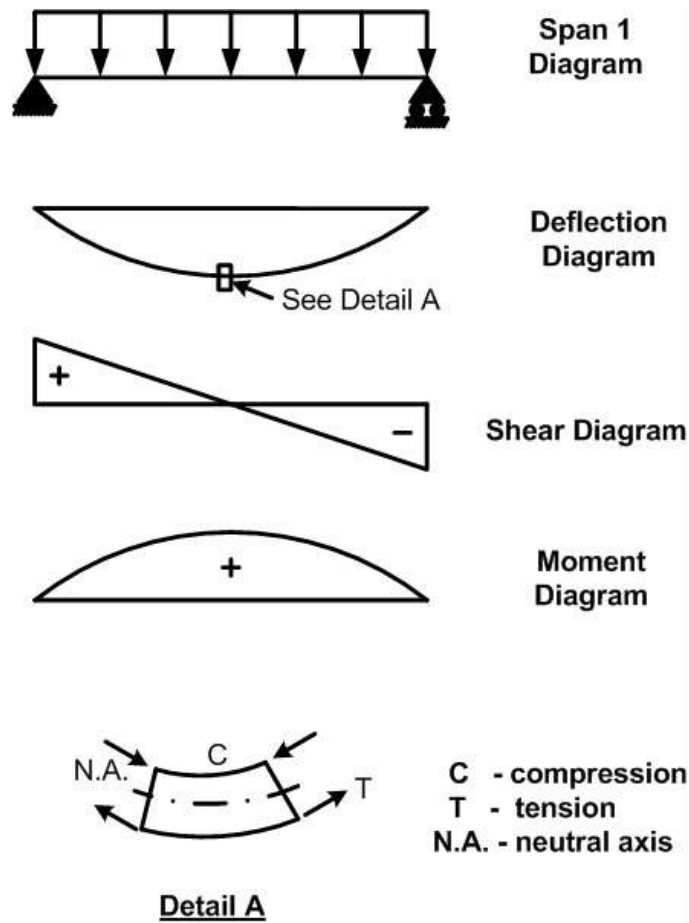
### **Span Classifications**

Bridges are classified into three span classifications that are based on the nature of the supports and the interrelationship between spans. These classifications are:

- Simple
- Continuous
- Cantilever

**Simple**

A simple span is a span with only two supports, each of which is at or near the end of the span (see Figure 5.1.21).



**Figure 5.1.21** Simple Bridge

A simple span bridge can have a single span supported at the ends by two abutments or multiple spans with each span behaving independently of the others. Some characteristics of simple span bridges are:

- When loaded, the span deflects downward and rotates at the supports
- The sum of the reactions provided by the two supports equals the entire load
- Shear forces are maximum at the supports and zero at or near the middle of the spans
- Bending moment throughout the span is positive and maximum at or near the middle of the span (the same location at which shear is zero); bending moment is zero at the supports
- The part of the superstructure below the neutral axis is in tension while the portion above the neutral axis is in compression

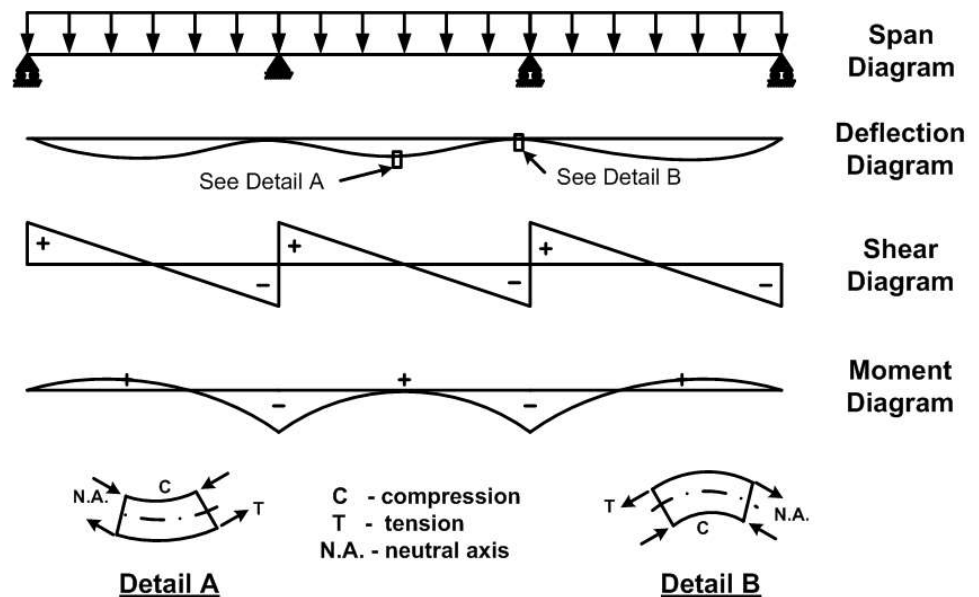
A simple span bridge is easily analyzed using equilibrium equations. However, it does not always provide the most economical design solution.

## Continuous

A continuous span is a configuration in which a bridge has one or more intermediate supports and the behavior of each individual span is dependent on its adjacent spans (see Figure 5.1.22).

A continuous span bridge is one which is supported at the ends by two abutments and which spans uninterrupted over one or more intermediate supports. Some characteristics of continuous span bridges are:

- When loaded, the spans deflect downward and rotate at the supports
- The reactions provided by the supports depend on the span configuration and the distribution of the loads
- Shear forces are maximum at the supports and zero at or near the middle of the spans
- Positive bending moment is greatest at or near the middle of each span
- Negative bending moment is greatest at the intermediate supports; the bending moment is zero at the end supports; there are also two locations per intermediate support at which bending moment is zero, known as inflection points
- For positive bending moments, compression occurs on the top portion of the bridge member and tension occurs on the bottom portion of the bridge member
- For negative bending moments, tension occurs on the top portion of the bridge member and compression occurs on the bottom portion of the bridge member



**Figure 5.1.22** Continuous Bridge

A continuous span bridge allows longer spans and is more economical than a bridge consisting of many simple spans. This is due to its efficient design with members that are shallower. However, a continuous bridge is more difficult to analyze than a simple span bridge and is more susceptible to overstress conditions if the supports experience differential settlement.

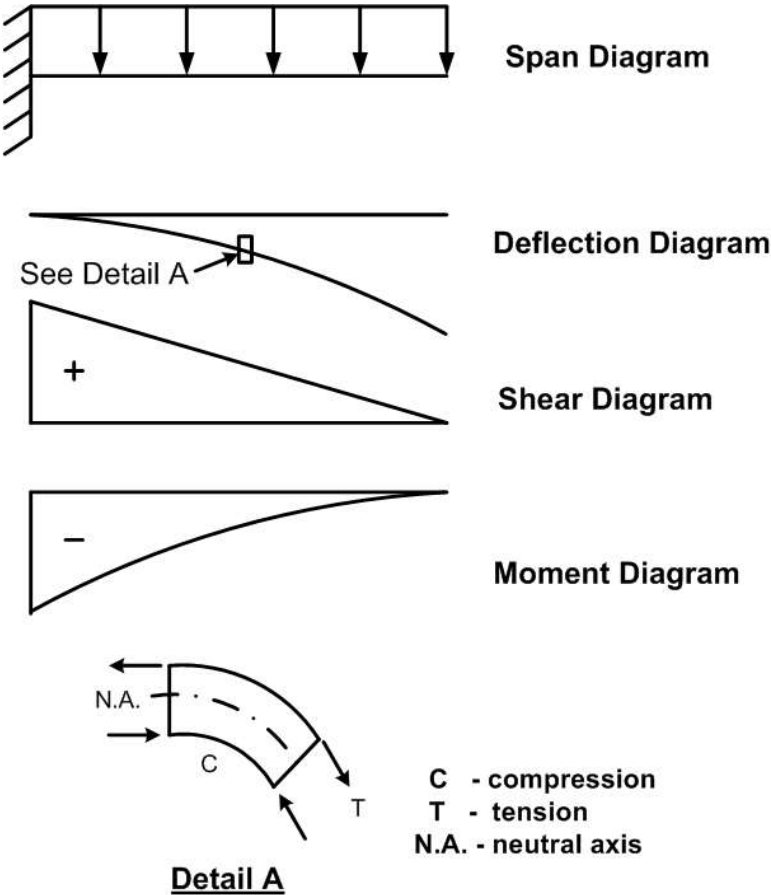


**Cantilever**

A cantilever span is a span with one end restrained against rotation and deflection and the other end completely free (see Figure 5.1.23). The restrained end is also known as a fixed support.

While a cantilever generally does not form an entire bridge, portions of a bridge can behave as a cantilever (e.g., cantilever bridges and bascule bridges). Some characteristics of cantilevers are:

- When loaded, the span deflects downward, but there is no rotation or deflection at the support
- The fixed support reaction consists of a vertical force and a resisting moment
- The shear is maximum at the fixed support and is zero at the free end
- The bending moment throughout the span is negative and maximum at the fixed support; bending moment is zero at the free end



**Figure 5.1.23** Cantilever Span

When cantilever spans are incorporated into a bridge, they are generally extensions of a continuous span. Therefore, moment and rotation at the cantilever support will be dependent on the adjacent span (see Figure 5.1.24).

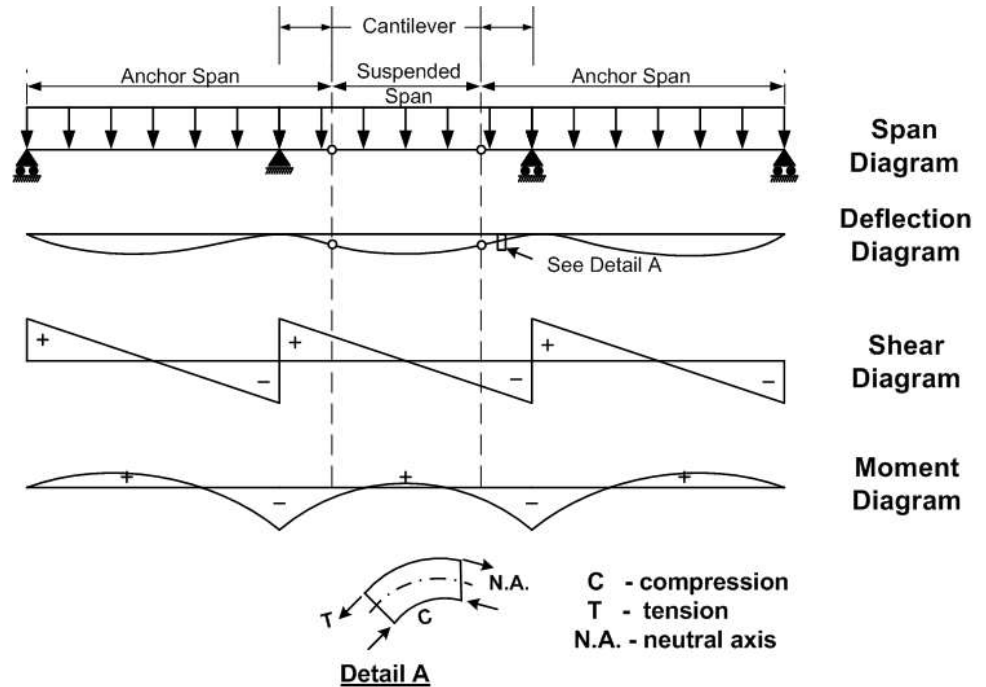


Figure 5.1.24 Cantilever Bridge

### 5.1.10 Bridge Deck Interaction

Bridges also have four classifications that are based on the relationship between the deck and the superstructure. These classifications are:

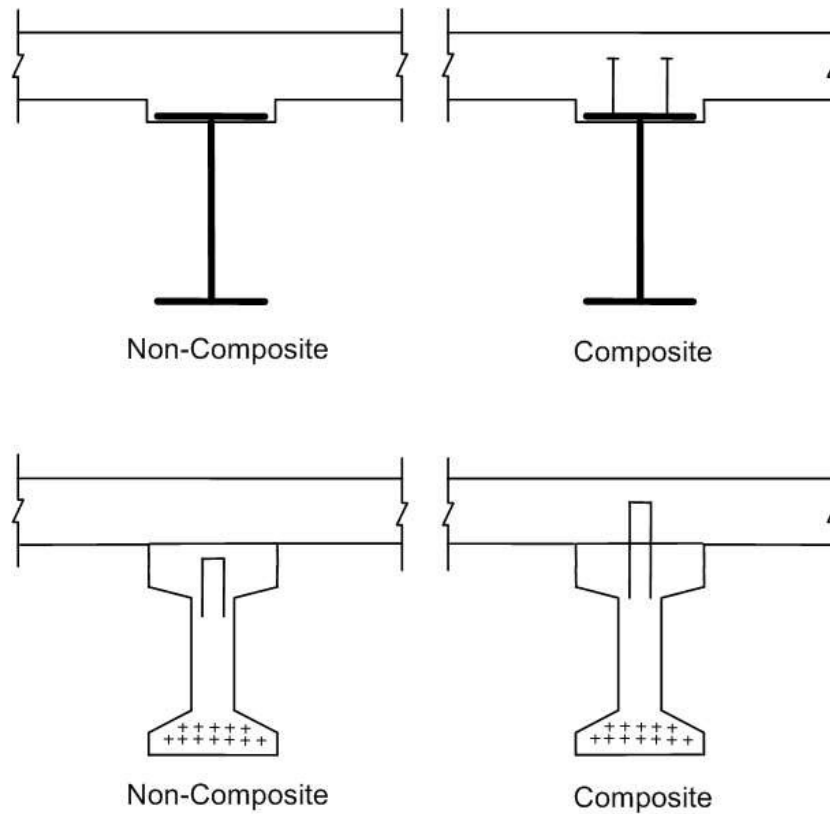
- Non-composite
- Composite
- Integral
- Orthotropic

#### Non-composite

A non-composite structure is one in which the superstructure acts independently of the deck. Therefore, the superstructure alone resists all of the loads applied to them, including the permanent loads and the transient loads.

#### Composite

A composite structure is one in which the deck acts together with the superstructure to resist the loads (see Figure 5.1.25). The deck material is strong enough to contribute significantly to the overall strength of the section. The deck material is different than the superstructure material. The most common combinations are concrete deck on steel superstructure and concrete deck on prestressed concrete superstructure. Shear connectors such as studs, spirals, channels, or stirrups that are attached to the superstructure and are embedded in a deck provide composite action. This ensures that the superstructure and the deck will act as a unit by preventing slippage between the two when a load is applied.



**Figure 5.1.25** Non-Composite or Composite Concrete Deck on Steel Beams and Prestressed Concrete Beams

Composite action is achieved only after the concrete deck has hardened. Therefore, some of the permanent load is resisted by the non-composite action of the superstructure alone. These permanent loads include the weight of:

- The superstructure itself
- Any diaphragms and cross-bracing
- The concrete deck
- Any concrete haunch between the superstructure and the deck
- Any other loads which are applied before the concrete deck has hardened

Other permanent loads, known as superimposed dead loads, are resisted by the superstructure and the concrete deck acting compositely. Superimposed dead loads include the weight of:

- Any anticipated future deck pavement
- Parapets
- Railings
- Any other loads which are applied after the concrete deck has hardened

Since live loads are applied to the bridge only after the deck has hardened, they are also resisted by the composite section.

The bridge inspector can identify a simple span, a continuous span, and a cantilever span based on their configuration. However, the bridge inspector can not identify the relationship between the deck and the superstructure while at the bridge site. Therefore, review the bridge plans to determine whether a structure is non-composite or composite.

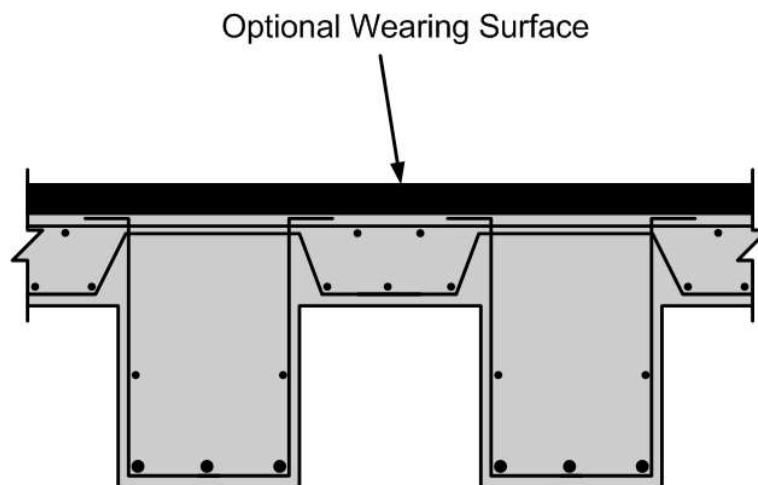
**Integral**

On an integral bridge deck, the deck portion of the beam is constructed to act integrally with the stem, providing greater stiffness and allowing increased span lengths (see Figures 5.1.26 and 5.1.27).

Integral configurations are similar to composite decks in that the deck contributes to the superstructure capacity. However, integral decks are not considered composite since the deck (or top flange) is constructed of the same material. Example of an integral bridge is a conventionally reinforced T-beam and is described in detail in Topic 9.2.



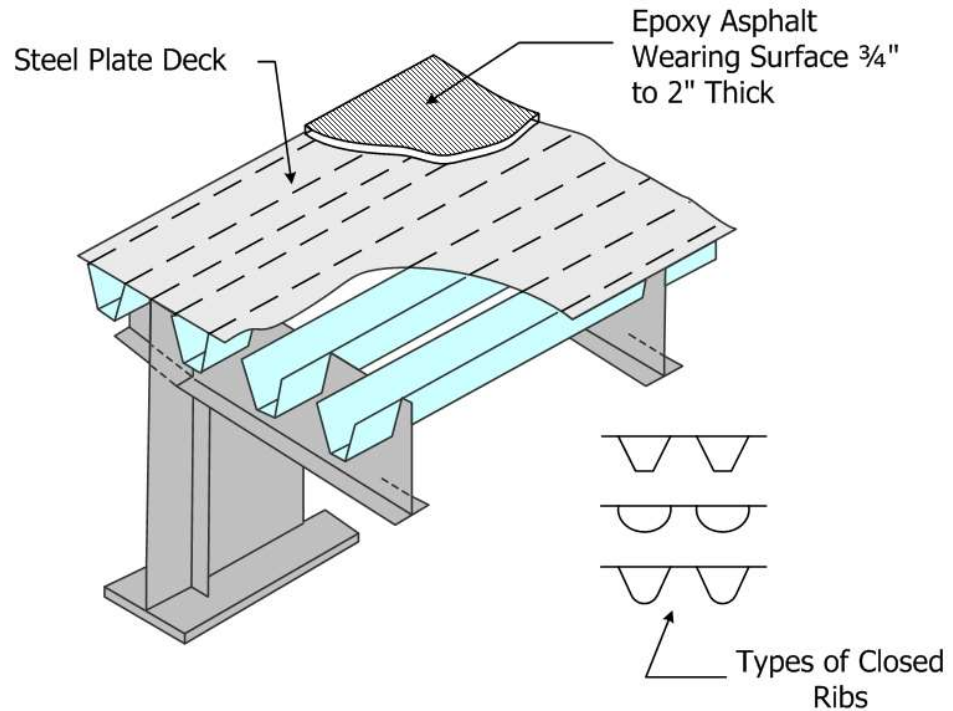
**Figure 5.1.26** Integral Bridge



**Figure 5.1.27** Cross Section of an Integral Bridge

## Orthotropic

An orthotropic deck consists of a flat, thin steel plate stiffened by a series of closely spaced longitudinal ribs at right angles to their supports. The deck acts integrally with the steel superstructure. An orthotropic deck becomes the top flange of the entire floor system. Orthotropic decks are occasionally used on large bridges (see Figure 5.1.28).



**Figure 5.1.28** Orthotropic Bridge Deck

## 5.1.11

### Redundancy

According to AASHTO Manual for Bridge Evaluation, bridge redundancy is the capability of a bridge structural system to carry loads after damage to or the failure of one or more of its members.

There are three types of redundancy in bridge design.

#### Load Path Redundancy

Bridge designs that are load path redundant have three or more main load-carrying members or load paths between supports. If one member were to fail, load would be redistributed to the other members and bridge failure would not be expected. Bridge designs that are non-redundant have two or fewer main load carrying members or load paths.

#### Structural Redundancy

Most bridge designs, which provide continuity of load path from span to span are referred to as structurally redundant. Some continuous span two-girder bridge designs are structurally redundant. In the event of a member failure, loading from that span can be redistributed to the adjacent spans and total bridge failure may not occur. A minimum of three continuous spans are needed to achieve structural redundancy in the interior spans.

### **Internal Redundancy**

Internal redundancy is when a bridge member contains three or more elements that are mechanically fastened together so that multiple independent load paths are formed. Failure of one member element would not cause total failure of the member.

### **Nonredundant Configuration**

Bridge inspectors are concerned primarily with load path redundancy and can neglect structural and internal redundancy when identifying fracture critical members. Nonredundant bridge configurations in tension contain fracture critical members. Many states currently perform 3-dimensional finite element analysis to help determine redundancy.

Redundancy is discussed in greater detail in Topic 6.4.

## **5.1.12**

---

### **Foundations**

Foundations are critical to the stability of the bridge since the foundation ultimately supports the entire structure. There are two basic types of bridge foundations:

- Shallow foundations commonly referred to as spread footings
- Deep foundations

#### **Spread Footings**

A spread footing is used when the bedrock layers are close to the ground surface or when the soil is capable of supporting the bridge. A spread footing is typically a rectangular slab made of reinforced concrete. This type of foundation "spreads out" the loads from the bridge to the underlying rock or well-compacted soil. While a spread footing is usually buried, it is generally covered with a minimal amount of soil. In cold regions, the bottom of a spread footing will be just below the recognized maximum frost line depth for that area (see Figure 5.1.29).

#### **Deep Foundations**

A deep foundation is used when the soil is not suited for supporting the bridge or when the bedrock is not close to the ground surface. A pile is a long, slender support that is typically driven into the ground but can be partially exposed. It is made from steel, concrete, or timber. Various numbers and configurations of piles can be used to support a bridge foundation. This type of foundation transfers load to sound material well below the surface or, in the case of friction piles, to the surrounding soil (see Figure 5.1.30). "Caissons", "drilled caissons", and "drilled shafts" are frequently used to transmit loads to bedrock in a manner similar to piles.

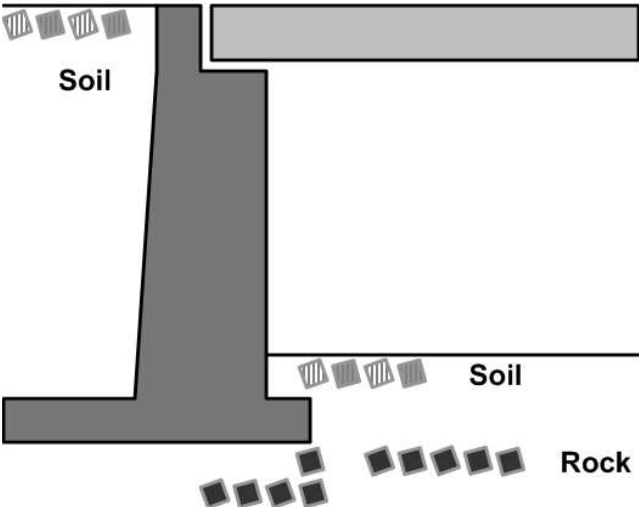


Figure 5.1.29 Spread Footing

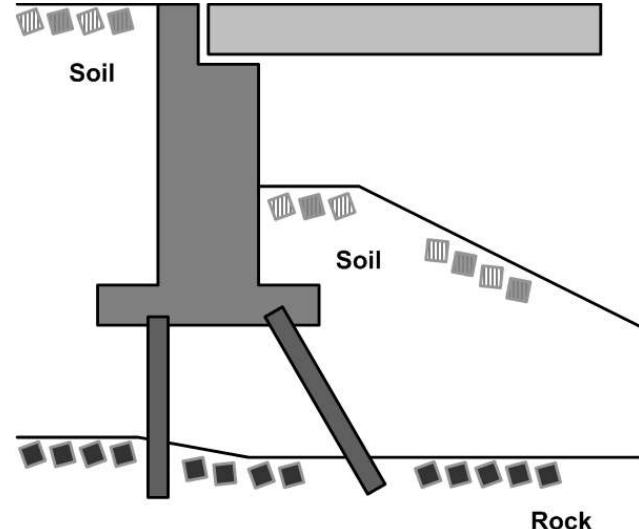


Figure 5.1.30 Deep Foundation

# Table of Contents

## Chapter 6 Bridge Materials

---

6.1	Timber .....	6.1.1
6.1.1	Introduction.....	6.1.1
6.1.2	Basic Shapes Used in Bridge Construction.....	6.1.2
	Round .....	6.1.2
	Rectangular.....	6.1.2
	Built-up Shapes .....	6.1.3
6.1.3	Properties of Timber .....	6.1.4
	Physical Properties .....	6.1.4
	Timber Classification.....	6.1.4
	Timber Anatomy .....	6.1.4
	Growth Features.....	6.1.6
	Moisture Content .....	6.1.7
	Mechanical Properties .....	6.1.7
	Orthotropic Behavior .....	6.1.7
	Fatigue Characteristics.....	6.1.7
	Impact Resistance .....	6.1.8
	Creep Characteristics .....	6.1.8
6.1.4	Timber Grading.....	6.1.8
	Sawn Lumber .....	6.1.9
	Visual Grading.....	6.1.9
	Mechanical Stress Grading .....	6.1.9
	Glued-Laminated Lumber .....	6.1.9
6.1.5	Anticipated Modes of Timber Deficiency.....	6.1.10
	Inherent Defects.....	6.1.10
	Fungi.....	6.1.11
	Insects.....	6.1.14
	Termites .....	6.1.14
	Powder-post Beetles or Lyctus Beetles.....	6.1.15
	Carpenter Ants .....	6.1.16
	Caddisflies.....	6.1.16
	Marine Borers.....	6.1.17
	Chemical Attack.....	6.1.19
	Acids .....	6.1.19
	Bases or Alkalis .....	6.1.19
	Other Types and Sources of Deterioration .....	6.1.20
	Delaminations .....	6.1.20
	Loose Connections.....	6.1.20
	Surface Depressions.....	6.1.21
	Fire.....	6.1.21
	Impact or Collisions.....	6.1.22
	Wear, Abrasion and Mechanical Wear .....	6.1.22



	Overstress.....	6.1.23
	Weathering or Warping.....	6.1.24
	Protective Coating Failure.....	6.1.25
6.1.6	Protective Systems.....	6.1.25
	Types and Characteristics of Wood Protectants.....	6.1.25
	Water Repellents.....	6.1.25
	Preservatives.....	6.1.25
	Fire Retardants.....	6.1.28
	Paint.....	6.1.28
6.1.7	Inspection Methods for Timber.....	6.1.29
	Visual Examination.....	6.1.29
	Physical Examination.....	6.1.29
	Pick or Penetration Test.....	6.1.30
	Timber Boring and Drilling Locations.....	6.1.30
	Protective Coatings.....	6.1.31
	Paint Adhesion.....	6.1.31
	Paint Dry Film Thickness.....	6.1.32
	Repainting.....	6.1.32
	Advanced Inspection Methods.....	6.1.33



**Table 4C Design Values for Mechanically Graded Dimension Lumber<sup>1,2,3</sup>**

(Tabulated design values are for normal load duration and dry service conditions, unless specified otherwise. See NDS 2.3 for a comprehensive description of design value adjustment factors.)

**USE WITH TABLE 4C ADJUSTMENT FACTORS**

Species and commercial grade	Size classification	Design values in pounds persquareinch (psi)				Grading Rules Agency		
		Bending $F_b$	Tension parallel to grain $F_t$	Compression parallel to grain $F_c$	Modulus of Elasticity $E$			
<b>MACHINE STRESS RATED (MSR) LUMBER</b>								
900F-1.0E	2" & less in thickness	900	350	1050	1,000,000	WCLIB, WWPA		
1200F-1.2E		1200	600	1400	1,200,000	NLGA, WCLIB, WWPA		
1250F-1.4E		1250	800	1475	1,400,000	WCLIB		
1350F-1.3E		1350	750	1600	1,300,000	NLGA, WCLIB, WWPA		
1400F-1.2E		1400	800	1600	1,200,000	NLGA		
1450F-1.3E		1450	800	1625	1,300,000	NLGA, WCLIB, WWPA		
1500F-1.3E		2" & wider	1500	900	1650	1,300,000	WWPA	
1500F-1.4E			1500	900	1650	1,400,000	NLGA, WCLIB, WWPA	
1600F-1.4E			1600	950	1675	1,400,000	NLGA	
1650F-1.3E			1650	1020	1700	1,300,000	NLGA, WWPA	
1650F-1.5E			1650	1020	1700	1,500,000	NLGA, SPIB, WCLIB, WWPA	
1650F-1.6E			1650	1175	1700	1,600,000	WCLIB, WWPA	
1700F-1.6E			2" & less in thickness	1700	1175	1725	1,600,000	WCLIB
1750F-2.0E				1750	1125	1725	2,000,000	WCLIB
1800F-1.5E				1800	1300	1750	1,500,000	NLGA, WWPA
1800F-1.6E				1800	1175	1750	1,600,000	NLGA, SPIB, WCLIB, WWPA
1950F-1.5E				1950	1375	1800	1,500,000	SPIB, WWPA
1950F-1.7E				1950	1375	1800	1,700,000	NLGA, SPIB, WCLIB, WWPA
2000F-1.6E		2" & wider		2000	1300	1825	1,600,000	NLGA
2100F-1.8E				2100	1575	1875	1,800,000	NLGA, SPIB, WCLIB, WWPA
2250F-1.7E				2250	1750	1925	1,700,000	NLGA, WWPA
2250F-1.8E				2250	1750	1925	1,800,000	NLGA, WCLIB, WWPA
2250F-1.9E			2250	1750	1925	1,900,000	NLGA, SPIB, WCLIB, WWPA	
2400F-1.8E			2400	1925	1975	1,800,000	NLGA, WWPA	
2400F-2.0E			2400	1925	1975	2,000,000	NLGA, SPIB, WCLIB, WWPA	
2500F-2.2E			2" & less in thickness	2500	1750	2000	2,200,000	WCLIB
2550F-2.1E				2550	2050	2025	2,100,000	NLGA, SPIB, WCLIB, WWPA
2700F-2.0E				2700	1800	2100	2,000,000	WCLIB, WWPA
2700F-2.2E		2700		2150	2100	2,200,000	NLGA, SPIB, WCLIB, WWPA	
2850F-2.3E		2850		2300	2150	2,300,000	NLGA, SPIB, WCLIB, WWPA	
3000F-2.4E	3000	2400		2200	2,400,000	NLGA, SPIB		
<b>MACHINE EVALUATED LUMBER (MEL)</b>								
M-5	2" & less in thickness	900		500	1050	1,100,000	SPIB	
M-6		1100	600	1300	1,000,000	SPIB		
M-7		1200	650	1400	1,100,000	SPIB		
M-8		1300	700	1500	1,300,000	SPIB		
M-9		1400	800	1600	1,400,000	SPIB		
M-10		1400	800	1600	1,200,000	NLGA, SPIB		
M-11		1550	850	1675	1,500,000	NLGA, SPIB		
M-12		1600	850	1675	1,600,000	NLGA, SPIB		
M-13		1600	950	1675	1,400,000	NLGA, SPIB		
M-14		1800	1000	1750	1,700,000	NLGA, SPIB		
M-15		1800	1100	1750	1,500,000	NLGA, SPIB		
M-16		1800	1300	1750	1,500,000	SPIB		
M-17 <sup>(4)</sup>		2" & wider	1950	1300	2050	1,700,000	SPIB	
M-18			2000	1200	1825	1,800,000	NLGA, SPIB	
M-19			2000	1300	1825	1,600,000	NLGA, SPIB	
M-20 <sup>(4)</sup>			2000	1600	2100	1,900,000	SPIB	
M-21			2300	1400	1950	1,900,000	NLGA, SPIB	
M-22			2350	1500	1950	1,700,000	NLGA, SPIB	
M-23			2400	1900	1975	1,800,000	NLGA, SPIB	
M-24			2700	1800	2100	1,900,000	NLGA, SPIB	
M-25			2750	2000	2100	2,200,000	NLGA, SPIB	
M-26			2800	1800	2150	2,000,000	NLGA, SPIB	
M-27 <sup>(4)</sup>		3000	2000	2400	2,100,000	SPIB		
M-28		2200	1600	1900	1,700,000	SPIB		
M-29		1550	850	1650	1,700,000	SPIB		



**Table 4D Design Values for Visually Graded Timbers (5" x 5" and larger)**

(Tabulated design values are for normal load duration and dry service conditions, unless specified otherwise. See **NDS 2.3** for a comprehensive description of design value adjustment factors.)

**USE WITH TABLE 4D ADJUSTMENT FACTORS**

Species and commercial grade	Size classification	Design values in pounds per square inch (psi)						Grading Rules Agency
		Bending $F_b$	Tension parallel to grain $F_t$	Shear parallel to grain $F_v$	Compression perpendicular to grain $F_{c\perp}$	Compression parallel to grain $F_c$	Modulus of Elasticity $E$	
<b>BALSAM FIR</b>								
Select Structural No.1	Beams and Stringers	1350	900	65	305	950	1,400,000	NELMA NSLB
No.2		1100	750	65	305	800	1,400,000	
		725	350	65	305	500	1,100,000	
Select Structural No.1	Posts and Timbers	1250	825	65	305	1000	1,400,000	
No.2		1000	675	65	305	875	1,400,000	
		575	375	65	305	400	1,100,000	
<b>BEECH-BIRCH-HICKORY</b>								
Select Structural No.1	Beams and Stringers	1650	975	90	715	975	1,500,000	NELMA
No.2		1400	700	90	715	825	1,500,000	
		900	450	90	715	525	1,200,000	
Select Structural No.1	Posts and Timbers	1550	1050	90	715	1050	1,500,000	
No.2		1250	850	90	715	900	1,500,000	
		725	475	90	715	425	1,200,000	
<b>COAST SITKA SPRUCE</b>								
Select Structural No.1	Beams and Stringers	1150	675	60	455	775	1,500,000	NLGA
No.2		950	475	60	455	650	1,500,000	
		625	325	60	455	425	1,200,000	
Select Structural No.1	Posts and Timbers	1100	725	60	455	825	1,500,000	
No.2		875	575	60	455	725	1,500,000	
		525	350	60	455	500	1,200,000	
<b>DOUGLAS FIR-LARCH</b>								
Dense Select Structural	Beams and Stringers	1900	1100	85	730	1300	1,700,000	WCLIB
Select Structural		1600	950	85	625	1100	1,600,000	
Dense No.1		1550	775	85	730	1100	1,700,000	
No.1		1350	675	85	625	925	1,600,000	
No.2		875	425	85	625	600	1,300,000	
Dense Select Structural	Posts and Timbers	1750	1150	85	730	1350	1,700,000	
Select Structural		1500	1000	85	625	1150	1,600,000	
Dense No.1		1400	950	85	730	1200	1,700,000	
No.1		1200	825	85	625	1000	1,600,000	
No.2		750	475	85	625	700	1,300,000	
Dense Select Structural	Beams and Stringers	1850	1100	85	730	1300	1,700,000	WWPA
Select Structural		1600	950	85	625	1100	1,600,000	
Dense No.1		1550	775	85	730	1100	1,700,000	
No.1		1350	675	85	625	925	1,600,000	
Dense No.2		1000	500	85	730	700	1,400,000	
No.2		875	425	85	625	600	1,300,000	
Dense Select Structural	Posts and Timbers	1750	1150	85	730	1350	1,700,000	
Select Structural		1500	1000	85	625	1150	1,600,000	
Dense No.1		1400	950	85	730	1200	1,700,000	
No.1		1200	825	85	625	1000	1,600,000	
Dense No.2		800	550	85	730	550	1,400,000	
No.2		700	475	85	625	475	1,300,000	
<b>DOUGLAS FIR-LARCH (NORTH)</b>								
Select Structural No.1	Beams and Stringers	1600	950	85	625	1100	1,600,000	NLGA
No.2		1300	675	85	625	925	1,600,000	
		875	425	85	625	600	1,300,000	
Select Structural No.1	Posts and Timbers	1500	1000	85	625	1150	1,600,000	
No.2		1200	825	85	625	1000	1,600,000	
		725	475	85	625	700	1,300,000	
<b>DOUGLAS FIR-SOUTH</b>								
Select Structural No.1	Beams and Stringers	1550	900	85	520	1000	1,200,000	WWPA
No.2		1300	625	85	520	850	1,200,000	
		825	425	85	520	525	1,000,000	
Select Structural No.1	Posts and Timbers	1400	950	85	520	1050	1,200,000	
No.2		1150	775	85	520	925	1,200,000	
		650	400	85	520	425	1,000,000	



**Table 5A Design Values for Structural Glued Laminated Softwood Timber**

(Members stressed primarily in bending) 1.2.3.4.12 (Tabulated design values are for normal load duration and dry service conditions. See NDS 2.3 for a comprehensive description of design value adjustment factors.)

Use with Table 5A Adjustment Factors

		Design values in pounds per square inch (psi)													
		BENDING ABOUT X-X AXIS (Loaded Perpendicular to Wide Faces of Laminations)					BENDING ABOUT Y-Y AXIS (Loaded Parallel to Wide Faces of Laminations)								
Combination Symbol <sup>4</sup>	Species / Outer Lams / Core Lams <sup>5</sup>	Bending		Compression Perpendicular to Grain		Shear Parallel to Grain <sup>10</sup> F <sub>vxx</sub>	Modulus of Elasticity E <sub>xx</sub>	Bending F <sub>by</sub>	Compression Perpendicular to Grain (Side Faces) F <sub>cl,y</sub>	Shear Parallel to Grain F <sub>vy</sub>	Shear Parallel to Grain (For Members With Multiple Laminations Which are Not Edge Glued) <sup>13</sup> F <sub>vy</sub>	Modulus of Elasticity E <sub>yy</sub>	Tension Parallel to Grain F <sub>t</sub>	Compression Parallel to Grain F <sub>c</sub>	Modulus of Elasticity E
		Tension Zone Stressed in Tension F <sub>tx</sub>	Compression Zone Stressed in Tension <sup>6</sup> F <sub>tx</sub>	Tension Face <sup>9,10</sup> F <sub>cl,x</sub>	Compression Face <sup>9,10</sup> F <sub>cl,x</sub>										
<b>VISUALLY GRADED WESTERN SPECIES</b>															
16F-V1	DF/MW	2000	800	560 <sup>10</sup>	560 <sup>10</sup>	140	1,300,000	950	255	130 <sup>14</sup>	65 <sup>14</sup>	1,100,000	675	975	1,100,000
16F-V2	HF/HF	1600	800	375 <sup>10</sup>	375 <sup>10</sup>	155	1,400,000	1250	375	135	70	1,300,000	875	1300	1,300,000
16F-V3	DF/DF	1600	800	560 <sup>9,10</sup>	560 <sup>9,10</sup>	190	1,500,000	1450	560	165	85	1,500,000	950	1550	1,500,000
16F-V4	DF/MW	1600	800	650	650	90 <sup>10</sup>	1,300,000	900	255	130 <sup>14</sup>	65 <sup>14</sup>	1,300,000	650	800	1,300,000
16F-V5	DF/DF	1600	800	650	650	90 <sup>10</sup>	1,600,000	1000	470	135	70	1,500,000	750	875	1,500,000
16F-V6 <sup>a</sup>	DF/DF	1600	1600	560 <sup>9,10</sup>	560 <sup>9,10</sup>	190	1,500,000	1450	560	165	85	1,400,000	950	1550	1,400,000
16F-V7 <sup>a</sup>	HF/HF	1600	1600	375 <sup>10</sup>	375 <sup>10</sup>	155	1,400,000	1200	375	135	70	1,300,000	850	1350	1,300,000
20F-V1	DF/MW	2000	1000	650	650	140	1,400,000	1000	255	130 <sup>14</sup>	65 <sup>14</sup>	1,200,000	750	1000	1,200,000
20F-V2	HF/HF	2000	1000	500 <sup>10</sup>	500 <sup>10</sup>	155	1,500,000	1200	375	135	70	1,400,000	950	1350	1,400,000
20F-V3	DF/DF	2000	1000	650	650	190	1,600,000	1450	560	165	85	1,500,000	1000	1550	1,500,000
20F-V4	DF/DF	2000	1000	590 <sup>9,10</sup>	590 <sup>9,10</sup>	190	1,600,000	1450	560	165	85	1,600,000	1000	1550	1,600,000
20F-V5	DF/MW	2000	1000	650	650	90 <sup>10</sup>	1,600,000	1000	255	135 <sup>14</sup>	70 <sup>14</sup>	1,300,000	750	725	1,300,000
20F-V7 <sup>a</sup>	DF/DF	2000	2000	650	650	190	1,600,000	1450	560	165	85	1,600,000	1000	1600	1,600,000
20F-V8 <sup>a</sup>	DF/DF	2000	2000	590 <sup>9,10</sup>	590 <sup>9,10</sup>	190	1,700,000	1450	560	165	85	1,600,000	1000	1600	1,600,000
20F-V9 <sup>a</sup>	HF/HF	2000	2000	500 <sup>10</sup>	500 <sup>10</sup>	155	1,500,000	1400	375	135	70	1,400,000	975	1400	1,400,000
20F-V12	AC/AC	2000	1000	560	560	190	1,500,000	1200	470	165	80	1,400,000	900	1500	1,400,000
22F-V1	DF/MW	2200	1100	650	650	140	1,600,000	1050	255	130 <sup>14</sup>	65 <sup>14</sup>	1,300,000	850	1100	1,300,000
22F-V3	DF/DF	2200	1100	650	650	190	1,700,000	1450	560	165	85	1,600,000	1050	1500	1,600,000
22F-V8 <sup>a</sup>	DF/DF	2200	2200	590 <sup>9,10</sup>	590 <sup>9,10</sup>	190	1,700,000	1450	560	165	85	1,600,000	1050	1650	1,600,000
22F-V10	DF/DF-S	2200	1100	650	650	190	1,600,000	1600	500	165	85	1,300,000	1000	1400	1,300,000
24F-V1	DF/MW	2400	1200	650	650	140	1,700,000	1250	255	135 <sup>14</sup>	70 <sup>14</sup>	1,400,000	1000	1300	1,400,000
24F-V2	HF/HF	2400	1200	500 <sup>10</sup>	500 <sup>10</sup>	155	1,500,000	1250	375	135	70	1,400,000	950	1300	1,400,000
24F-V4	DF/DF	2400	1200	650	650	190	1,800,000	1500	560	165	85	1,600,000	1150	1600	1,600,000
24F-V5	DF/HF	2400	1200	650	650	155	1,700,000	1350	375	140	70	1,500,000	1100	1450	1,500,000
24F-V8 <sup>a</sup>	DF/DF	2400	2400	650	650	190	1,800,000	1450	560	165	85	1,600,000	1100	1650	1,600,000
24F-V10 <sup>b</sup>	DF/DF	2400	2400	650	650	155	1,800,000	1400	375	140	70	1,600,000	1150	1600	1,600,000
24F-V11	DF/DF-S	2400	1200	650	650	190	1,700,000	1600	500	165	85	1,400,000	1150	1700	1,400,000

This page intentionally left blank.

# Chapter 6

## Bridge Materials

### Topic 6.1 Timber

#### 6.1.1

##### **Introduction**

---

Approximately 4% of the bridges listed in the National Bridge Inventory (NBI) are classified as timber bridges. Many of these bridges are very old, but the use of timber structures is gaining new popularity with the use of engineered wood products. (see Figure 6.1.1). To preserve and maintain them, it is important that the bridge inspector understand the basic characteristics of wood. Timber Bridges Design, Construction, Inspection and Maintenance April 2005 manual published by the United States Department of Agriculture, Forest Service is an excellent reference to supplement timber information in this manual and is available for purchase. For other publications from Forest Products Laboratory in PDF format, access the following link: <http://spfnic.fs.fed.us/werc/resources/PubSearch.cfm>.

For detailed information concerning the design and analysis of timber structures, contact the American Wood Council for the National Design Specifications (NDS) for Wood construction at <http://www.awc.org/standards/nds.html>. Some useful information that can be obtained to assist bridge designers and inspectors includes:

- Nominal and minimum dressed sizes of sawn lumber
- Section properties of standard dressed (S4S) sawn lumber
- Section properties of structural glued laminated timber
- Reference design values for visually graded dimension lumber
- Reference design values for mechanically graded dimension lumber
- Reference design values for visually graded decking
- Reference design values for structural glued laminated timber



**Figure 6.1.1** Glued-laminated Modern Timber Bridge

## 6.1.2

### **Basic Shapes Used in Bridge Construction**

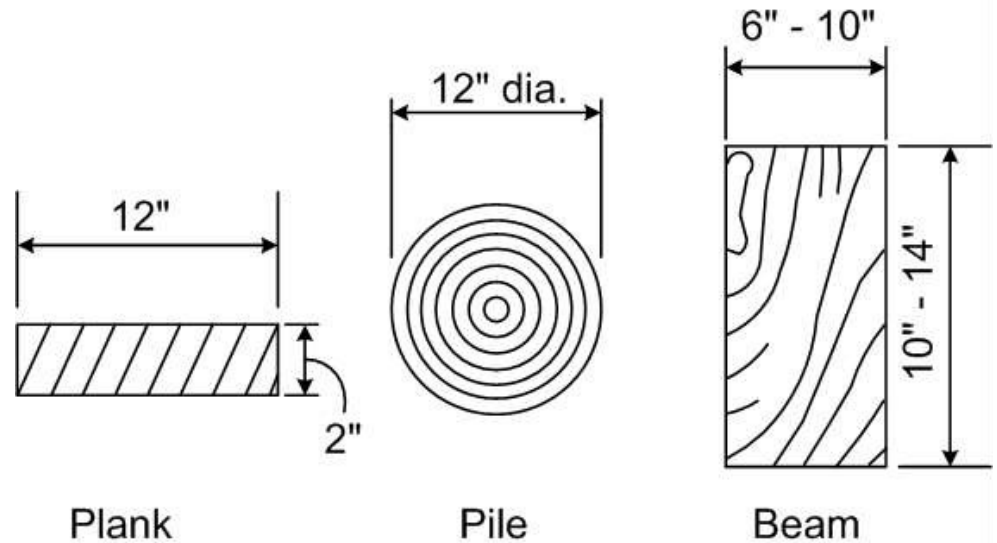
Depending on the required structural capacities and geometric constraints, wood can be cut into various shapes.

#### **Round**

Because sawmills were not created yet, most early timber bridge members were made from solid round logs. Logs were generally used as beams, or stacked and used as abutments and foundations. Round timber members have been used as piles driven into the ground or channel (See Figure 6.1.2). Logs have also been used as retaining devices for embankment material.

#### **Rectangular**

Once sawmill operations gained prominence, rectangular timber members became commonplace. Rectangular timber members were easier to connect together due to the flat sides and can be used for decking, superstructure beams, arches and truss elements, and curbs or railings (see Figure 6.1.2).

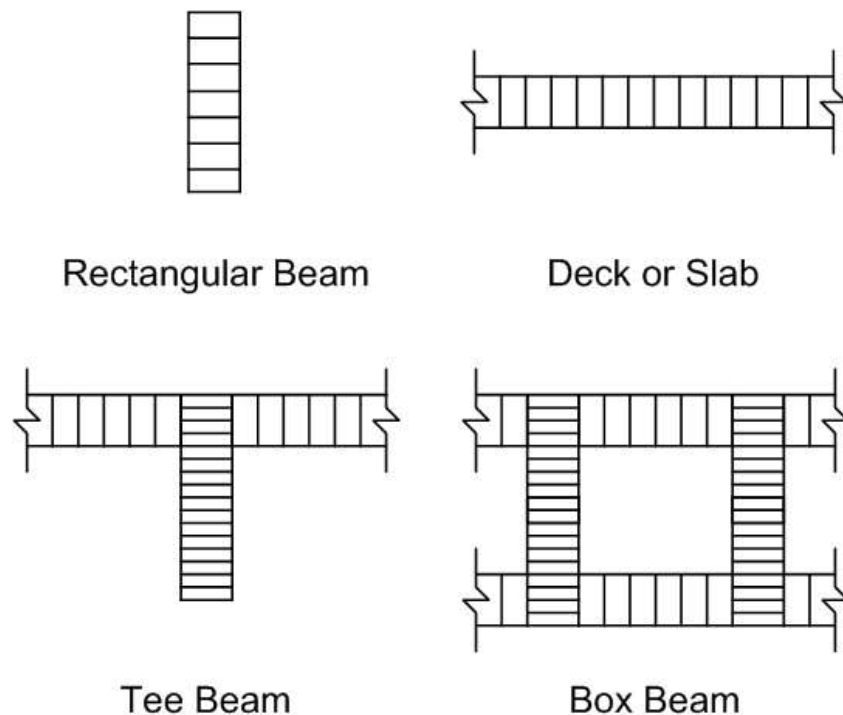


**Figure 6.1.2** Timber Shapes

**Built-up Shapes**

Modern timber bridge members are fabricated from basic rectangular shapes to create built-up shapes, which perform at high capacities. A fundamental example of these are rectangular or deck/slab beams. Two other common examples are T-shaped and box-shaped beams (see Figure 6.1.3). Using glue-laminate technology and stress timber design, these shapes enable modern timber bridges to carry current legal loads.

Refer to Chapter 8 for further information on timber superstructures and Topic 7.1 for timber decks.



**Figure 6.1.3** Built-up Timber Shapes



### 6.1.3

#### **Properties of Timber**

Because of its physical characteristics, timber is in many ways an excellent engineering material for use in bridges. Perhaps foremost is that it is a renewable resource. In addition, timber is:

- Strong, with a high strength to weight ratio
- Economical
- Aesthetically pleasing
- Readily available in many locations
- Easy to fabricate and construct
- Resistant to deicing agents
- Resistant to damage from freezing and thawing
- Able to sustain overloads for short periods of time (shock resistant)

However, timber also has some negative properties:

- Excessive creep under sustained loads
- Vulnerable to insect attack
- Vulnerable to fire

These characteristics stem from the unique physical and mechanical properties, which vary with the species and grade of the timber.

#### **Physical Properties**

There are four basic physical properties that define timber behavior. These properties are timber classification, anatomy, growth features, and moisture content.

##### **Timber Classification**

Wood may be classified as hardwood or softwood. Hardwoods have broad leaves and lose their leaves at the end of each growing season. Softwoods, or conifers, have needle-like or scale-like leaves and are evergreens. The terms "hardwood" and "softwood" are misleading because they do not necessarily indicate the hardness or softness of the wood. Some hardwoods are softer than certain softwoods and vice versa.

##### **Timber Anatomy**

Wood is a non-homogeneous material. Wood, although an extremely complex organic material, has dominant and fundamental patterns to its cell structure. Some of the physical properties of this cell structure include (see Figures 6.1.4 and 6.1.5):

- Hollow cell composition - cell walls consist of cellulose and lignin, and are formed in an oval or rectangular shape which accounts for the high strength-to-weight ratio of wood; wood with thick cell walls is dense and strong; lignin bonds the cells together

- Growth rings - revealed in the cross section of a tree are distinct rings of wood produced during a tree's growing season. One annual ring is composed of a ring of earlywood or springwood (light in color, cells have thin walls and large diameter) and a ring of latewood or summerwood (dark in color, cells have thick walls and small diameter). The rings can be easily seen in some trees (Douglas fir and southern pine) and exhibit little color difference in other species (spruces and true firs).
- Sapwood - the active, outer part of the tree that carries sap and stores food throughout the tree; is generally permeable and easier to treat with preservatives; sapwood is of lighter color than heartwood
- Heartwood - the inactive, inner part of the tree that does not carry sap; serves to support the tree; may be resistant to decay due to toxic materials deposited in the heartwood cells; usually of darker color than sapwood
- Grain - the wood fibers oriented along the long axis of logs and timbers; the direction of greatest strength
- Wood rays - groups of cells, running from the center of the tree horizontally to the bark, which are responsible for cross grain strength
- Pith - center of the tree, representing the earliest growth of the tree. The pith is more resistant to rot.
- Resin canal - tubular passageways lined with living cells producing resin or "pitch". Hardwoods do not contain resin canals.
- Bark - outer layer of a tree. The outer bark is composed of mostly dead cells that form a protective barrier for the tree. The inner bark is made from living cells which transport sugars, and may also protect the tree from contaminants.

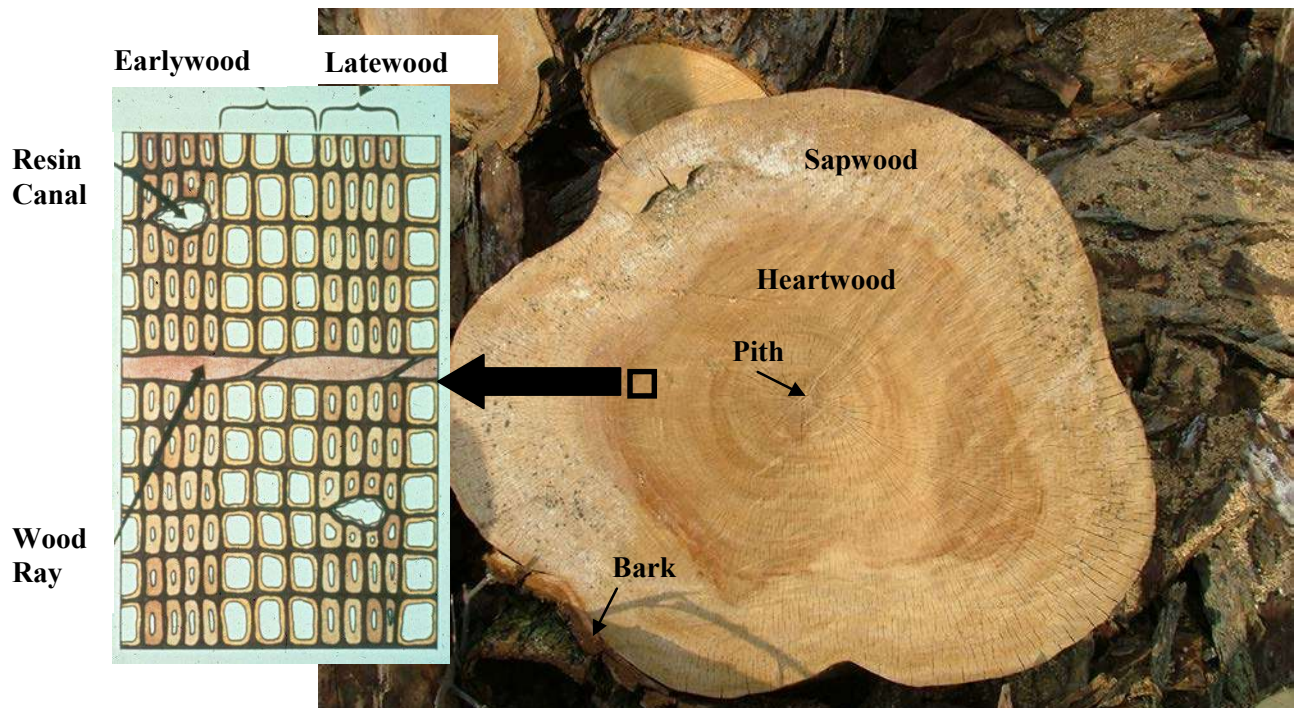
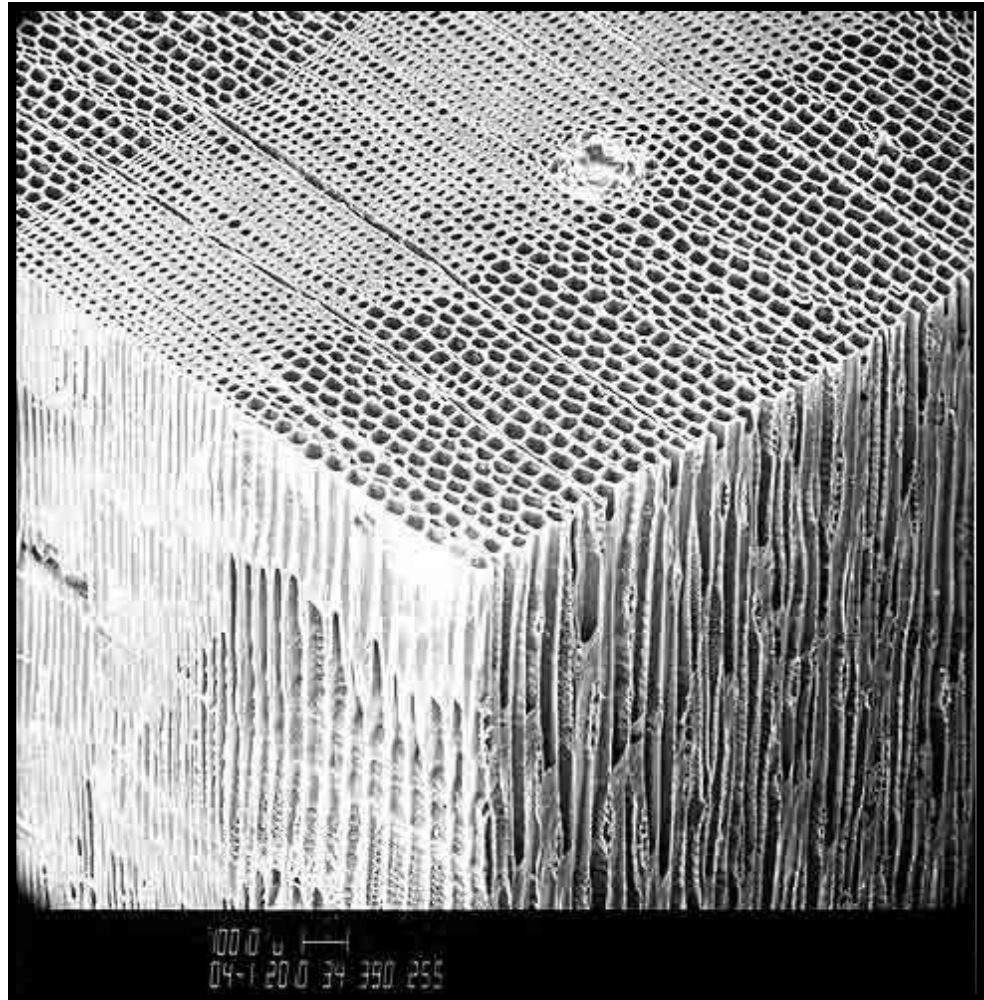


Figure 6.1.4 Anatomy of Timber



**Figure 6.1.5** 3-D Close-up of Softwood Timber Anatomy  
(Source: Society of Wood Science and Technology)

### Growth Features

A variety of growth features adversely affect the strength of wood. Some of these features include:

- Knots and knot holes - due to growth around an embedded limb and associated grain deviation. Knots may be small or large, round or elongated
- Sloping grain - caused by the normal taper of a tree or by sawing in a direction other than parallel to the grain
- Splits, checks, and shakes - separation of the cells along the grain, primarily due to rapid or uneven drying and differential shrinkage in the radial and tangential directions during seasoning; checks and splits occur across the growth rings; a shake occurs between the growth rings
- Reaction wood - a type of abnormal wood that is formed in leaning trees; the pith is off center; the wood is gelatinous and displays cross grain shrinkage checks when seasoned

### Moisture Content

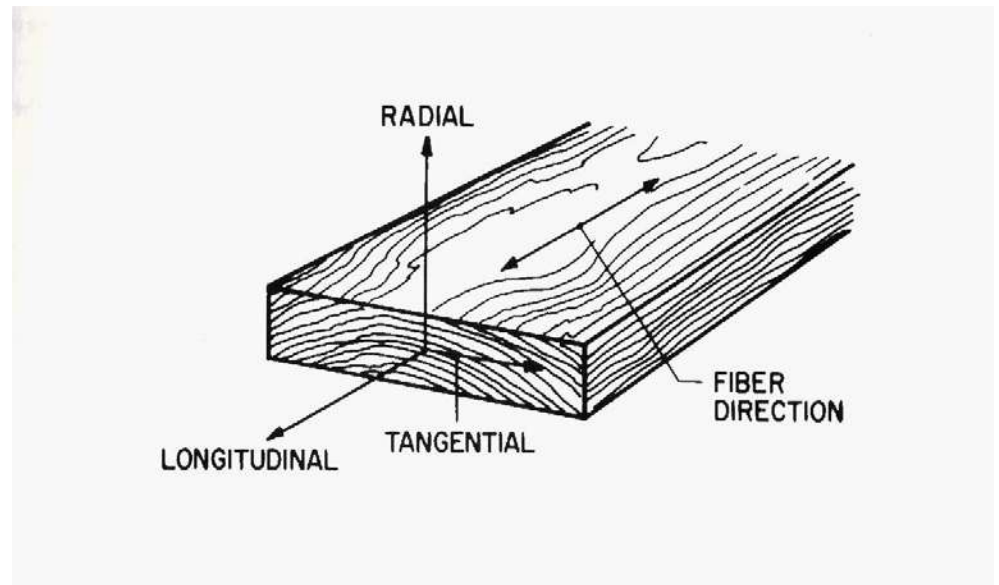
Moisture content affects dimensional instability and fluctuations of weight and affects the strength and decay resistance of wood. It is most desirable for wood to have the least moisture content as is possible. This is done naturally over time (seasoning) or using kiln drying.

### Mechanical Properties

There are four basic mechanical properties that define timber behavior: orthotropic behavior, fatigue characteristics, impact resistance and creep characteristics.

### Orthotropic Behavior

Wood is considered a non-homogeneous and an orthotropic material. It is non-homogeneous because of the random occurrences of knots, splits, checks, and the variance in cell size and shape. It is orthotropic because wood has mechanical properties that are unique or different to its three principal axes of anatomical symmetry (longitudinal, radial, and tangential). This orthotropic behavior is due to the orientation of the cell fibers in wood (see Figure 6.1.6).



**Figure 6.1.6** Three Principal Axes of Wood

As a result of its orthotropy, wood has three distinct sets of strength properties. Because timber members are longitudinal sections of wood, strength properties are commonly defined for the longitudinal axis. American Society for Testing and Materials (ASTM) Standards and American Forest and Paper Association (AF&PA) Standards are issued which present strength properties for various types of wood.

### Fatigue Characteristics

Because wood is a fibrous material, it tends to be less sensitive than steel or iron to repeated loads. Therefore, it is somewhat fatigue resistant. The presence of knots and sloping grain reduces the strength of wood considerably more than does fatigue; therefore, fatigue is generally not a limiting factor in timber design.

### **Impact Resistance**

Wood is able to sustain short-term loads of approximately twice the level it can bear on a permanent basis, provided the cumulative duration of such loads is limited.

### **Creep Characteristics**

Creep occurs when a load is maintained on the timber member. That is, the initial deflection of the member increases with time. Unseasoned or "green" timbers may sag appreciably, if allowed to season under load. Initial deflection of unseasoned wood under permanent loading can be expected to double with the passage of time. Therefore, to accommodate creep, twice the initial elastic deformation is often assumed for design. Partially seasoned material may also creep to some extent. However, thoroughly seasoned timber members will exhibit little permanent increase in deflection with time.

## **6.1.4**

### **Timber Grading**

Douglas fir and southern pines are the most widely used species of wood for bridge construction. The southern pines include several species graded and marketed under identical grading rules. Other species, such as western hemlock and eastern spruce, are suitable for bridge construction if appropriate design stresses are used. Some hardwoods are also used for bridge construction.

Timber is given a grading so that the following can be established:

- Modulus of elasticity
- Tensile stress parallel to grain
- Compressive stress parallel to grain
- Compressive stress perpendicular to grain
- Shear stress parallel to grain (horizontal shear)
- Bending stress

The ultimate strength properties of wood in the tables at the beginning of this topic are for air-dried wood, which is clear, straight grained, and free of strength-reducing deficiencies. Reduction factors need to be applied to these values based on specific application.

Timber used for outdoor applications needs to be designed for wet service conditions. This is often done with the use of a wet service reduction factor. For certain species of timber, such as Southern Pine, this factor may already be incorporated into the design strength of the wood regardless of a wet or dry service condition..

Other application-based reduction factors include temperature, member size and length, member volume, member orientation, load duration, and specific use. For more information, refer to the National Design Specifications for Wood Construction, American Forest & Paper Association, American Wood Council.

Preservative treatment for decay resistance does not alter the design strength of wood, provided any moisture associated with the treatment process is removed.

Unlike steel, the elastic modulus of wood varies with the grades and species.

## **Sawn Lumber**

The grading of sawn timber is accomplished by either a visual grading or a mechanical stress grading (MSR). Refer to the tables at the beginning of this topic.

### **Visual Grading**

This type of grading is the most common and is performed by a certified lumber grader. The lumber grader inspects each sawn and surfaced piece of lumber. The individual pieces of lumber must meet particular grade description requirements in order to be classified at a certain grade. If the requirements are not met, the piece of sawn and surfaced lumber is compared to lower grade description requirements until the piece of lumber fits into the appropriate grade. Mechanical properties are predetermined for each grade. Therefore, once the piece of lumber has been graded, the mechanical properties have been established.

### **Mechanical Stress Grading**

Mechanical stress grading or mechanical stress rating (MSR) grades lumber by the relationship between the modulus of elasticity and the bending strength of lumber. A machine measures the bending strength and then assigns an elastic modulus. The grading mainly depends on the elastic modulus but can be changed by visual observance of edge knots, checks, shakes, splits, and warps. Mechanical stress grading has a different set of grading symbols than visual grading.

## **Glued-Laminated Lumber**

Glued-laminated lumber or glulam is not graded in the same way as sawn lumber (see the tables at the beginning of this topic). Members have a combination symbol that represents the combination of lamination grades used to manufacture the member. The symbols are divided into two general classifications which are bending combinations or axial (tension or compression) combinations. The classifications are based in the anticipated use of the member, either in bending as a beam or axial combination as a column or tension member.

Bending combinations are used for resisting bending stress caused by loads applied perpendicular to the wide faces of the laminations. In this case, a lower grade lamination is used for the center portion of the member (near the neutral axis) while a higher grade lamination is placed on the outside faces where bending stresses are higher.

Axial combinations are used for resisting axial forces and bending stress applied parallel to the wide faces of the laminations. In this case, the same grade lamination is used throughout the member.

## 6.1.5

### **Anticipated Modes of Timber Deficiency**

Although timber is an excellent material for use in bridges, untreated timber is vulnerable to damage from fungi, parasites, and other sources. The untreated inner cores of surface treated timber are vulnerable to these predators if they can gain access through the outer treated shell. The degree of vulnerability varies with the species and grade of the timber. It is important for bridge inspectors to recognize the signs of the various types of damage and evaluate their effect on the structure.

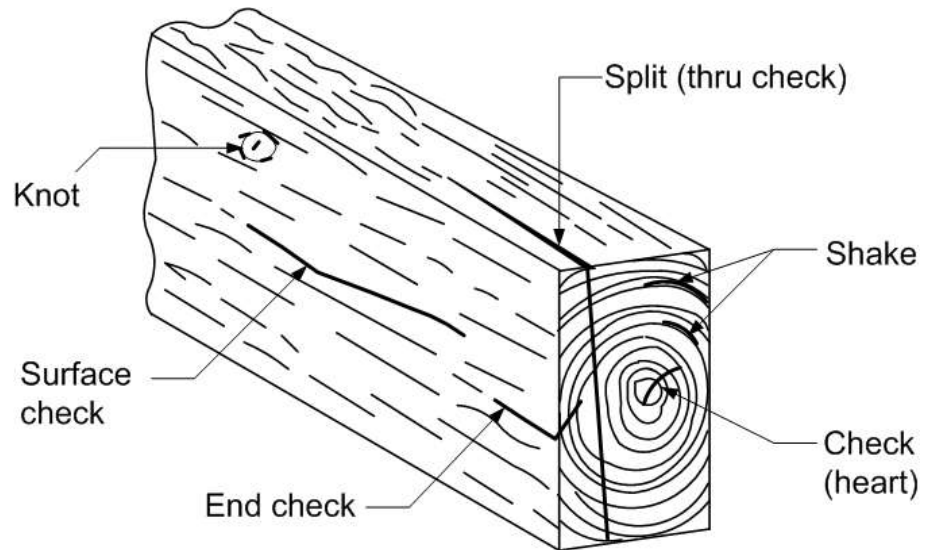
### **Inherent Defects**

Defects that form from growth features introduced in Topic 6.1.3 or from the lumber drying process include (see Figure 6.1.7):

- Checks - separations of the wood fibers, normally occurring across or through the annual growth rings, and generally parallel to the grain direction
- Splits - advanced checks that extend completely through the piece of wood. A split is also known as a through check
- Shakes - separations of the wood fibers parallel to the grain which occur between the annual growth rings
- Knots – separations of the wood fibers due to the trunk growing around an embedded limb. Knots may be small or large, round or elongated

Timber can crack, check or split due to differential shrinkage. Differential shrinkage occurs because the outer fibers in the shell dry first and begin to shrink. However, the core has not yet begun to dry and shrink, and consequently the shell is restrained from shrinking by the core. Thus the shell goes into tension and the core into compression. With the stresses from the shell and the core pulling in opposite directions the wood fibers break and a crack forms. The larger the timber member, the more stress is exerted to the timber member. This is the reason why to dry timber materials before using them where their final moisture content will be 15% or less.

These four inherent defects provide openings for decay to begin and in some cases indicate reduced strength in the member when the defect is in an advanced state.



**Figure 6.1.7** Inherent Timber Defects

## Fungi

Decay is the primary cause of timber bridge replacement. Decay is the process of living fungi, which are plants feeding on the cell walls of wood (see Figure 6.1.8). The initial process is started by the deposition of spores or microscopic seeds. Fruiting bodies (e.g., mushrooms and conks) produce these spores by the billions. The spores are distributed by wind, water, or insects.



**Figure 6.1.8** Decay of Wood by Fungi

Spores that survive and experience favorable growth conditions can penetrate timber members in a few weeks. Favorable conditions for fungi to grow can only occur when these four requirements exist:

- Oxygen - Sufficient oxygen must be available for the fungi to breathe. A minimal amount of free oxygen can sustain them in a dormant state, but at

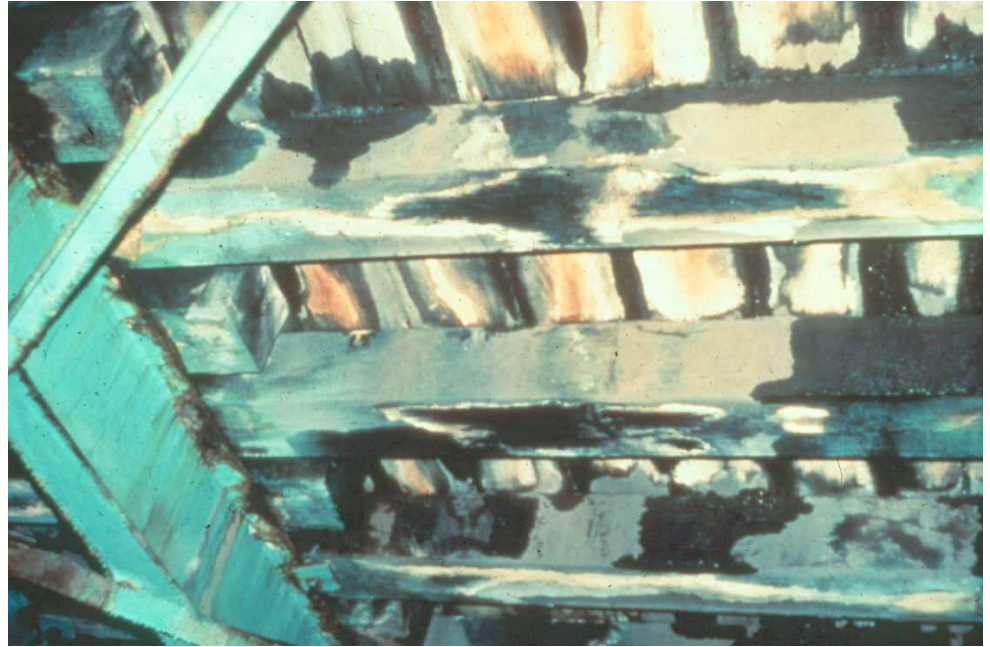


least 20 percent of the volume of wood must be occupied by air for fungi to become active. Absence of oxygen in bridge members would only occur in piling or bents placed below the permanent low water elevation or water table, or buried in the ground.

- Temperature - A favorable temperature range must be available for the growth of fungi to occur. Below freezing, 32°F, the fungi become dormant but resumes its growth as the temperature rises above freezing to the 75°F to 85°F range, where growth is at its maximum. Above 90°F, growth tapers off rapidly, and temperatures in excess of 120°F become lethal to the fungi. These killing temperatures could only occur in bridge members during kiln drying or preservative treating.
- Food - An adequate food supply must be available for the fungus to feed on. As the entire bridge serves as the food supply, the only prevention is to protect the wood supply with preservatives.
- Moisture - The fourth and probably the most controlling requirement is an adequate supply of moisture. The term "dry-rot" is misleading because dry wood will not rot. Wood must have a minimum moisture content of 20 percent to support fungi. Growth occurs when the moisture content is between 25 and 30 percent, with rapid growth of fungi above 30 percent. Rain or snow is the main source of moisture. Secondary sources are condensation, ground water, and stream water. Exposed surfaces allow moisture to evaporate harmlessly. However seasoning shakes, checks and splits, interfaces between timber members, and fastener holes are ideal for localized moisture accumulation which promotes the growth of fungi.

Although there are numerous types and species of fungi, only a few cause decay in timber bridge members. Some fungi types that do not cause damage include:

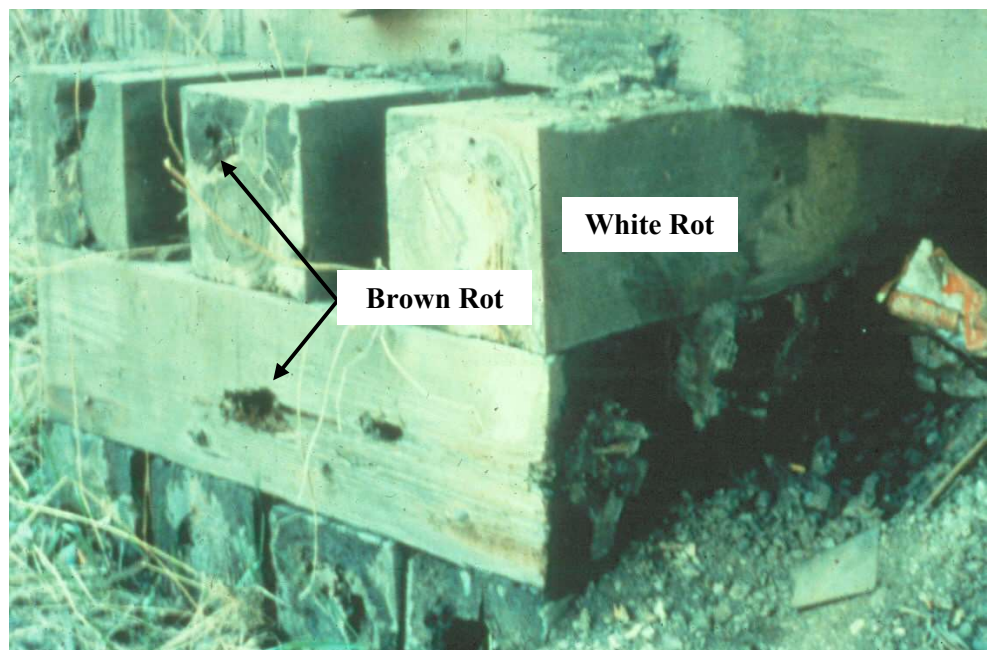
- Molds - cottony or powdery circular growths varying from white or light colors to black; molds themselves do not cause decay but their presence is an indication that conditions favorable to the growth of fungi exist (see Figure 6.1.9)
- Stains - specks, spots, streaks, or patches, varying in color, which penetrate the sap wood; sapstain is harmless to wood; it is usually a surface phenomenon and, like molds, implies conditions where harmful fungi can flourish (see Figure 6.1.9)
- Soft rot - attacks the wood, making it soft and spongy; only the surface wood is affected, and thus it does not significantly weaken the member; occurs mostly in wood of high water content and high nitrogen content



**Figure 6.1.9** Mold and Stain on Underside of Timber Bridge

Some fungi types that weaken or cause damage to timber include:

- Brown rot - degrades the cellulose and hemi-cellulose leaving the lignin as a framework which makes the wood dark brown and crumbly (see Figure 6.1.10)
- White rot - feeds upon the cellulose, hemi-cellulose, and the lignin and makes the wood white and stringy (see Figure 6.1.10).



**Figure 6.1.10** Brown and White Rot

Brown and white rots are responsible for structural damage to wood.

The natural decay resistance of wood exposed under conditions favorable for decay is distinctly variable, and it can be an important factor in the service life of timber bridges.

The heartwood of many tree species possesses a considerable degree of natural decay resistance, while the sapwood of all commercial species is vulnerable to decay.

Each year, when an inner layer or ring of sapwood dies and becomes heartwood, fungi-toxic compounds are deposited. These compounds provide natural decay resistance and are not present in living sapwood.

Most existing timber bridges in this country have been constructed from either Douglas fir or southern pine. Older bridges may contain such additional species as larch, various pines, and red oak. The above named species are classified as moderately decay resistant. Western red cedar and white oak are considered very decay resistant.

In the last 40 years, bridge materials have been obtained increasingly from smaller trees in young-growth timber stands. As a result, recent supplies of lumber and timbers have contained increased percentages of decay-susceptible sapwood.

## **Insects**

Insects tunnel in and hollow out the insides of timber members for food or shelter. Common types of insects that damage bridges include:

- Termites
- Powder-post beetles or lyctus beetles
- Carpenter ants
- Caddisflies

### **Termites**

Termites are pale-colored, soft-bodied insects that feed on wood (see Figure 6.1.11). All damage is inside the surface of the wood; hence, it is not visible. The only visible signs of infestation are white mud shelter tubes or runways extending up from the earth to the wood and on the sides of masonry substructures. Termite attack of bridge members, however, is rare in bridges throughout most of the country due to the constant vibration caused by traffic travelling over timber bridges.



**Figure 6.1.11** Termites

#### **Powder-post Beetles or Lyctus Beetles**

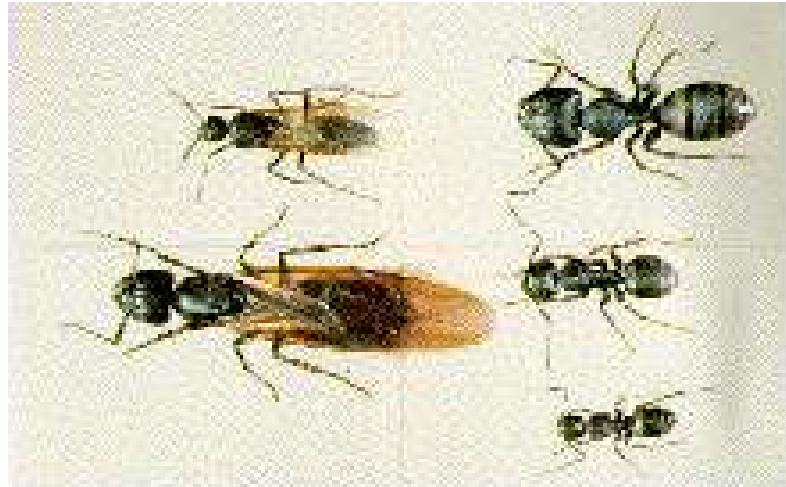
Powder-post beetles (see Figure 6.1.12) also hollow out the insides of timber members and leave the outer surface pocked with small holes. Often a powdery dust is dislodged from the holes. The inside may be completely excavated as the larvae of these beetles bore through the wood for food and shelter.



**Figure 6.1.12** Powder Post Beetle

### Carpenter Ants

Carpenter ants are large, black ants up to 3/4 inches long that gnaw galleries in soft or decayed wood (see Figure 6.1.13). The ants may be seen in the vicinity of the infested wood, but the accumulation of sawdust on the ground at the base of the timber is also an indicator of their presence. The ants do not use the wood for food but build their galleries in the moist and soft or partially decayed wood.



**Figure 6.1.13** Carpenter Ants

### Caddisflies

The caddisfly is another insect that can damage timber piles. It is generally found in fresh water but can also be found in brackish water. Bacterial and fungal decay make the timber attractive to the caddisfly.

The caddisfly is an aquatic insect that is closely related to the moth and butterfly (see Figure 6.1.14). During the larva and pupa stage of their life cycle, they can dig small holes in the timber for protection. The larvae do not feed on the timber, but rather use it as a foundation for their shelters. This explains why caddisfly larvae have been known to exist on creosote treated timber.



**Figure 6.1.14** Caddisfly Larva

### **Marine Borers**

Marine borers are found in sea water and brackish water only and cause severe damage to timber members in the area between high and low water, although damage may extend to the mud line (see Figure 6.1.15). They can be very destructive to wood and have been known to consume piles and framing in just a few months.

One type of marine borer is the mollusk borer, or shipworm (see Figure 6.1.16). The shipworm is one of the most serious enemies of marine timber installations. The teredo is the most common species of shipworm. This shipworm enters the timber in an early stage of life and remains there for the rest of its life. Teredos are gray and slimy and can typically reach a length of 15 inches and a diameter of  $\frac{3}{8}$  inch. Some species of shipworm have been known to grow to a length of 6 feet and up to 1 inch in diameter. The teredo maintains a small opening in the surface of the wood to obtain nourishment from the sea water.



**Figure 6.1.15** Marine Borer Damage to Wood Piling



**Figure 6.1.16** Shipworm (Mollusk)

Another type of marine borer is the crustacean borer. The most commonly encountered crustacean borer is the limnoria or wood louse (see Figure 6.1.17). It bores into the surface of the wood to a shallow depth. Wave action or floating debris breaks down the thin shell of timber outside the borers' burrows, causing the limnoria to burrow deeper. The continuous burrowing results in a progressive deterioration of the timber pile cross section, which will be noticeable by an hourglass shape developed between the tide levels. These borers are about 1/8 to 1/4 inches long and 1/16 to 1/8 inches wide.



**Figure 6.1.17** Limnoria (Wood Louse)

### **Chemical Attack**

Most petroleum based products and chemicals do not cause structural degradation to wood. However, animal waste can cause some damage, and strong alkalis will destroy wood fairly rapidly. Highway bridges are seldom exposed to these substances. Timber structures normally do not come in contact with damaging chemicals unless an accidental spill occurs.

#### **Acids**

Wood resists the effects of certain acids better than many materials and is often used for acid storage tanks. However, strong acids that have oxidizing properties, such as sulphuric and sulphurous acid, are able to slowly remove a timber structure's fiber by attacking the cellulose and hemi-cellulose. Acid damaged wood has weight and strength losses and looks as if it has been burned by fire.

#### **Bases or Alkalis**

Strong bases or alkalis attack and weaken the hemi-cellulose and lignin in the timber structure. Attack by strong bases leaves the wood a bleached white color. Mild alkalis do little harm to wood.



**Other Types and Sources of Deterioration**    **Delaminations**

Delaminations occur in glued-laminated members when the layers separate due to failure within the adhesive or at the bond between the adhesive and the laminate. They provide openings for decay to begin and may cause a reduction in strength (see Figure 6.1.18).



**Figure 6.1.18** Delamination in a Glue Laminated Timber Member

**Loose connections**

Loose connections may be due to shrinkage of the wood, crushing of the wood around the fastener, or from repetitive impact loading (working) of the connection. Loose connections can reduce the bridge's load-carrying capacity (see Figure 6.1.19).



**Figure 6.1.19** Loose Hanger Connection Between the Timber Truss and Floorbeam

### Surface depressions

Surface depressions indicate internal collapse, which could be caused by decay.

### Fire

Fire consumes wood at a rate of about 0.05 inches per minute during the first 30 minutes of exposure, and 0.021 inches per minute thereafter (see Figure 6.1.20). Large timbers build a protective coating of char (carbon) after the first 30 minutes of exposure. Small size timbers do not have enough volume to do this before they are, for all practical purposes, consumed by fire. Preservative treatments are available to retard fire damage.



**Figure 6.1.20** Fire Damaged Timber Members

### Impact or Collisions

Severe damage can occur to truss members, railings, and columns when an errant vehicle strikes them (see Figure 6.1.21).



**Figure 6.1.21** Impact/Collision Damage to a Timber Member

### Wear, Abrasion and Mechanical Wear

Vehicular traffic is the main source of wear on timber decks (see Figure 6.1.22). Abrasion occurs on timber piles that are subjected to tidal flows. Mechanical wear of timber members sometimes occurs due to movement of the fasteners against their holes when connections become loose.



**Figure 6.1.22** Wear of a Timber Deck

### Overstress

Each timber member has a certain ultimate load capacity. If this load capacity is exceeded, the member will fail. Failure modes include horizontal shear failure, bending moment or flexural failure, and crushing (see Figures 6.1.23, 6.1.24, and 6.1.25).



**Figure 6.1.23** Horizontal Shear Failure in Timber Member



**Figure 6.1.24** Failed Timber Floorbeam due to Excessive Bending Moment



**Figure 6.1.25** Timber Substructure Member Subjected to Crushing and Overstress

### **Weathering or Warping**

Weathering is the affect of sunlight, water, and heat. Weathering can change the equilibrium moisture content in the wood in a non-uniform fashion, thereby resulting in changes in the strength and dimensions of the wood. Uneven reduction in moisture content causes localized shrinkage, which can lead to warping, checking, splitting, or loosening of connectors (see Figure 6.1.26).



**Figure 6.1.26** Weathering on Timber Deck

### **Protective Coating Failure**

The following paint failures are common on timber structures:

- Cracking and peeling extend with the grain of the wood. They are caused by different shrinkage and swell rates of expansion and contraction between springwood and denser summerwood.
- Decay fungi penetrate through cracks in the paint to cause wood to decay.
- Blistering is caused by paint applied over an improperly cleaned surface. Water, oil, or grease typically are responsible for blistering.
- Chalking is a degradation of the paint, usually by the ultraviolet rays of sunlight, leaving a powdery residue.
- Erosion is general thinning of the paint due to chalking, weathering, or abrasion.
- Mold fungi and stain fungi grow on the surface of paint, usually in warm, humid, shaded areas with low air flow. They appear as small green or black spots.

## **6.1.6**

### **Protective Systems**

Protective systems are a necessity when using timber for bridge construction. Proper preparation of the timber surface is required for the protective system to penetrate the wood surface and perform adequately.

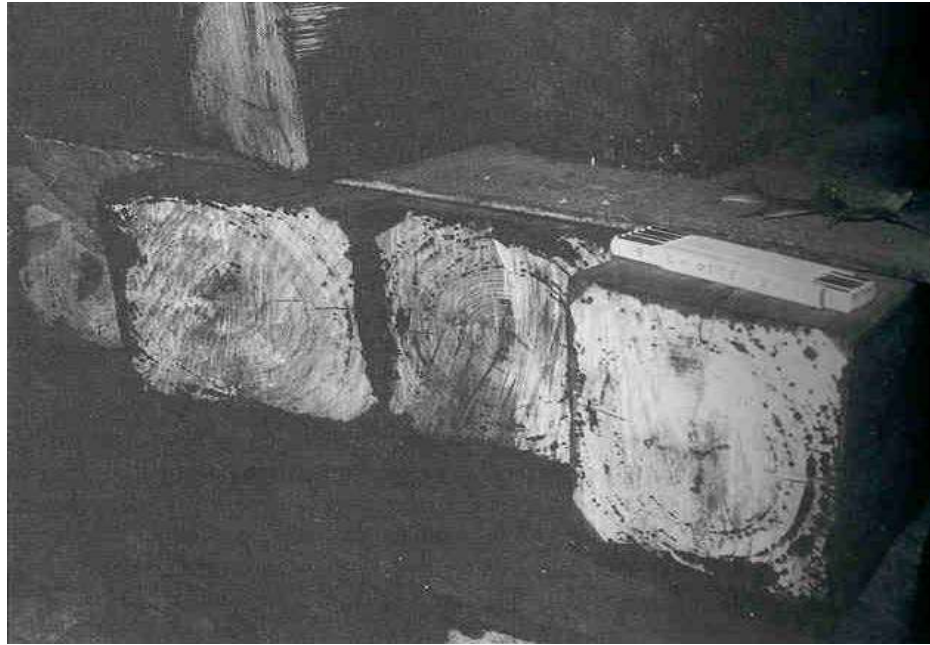
### **Types and Characteristics of Wood Protectants**

#### **Water Repellents**

Water repellents slow or retard water absorption and maintain low moisture content in wood. This helps to prevent decay by molds and to slow the weathering process. Laminated wood (plywood) is particularly susceptible to moisture variations, which cause stress between layers due to swelling and shrinkage.

#### **Preservatives**

Wood preservatives prevent biological deterioration that can penetrate into timber. To be effective, the preservatives have to be applied to wood by vacuum-pressure treatment. This is done by placing the timber to be treated in a sealed chamber up to 8 feet in diameter and 140 feet long. The chamber is placed under a vacuum, drawing the air from the wood pores and cells. The treatment chemical is then fed into the chamber and pressure up to 200 psi is applied, forcing the chemical into the wood (see Figure 6.1.27). Preservatives are the best means to prevent decay but do not prevent weathering. A paint or water repellent coating is required for this. Treated timber generally has a unit weight of about 50 pounds per cubic foot (pcf) compared to approximately 40-45 pcf for untreated timber.



**Figure 6.1.27** Bridge Timber Member Showing Penetration Depth of Preservative Treatment

Coal tar-cresote is a dark, oily protectant used in structural timber such as pilings and beams. Coal tar-cresote treated timber has a dark, oily appearance (see Figure 6.1.28). Unless it has weathered for several years, it cannot be painted, since paint adheres poorly to the oily surface, and the oils bleed through paint. Due to environmental and health concerns, new bridge construction practices do not allow the use of creosote.



**Figure 6.1.28** Coal-Tar Creosote Treated Timber Beams (Source: Barry Dickson, West Virginia University)

Pentachlorophenol (in a light oil solvent) is an organic solvent solution used as an above-ground decay inhibitor. It also leaves an oily surface, like creosote, but can be painted after all of the solvent has evaporated, usually in one or two years of normal service, though this practice is not usually recommended.

Copper naphthenate is an organic solvent solution suitable for above-ground, ground contact, or freshwater applications. It is not standardized for salt water uses. When applied, copper naphthenate stains the wood to a light green color which weathers to a light brown. It leaves an oily surface and should not be used for frequent human contact. Timber members treated with this preservative may be painted several weeks after weathering. Cuts or holes may be treated in the field with copper naphthenate.

Oxine copper is an organometallic compound that is used for above-ground applications (when dissolved in a heavy oil). Examples include difficult-to-treat species such as Douglas-fir for bridges and railings. The effectiveness of oxine copper is significantly reduced when used in direct contact with ground or water, and has therefore not been standardized for those applications. Oxine copper is also used to pressure-treat wood and may be used to control fungi and insects.

Chromated copper arsenate (CCA) was the most popular timber preservative from the late 1970's until 2004. CCA is an excellent waterborne salt decay inhibitor, but can also be used for above-ground, ground contact, and freshwater applications. CCA is applied by vacuum-pressure treatment and comes in three standard formulations: CCA Type A, CCA Type B, and CCA Type C (most common). Timber treated with CCA has a green appearance, but readily accepts painting. CCA also provides limited protection against the ultraviolet rays in sunlight. This compound has been voluntarily phased out for residential and other human contact applications and is restricted by the EPA.

Ammoniacal copper zinc arsenate (ACZA) is a refined variant of ammoniacal copper arsenate (ACA), which is no longer available in the United States. The color of ACZA treated wood ranges from olive to bluish green and has a slight ammonia odor until it has cured. This preservative is effective against fungi and insect attack over a wide range of exposures and applications, including ground and water contact. Despite accelerating fastener corrosion, many agencies require treatment with ACZA for highway structures and other critical structural components. This preservative is especially common in the Western United States.

Alkaline copper quaternary (ACQ) compounds have recently been developed and marketed in response to the rapidly declining use of CCA, despite the inability to be used in saltwater environments. Similar to CCA, ACQ has several different variations including ACQ Type B, ACQ Type C, and ACQ Type D. Treatment with ACQ-B is used for difficult-to-treat Western species, as this compound is more effective than other waterborne preservatives. ACQ-B gives off a dark greenish-brown color which later fades to a lighter brown. Treatment with ACQ-D is used for most other easy-to-treat applications, especially for pressure-treated lumber. ACQ-D gives off a lighter greenish-brown color. Applications for ACQ-C are still limited, as this variant is the most recently standardized. Overall, ACQ compounds have proven effective against fungi and insects for ground contact applications. Similar to treatment with ACZA, ACQ compounds accelerate



corrosion of metal fasteners.

Copper azole is another recently developed compound marketed as an alternative to CCA. This chemical is designed to protect wood from decay and insect attack and comes in two different formulations, copper azole type A (CBA-A) and copper azole type B (CA-B). With CBA-A no longer used in the United States, CA-B is also frequently used for pressure-treated applications along with ACQ-D. For difficult-to-treat Western species, ammonia may be added to CA-B, though this addition darkens the otherwise greenish-brown color. As with ACZA and ACQ compounds, copper azole formulations increase corrosion rates of metal fasteners. Copper azole compounds cannot be used for saltwater applications.

### **Fire Retardants**

Fire retardants will not indefinitely prevent wood from burning but will slow or retard the spread of fire and prolong the time to ignite wood. The two main classes of fire retardants are pressure impregnated fire retardant salts and intumescent coatings (paints). The intumescent paints expand upon intense heat exposure, forming a thick, puffy, charred coating which insulates the wood from the intense heat. Application of fire retardants may change some wood properties of glued-laminated timber.

### **Paint**

Wood must be sufficiently dry to permit painting. A few months of seasoning will satisfactorily dry new wood enough to paint. The wood surface must be free of dirt and debris prior to painting. Old, poorly adherent paint must be removed and the edges of intact paint feathered for a smooth finish. Mildew shows up as green or black spots on bare wood or paint. It is a fungus which typically grows in warm, humid, shaded areas with low air movement. In order for paint to adhere, mildew is removed with a solution of sodium hypochlorite (bleach) and water.

There are several common methods to prepare wood for painting:

- Hand tool cleaning is the simplest but slowest method. Sandpaper, scrapers, and wire brushes are used to clean small areas.
- Power tool cleaning utilizes powerized versions of the hand tools. They are faster than hand tools, but care must be exercised not to damage the wood substrate.
- Heat application with an electric heat gun softens old paint for easier removal to bare wood.
- Solvent-based and caustic chemical paint removers can efficiently clean large areas quickly. Some of the chemicals may, however, present serious fire or exposure hazards. Extreme caution must be exercised when working around chemical paint removers.
- Open nozzle abrasive blast cleaning and water blast cleaning remove old paint and foreign material, leaving bare wood. However, they can easily damage wood unless used carefully.

Paint protects wood from both moisture and weathering. By precluding moisture

from wood, paint prevents decay. However, paint applied over unseasoned wood seals in moisture, accelerating, rather than retarding, decay. Oil-based paint and latex paint are both commonly used on wood bridges.

Oil-based paint provides the best shield from moisture. It is not, however, the most durable. It does not expand and contract as well as latex, and it is more prone to cracking. Oil/alkyd paints cure by air oxidation. These paints are low cost, with good durability, flexibility, and gloss retention. They are resistant to heat and solvents. Alkyd paints often contain lead pigments, known to cause numerous health hazards. The removal and disposal of lead paint is a regulated activity in all states.

Latex paint consists of a latex emulsion in water. Latex paint is often referred to as water-based paint. There are many types of latex paint, each formulated for a different application. They have excellent flexibility and color retention, with good adhesion, hardness, and resistance to chemicals.

### 6.1.7

#### **Inspection Methods for Timber**

There are three basic methods used to inspect a timber member. Depending on the type of inspection, the inspector may be required to use only one individual method or all methods. They include:

- Visual
- Physical
- Advanced inspection methods

#### **Visual Examination**

There are two types of visual inspections that may be required of an inspector. The first, called a routine inspection, involves reviewing the previous inspection report and visually examining the members from beneath the bridge. A routine inspection involves a visual assessment to identify obvious deficiencies.

The second type of visual inspection is called an in-depth inspection. An in-depth inspection is an inspection of one or more members above or below the water level to identify any deficiencies not readily detectable using routine methods. Hands-in inspection may be necessary at some locations. This type of visual inspection requires the inspector to visually assess all defective timber surfaces at a distance no further than an arm's length. The timber surfaces are given close visual attention to quantify and qualify any deficiencies. The hands-on inspection method may be supplemented by nondestructive testing.

For timber members, visual inspections reveal areas that need further investigation such as checks, splits, shakes, fungus decay, deflection, or loose fasteners.

#### **Physical Examination**

Once the deficiencies are identified visually, physical methods must be used to verify the extent of the deficiency. Most physical inspection methods for timber members involve destructive methods. An inspection hammer, on the other hand, does not damage timber and can be used to tap on areas and determine the extent of internal decay. This is done by listening to the sound the hammer makes. If it sounds hollow, internal decay may be present.

Sounding the wood surface by striking it with a hammer or other object is one of the oldest and most commonly used inspection methods for detecting interior deterioration. Based on the tonal quality of the ensuing sounds, a trained inspector can interpret dull or hollow sounds that may indicate the presence of large interior voids or decay. Although sounding is widely used, it is often difficult to interpret because factors other than decay can contribute to variations in sound quality. In addition, because sounding will reveal only serious internal deficiencies, it is never to be the only method used. Sounding provides only a partial picture of the extent of decay present and will not detect wood in the incipient or intermediate stages of decay. Nevertheless, sounding still has its place in inspection and can quickly identify seriously decayed structures. When suspected decay is encountered, it must be verified by other methods such as boring or coring.

Some methods or areas of physical examination include:

### **Pick or Penetration Test**

A pick or penetration test involves lifting a small sliver of wood with a pick or pocketknife and observing whether or not it splinters or breaks abruptly (see Figure 6.1.29). Sound wood splinters, while decayed wood breaks abruptly.



**Figure 6.1.29** Inspector Performing a Pick Test

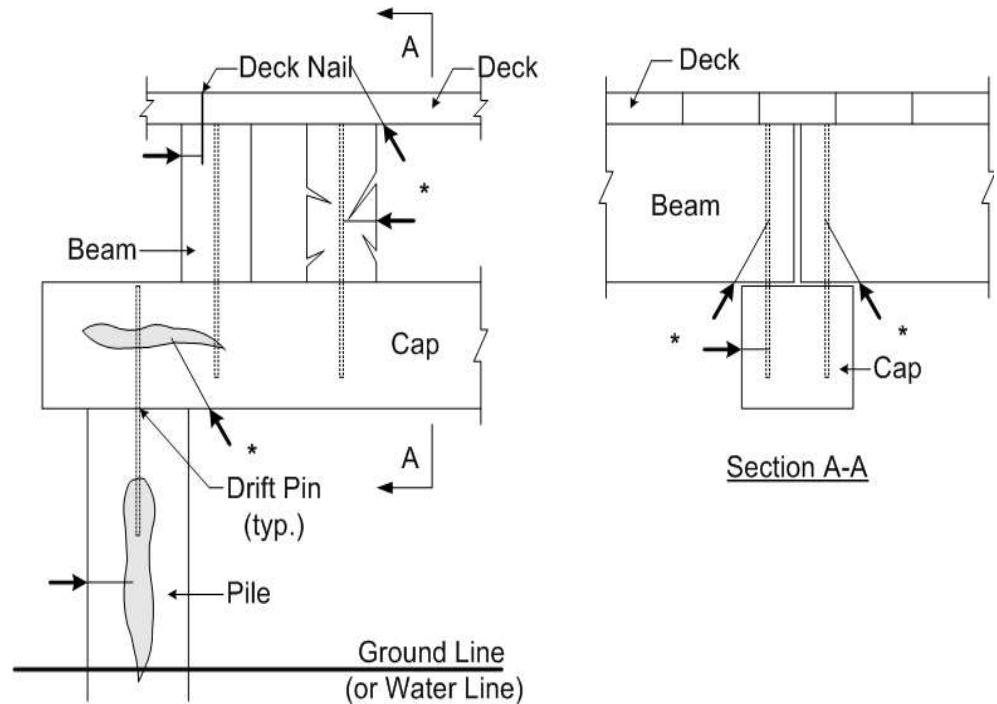
### **Timber Boring and Drilling Locations**

The following are common timber boring and drilling locations (see Figure 6.1.30):

- Deck planks - in the bottom, next to a beam.
- Beams - in sides near the deck and in the bottom over the bent cap.
- Cap - under the beams and over posts and piles.
- Post/pile - top under cap and bottom just above ground or water line.

These locations are suspect areas where moisture accumulates and could lead to decay.

An inspector may be required to take samples to determine the condition of the wood. When drilling or boring vertical faces, always drill at a slight upward angle so that any drainage will flow away from the plugged hole. Apply repairs to any drilled holes once the drilling and boring is complete.



**Figure 6.1.30** Timber Boring and Drilling Locations

### Protective Coatings

When inspecting timber bridges, keep in mind the environment surrounding the bridge and how this can cause failures leading to rapid decay of the underlying wood members. Check the condition of the protective coatings.

### Paint Adhesion

Probe the paint with the point of a knife to test paint adhesion to wood. Attempt to lift the paint. Adhesion failure may occur between wood and paint or between layers of paint.

Another paint adhesion assessment method is performed in accordance with American Society for Testing and Materials (ASTM) D-3359 "Measuring Adhesion by Tape Test" which is used primarily for metal substrates. An "X" is cut through the paint to the wood surface. Adhesive test tape is applied over the "X" and removed in a continuous motion. The amount of paint (if any) removed is noted. Adhesion is rated on a scale of 0 to 5. Refer to ASTM D-3359 for the rating criteria.

### Paint Dry Film Thickness

Paint dry film thickness can be directly measured with a special gage (see Figure 6.1.31). With this instrument, a groove is cut at a known angle with the grain through the paint to expose the wood substrate. The thickness of each layer of paint is measured through a 50-power microscope built into the gage.



**Figure 6.1.31** Gage Used to Measure Coating Dry Film Thickness

### Repainting

If the coating is to be repainted, the type of paint in the existing topcoat must be known, since paints of different type may not adhere well to each other. Two methods to determine the type of existing paint are:

- Check historical records of previous painting
- Obtain paint samples from the bridge for laboratory analysis

Alternately, a test patch may be coated with new paint over intact existing paint. After the paint thoroughly dries in accordance with the manufacturer's specification, inspect the appearance and adhesion of the new paint.

**Advanced Inspection  
Methods**

In addition, several advanced methods are available for timber inspection. Nondestructive methods, described in Topic 15.1.1, include:

- Sonic testing
- Spectral analysis
- Ultrasonic testing
- Vibration

Other methods, described in Topic 15.1.3, include:

- Boring or drilling
- Moisture content
- Probing
- Field Ohmmeter

This page intentionally left blank

# Table of Contents

## Chapter 6 Bridge Materials

---

6.2	Concrete .....	6.2.1
6.2.1	Introduction.....	6.2.1
	Portland Cement.....	6.2.1
	Water .....	6.2.1
	Air .....	6.2.2
	Aggregates.....	6.2.2
	Admixtures.....	6.2.2
6.2.2	Basic Shapes Used in Bridge Construction.....	6.2.4
	Round .....	6.2.4
	Rectangular.....	6.2.4
6.2.3	Properties of Concrete.....	6.2.5
	Physical Properties .....	6.2.5
	Mechanical Properties .....	6.2.5
	High Performance Concrete .....	6.2.6
	Ultra-High Performance Concrete.....	6.2.7
6.2.4	Reinforced Concrete .....	6.2.7
	Conventionally Reinforced Concrete .....	6.2.7
	Fiber Reinforced Polymer Applications .....	6.2.11
6.2.5	Prestressed Concrete .....	6.2.11
	Prestressing Methods.....	6.2.12
	Prestressing Reinforcement .....	6.2.13
6.2.6	Anticipated Modes of Concrete Deficiencies .....	6.2.15
	Cracks.....	6.2.15
	Flexure Cracks .....	6.2.16
	Shear Cracks .....	6.2.16
	Crack Size .....	6.2.18
	Nonstructural Cracks .....	6.2.19
	Crack Orientation.....	6.2.21
	Scaling .....	6.2.23
	Delamination .....	6.2.25
	Spalling.....	6.2.25
	Chloride Contamination .....	6.2.26
	Freeze-Thaw .....	6.2.26
	Efflorescence .....	6.2.27
	Alkali-Silica Reaction .....	6.2.28
	Ettringite Formation .....	6.2.29
	Honeycombs .....	6.2.29
	Pop-outs.....	6.2.29
	Wear .....	6.2.30
	Collision Damage .....	6.2.30



	Abrasion .....	6.2.31
	Overload Damage.....	6.2.32
	Internal Steel Corrosion.....	6.2.33
	Loss of Prestress.....	6.2.33
	Carbonation .....	6.2.34
	Other Causes of Concrete Deterioration.....	6.2.34
	Chemical Attack.....	6.2.34
	Moisture Absorption.....	6.2.35
	Differential Foundation Movement .....	6.2.35
	Design and Construction Deficiencies.....	6.2.35
	Unintended Objects in Concrete .....	6.2.36
	Fire Damage.....	6.2.36
6.2.7	Protective Systems.....	6.2.36
	Types and Characteristics of Concrete Coatings.....	6.2.36
	Paint .....	6.2.36
	Oil-based Paint .....	6.2.36
	Latex Paint.....	6.2.36
	Epoxy Paint .....	6.2.37
	Urethanes.....	6.2.37
	Water Repellent Sealers .....	6.2.38
	Types and Characteristics of Reinforcement Coatings.....	6.2.38
	Epoxy Coating .....	6.2.38
	Galvanizing.....	6.2.39
	Stainless Steel Cladding.....	6.2.39
	Cathodic Protection.....	6.2.39
	Anodic Protection .....	6.2.40
6.2.8	Inspection Methods for Concrete and Protective Coatings.....	6.2.40
	Visual Examination .....	6.2.40
	Physical Examination .....	6.2.40
	Advanced Inspection Methods .....	6.2.41
	Physical Examination of Protective Coatings .....	6.2.43
	Areas to Inspect.....	6.2.43
	Coating Failures .....	6.2.43

# Topic 6.2 Concrete

## 6.2.1

### Introduction

A large percentage of the bridge structures in the nation's highway network are constructed of reinforced concrete or prestressed concrete. It is important that the bridge inspector understand the basic characteristics of concrete in order to efficiently inspect and evaluate a concrete bridge structure.

Concrete, commonly mislabeled as "cement", is a mixture of various components that, when mixed together in the proper proportions, chemically react to form a strong durable construction material ideally suited for certain bridge components. Cement is only one of the basic ingredients of concrete. It is the "glue" that binds the other components together. Concrete is made up of the following basic ingredients:

- Portland cement
- Water
- Air
- Aggregates
- Admixtures (reducers, plasticizers, retarders, pozzolans)

### Portland Cement

The first ingredient, Portland Cement, is one of the most common types of cement, and it is made with the following raw materials:

- Limestone - provides lime
- Quartz or cement rock - provides silica
- Claystone - provides aluminum oxide
- Iron ore - provides iron oxide

The cement is produced by placing the above materials through a three process high temperature kiln system. During the three process kiln system, the temperature can range from 212 to 2750 degrees Fahrenheit. The first zone in the kiln process is known as the drying process. During this process, the materials are dehydrated due to the high temperature. The calcining zone is the next step and results in the production of lime and magnesia. The final step, called the burning zone or clinkering zone, produces clinkers or nodules of the sintered materials. Upon cooling, the clinkers are ground into a powder and finish the Portland cement production process.

### Water

The second ingredient, water, can be almost any potable water. Impurities in water, such as dissolved chemicals, salt, sugar, or algae, produce a variety of undesirable effects on the quality of the concrete mix. Therefore, water with a noticeable taste or odor may be suspect.

## **Air**

The third ingredient of concrete is air. Small evenly distributed amounts of entrained air provide:

- Increased durability against freeze/thaw effects
- Reduced cracking
- Improved workability
- Reduced water segregation

Air entrainment also reduces the weight of concrete slightly. Many tiny air bubbles introduced into the plastic concrete naturally create lighter weight concrete. The typical air entrainment additive is a vinsol resin. Air entrainment additives act like dishwashing liquids. When mixed with water, they create bubbles. These bubbles become part of the concrete mix, creating tiny air voids. Through extensive lab testing, it has been proven that when exposed to freeze/thaw conditions, the voids prevent excess pressure buildup in the concrete.

## **Aggregates**

The fourth ingredient, aggregates, comprise approximately 75 percent of a typical concrete mix by volume. Some aggregate qualities which result in a strong and durable concrete are:

- Abrasion resistance
- Weather resistance
- Chemical stability
- Chunky compact shape
- Smooth, non-porous surface texture
- Cleanliness and even gradation

Normal weight concrete has a unit weight of approximately 140 to 150 pcf. Typical aggregate materials for normal weight concrete are sand, gravel, crushed stone, and air-cooled, blast-furnace slag. Ingredients such as sand is considered a 'fine' aggregate. Other aggregates are considered 'course' aggregates.

Lightweight concrete normally has a unit weight of 75 to 115 pcf. The weight reduction comes from the aggregates and air entrainment. Lightweight aggregates differ depending on the location where the lightweight concrete is being produced. The common factor in lightweight aggregates is that they all have many tiny air voids in them that make them lightweight with a low specific gravity.

## **Admixtures**

The fifth ingredient of most concrete mixes is one or more admixtures to change the consistency, setting time, or strength of concrete. Pozzolans are a common type of admixture used to reduce permeability. There are natural pozzolans such as diatomite and pumicite, along with artificial pozzolans which include admixtures such as fly ash.

Admixtures can either be minerals or chemicals. The mineral admixtures include fly ash, silica fume, and ground granulated blast-furnace slag. Chemical admixtures can include water reducers, plasticizers, retarders, high range water reducers, and superplasticizers.

Fly ash is a by-product from the burning of ground or powdered coal. Fly ash was added to concrete mixes as early as the 1930's. This turned out to be a viable way to dispose of fly ash while positively affecting the concrete. The use of fly ash in concrete mixes improves concrete workability, reduces segregation, bleeding, heat evolution and permeability, inhibits alkali-aggregate reaction, and enhances sulfate resistance.

The use of fly ash in concrete mixes also has some drawbacks, however, such as increased set time and reduced rate of strength gain in colder temperatures. Admixture effects are also reduced when fly ash is used in concrete mixes. This means, for example, that a higher percentage of air entrainment admixture is needed for concrete mixes using fly ash.

Silica fume (microsilica) results from the reduction of high purity quartz with coal in electric furnaces while producing silicon and ferrosilicon alloys. It affects concrete by improving compressive strength, bond strength, and abrasion resistance. Microsilica also reduces permeability. Concrete with a low permeability minimizes steel reinforcement corrosion, which is of major concern in areas where deicing agents are used. These properties have contributed to the increased use of high performance concrete in recent bridge design and construction.

Some disadvantages that result from the use of silica fume include a higher water demand in the concrete mix, a larger amount of air entraining admixture, and a decrease in workability.

Ground granulated blast-furnace slag is created when molten iron blast furnace slag is quickly cooled with water. This admixture can be substituted for cement on a 1:1 basis. However, it is usually limited to 25 percent in areas where the concrete will be exposed to deicing salts and to 50 percent in areas that do not need to use deicing salts.

Water reducing admixtures and plasticizers are used to aid workability at lower water/cement ratios, improve concrete quality and strength using less cement content, and help in placing concrete in adverse conditions. These admixtures can be salts and modifications of hydroxylized carboxylic acids, or modifications of lignosulfonic acids, and polymeric materials. Some of the potentially negative effects that are encountered when using water reducers and plasticizers include loss of slump and excess setting time.

Retarding admixtures are used to slow down the hydration process while not changing the long-term mechanical properties of concrete. This type of admixture is needed when high temperatures are expected during placing and curing. Retarders slow down the setting time to reduce unwanted temperature and shrinkage cracks which result from a fast curing mix.

## 6.2.2

### **Basic Shapes Used in Bridge Construction**

As a bridge construction material, the most basic shapes used for concrete members are either round or rectangular.

#### **Round**

Round shaped members are most commonly used in substructures and are cast-in-place. Common uses of round concrete members in bridge construction are piles or pier columns. (see Figure 6.2.1)



**Figure 6.2.1** Round Concrete Members

#### **Rectangular**

Rectangular shaped members can be used for both superstructure and substructure bridge elements and are cast-in-place. Common uses of this shape in bridge construction can include beams/girders, pier caps, piles, and columns. (see Figure 6.2.2)



**Figure 6.2.2** Rectangular Concrete Members

### 6.2.3

## Properties of Concrete

It is necessary for the bridge inspector to understand the different physical and mechanical properties of concrete and how they relate to concrete bridges in service today.

### Physical Properties

The major physical properties of concrete are:

- Thermal expansion - concrete expands as temperature increases and contracts as temperature decreases
- Porosity - because of entrapped air, the cement paste never completely fills the spaces between the aggregate particles, permitting absorption of water and the passage of water under pressure
- Volume changes due to moisture - concrete expands with an increase in moisture and contracts with a decrease in moisture
- Fire resistance - quality concrete is highly resistant to the effects of heat; however, temperatures over 700 degrees Fahrenheit may cause damage
- Formability - concrete can be cast to almost any shape prior to curing

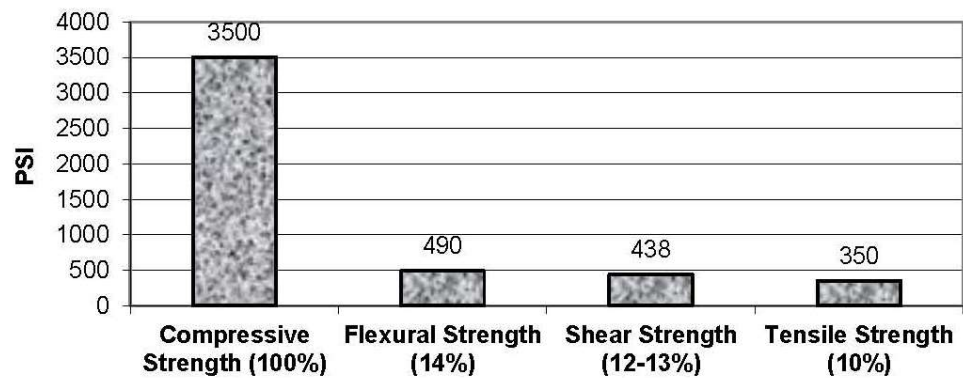
### Mechanical Properties

The major mechanical properties of concrete are:

- Strength - Plain, unreinforced concrete has a 28-day compressive strength ranging from about 2500 psi to about 6000 psi. Higher strength concrete, with compressive strengths ranging from 6000 psi to about 20,000 psi, is also available and becoming more commonly used. However, its tensile strength is only about 10 percent of its compressive strength, its shear strength is about 12 percent to 13 percent of its compressive strength, and its flexural strength is about 14 percent of its compressive strength (see Figure 6.2.3).

Six principal factors that increase concrete strength are:

- Increased cement content
  - Increased aggregate strength
  - Decreased water-to-cement ratio
  - Decreased entrapped air
  - Increased curing time (extent of hydration)
  - Use of pozzolanic admixtures and slag
- Elasticity - Within the range of normal use, concrete is able to deform a limited amount under load and still return to its original orientation when the load is removed (elastic deformation). Elasticity varies as the square root of compressive strength. See Topic 5.1 for modulus of elasticity and how it affects elastic deformation.
  - Creep - In addition to elastic deformation, concrete exhibits long-term, irreversible, continuing deformation under application of a sustained load. Creep (plastic deformation) ranges from 100 percent to 200 percent of initial elastic deformation, depending on time.
  - Isotropy - Plain, unreinforced concrete has the same mechanical properties regardless of which direction it is loaded.



Note: Percentages represent a comparison of various strength properties with the compressive strength of concrete.

**Figure 6.2.3** Strength Properties of Concrete (3500 psi Concrete)

### High Performance Concrete

High performance concrete (HPC) has been used for more than 30 years in the building industry. Under the FHWA's Strategic Highway Research Program (SHRP) Implementation Program, four types of high performance concrete mix designs were developed (see Figure 6.2.4). High performance concrete is distinguished from regular concrete by its curing conditions and proportions of the ingredients in the mix design. The use of fly ash and high range water reducers play an important role in the design of HPC, as well as optimizing all components of the mix. Due to the increased strength and reduced permeability of HPC, bridge decks using HPC are expected to have twice the life of conventional concrete bridge decks. The type and strength characteristics of concrete used to construct

bridge components can be found in the bridge file under design specifications or in construction plans and specifications.

HPC Type	Minimum Strength Criteria	Water-Cementitious Ratio	Minimum Durability Factor
Very Early Strength (VES)	2,000 PSI / 6 hours	≤ 0.4	80%
High Early Strength (HES)	5,000 PSI / 24 hours	≤ 0.35	80%
Very High Strength (VHS)	10,000 PSI / 28 days	≤ 0.35	80%
Fiber Reinforced	HES + (steel or poly)	≤ 0.35	80%
<b>Additional information on the definition of HPC:</b>			
<ul style="list-style-type: none"> <li>- "HPC Defined for Highway Structures," Charles Goodspeed, Suneel Vanikar, and Ray Cook; <i>Concrete International</i>, February 1996, <a href="#">The American Concrete Institute</a>.</li> <li>- "Workshop Showcases High-Performance Concrete Bridges," <i>Focus Newsletter</i>, May 1996.</li> </ul>			

**Figure 6.2.4** FHWA's Strategic Highway Research Program (SHRP) Implemented HPC Mix Designs

**Ultra-High Performance Concrete**

Ultra-high performance concrete (UHPC) has exceedingly high durability and compressive strength. This form of concrete is a high strength, ductile material that is formulated from a special combination of constituent materials which include Portland cement, silica fume, quartz flour, fine silica sand, high-range water-reducer, water, and either steel or organic fibers.

UHPC has compressive strengths of 18,000 psi to 33,000 psi and flexural strengths of 900 to 7,000 psi, which depends on the type of fibers that are being used and if a secondary treatment is used to help further develop compressive strength. UHPC also has the capability to sustain deformations and resist flexural and tensile stresses, even after it initially cracks.

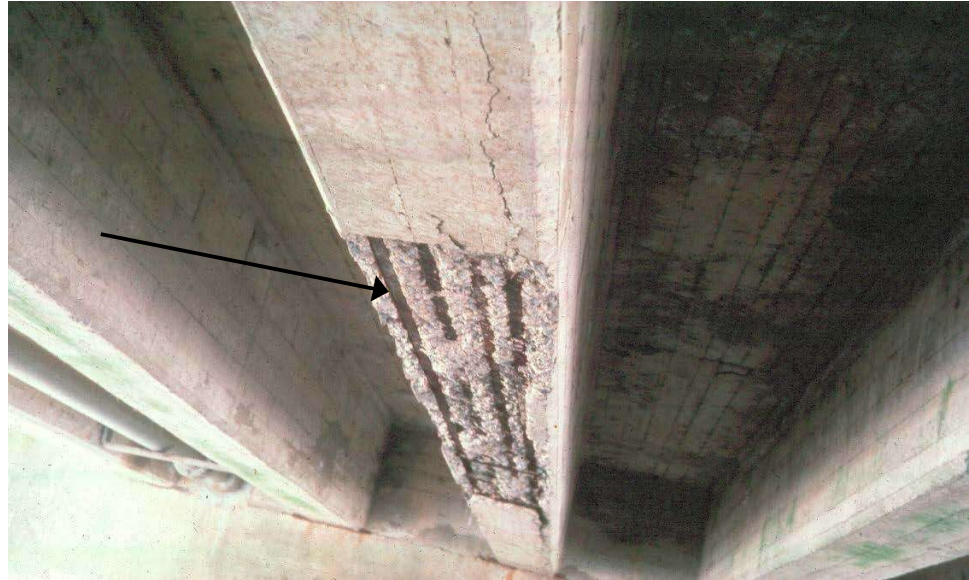
**6.2.4 Reinforced Concrete**

Concrete is commonly used in bridge applications due to its compressive strength properties. However, in order to supplement the limited tensile, shear and flexural strengths of concrete, reinforcement is used.

**Conventionally Reinforced Concrete**

Current steel reinforcement has a tensile yield strength of 60 ksi or 75 ksi and therefore has approximately 100 times the tensile strength of commonly used concrete. Older structures use a reinforcement that has tensile yield strength of 40 ksi. Stainless steel reinforcement (40 ksi to 75 ksi) is gaining popularity due to estimates by manufacturers that it has a service life of 100 years. Therefore, in conventionally reinforced concrete members, the concrete resists the compressive forces and the steel reinforcement primarily resists the tensile forces. The type of steel reinforcement used in conventionally reinforced concrete is "mild steel", which is a term used for low carbon steels. The steel reinforcement is located close to the tension face of a structural member to maximize its efficiency (see Figure 6.2.5).



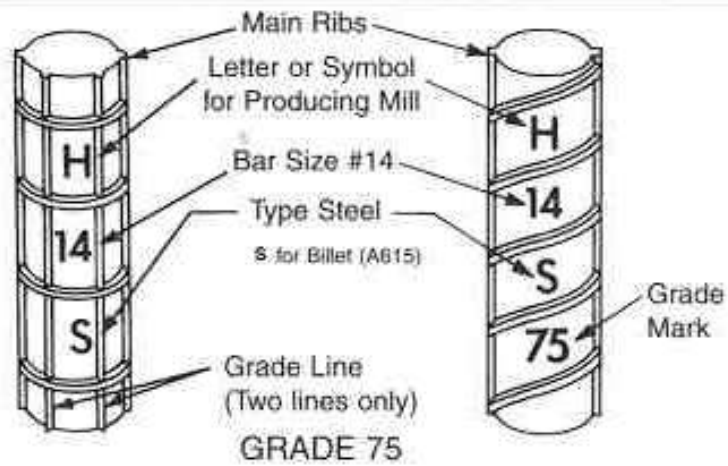
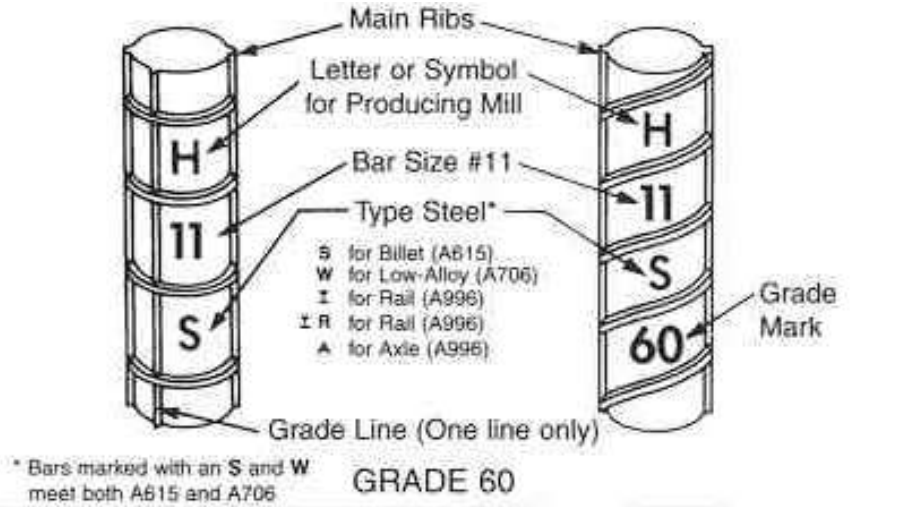


**Figure 6.2.5** Concrete Member with Tensile Steel Reinforcement Showing

Shear reinforcement is also needed to resist diagonal tension (refer to Topic 3.1). Shear cracks start at the bottom of concrete members near the support and propagate upward and away from the support at approximately a 45 degree angle. Vertical or diagonal shear reinforcement is provided in this area to intercept the cracks and to stop crack initiation and propagation.

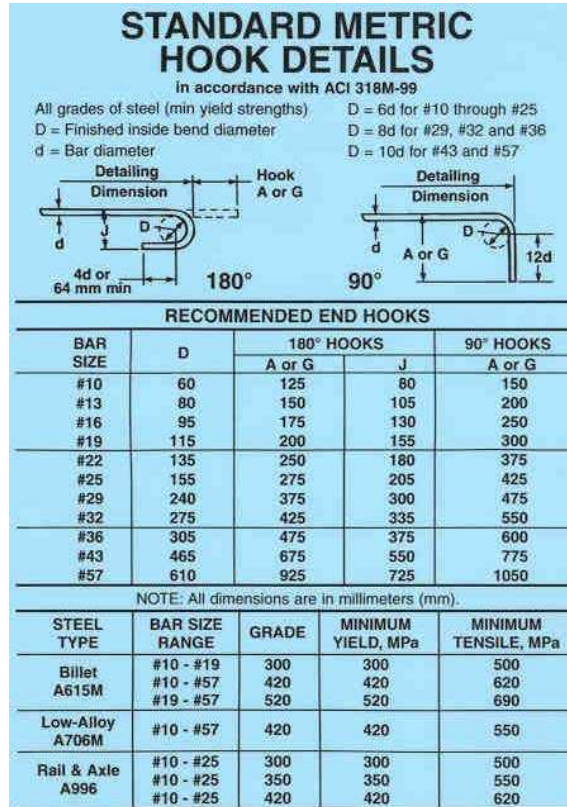
Reinforcing bars are also placed uniformly around the perimeter of a member to resist stresses resulting from temperature changes and volumetric changes of concrete. This steel is referred to as temperature and shrinkage steel.

Steel reinforcing bars can be "plain" or smooth surfaced, or they can be "deformed" with a raised gripping pattern protruding from the surface of the bar (see Figure 6.2.6). The gripping pattern improves bond with the surrounding concrete. Modern reinforced concrete bridges are constructed with "deformed" reinforcing steel.



INCH-POUND BAR SIZE	DIAMETER (in.)	AREA (in. <sup>2</sup> )
#3	0.375	0.11
#4	0.500	0.20
#5	0.625	0.31
#6	0.750	0.44
#7	0.875	0.60
#8	1.000	0.79
#9	1.128	1.00
#10	1.270	1.27
#11	1.410	1.56
#14	1.693	2.25
#18	2.257	4.00

Figure 6.2.6 Standard Deformed Reinforcing Bars (Source: Concrete Reinforcing Steel Institute)



### STANDARD HOOK DETAILS

in accordance with ACI 318-99

All grades of steel (min yield strengths)      D = 6d for #3 through #8  
D = Finished inside bend diameter              D = 8d for #9, #10 and #11  
d = Bar diameter                                      D = 10d for #14 and #18

**Figure 6.2.7** Standard Deformed Reinforcing Bars (Source: Concrete Reinforcing Steel Institute) (Continued)

In US units, reinforcing bars up to 1-inch nominal diameter are identified by numbers that correspond to their nominal diameter in eighths of an inch. For example, a #4 bar has a 1/2-inch nominal diameter (or 4 times 1/8 of an inch). For the remaining bar sizes (#9, #10, #11, #14, and #18), the area is equivalent to the old 1, 1-1/8, 1-1/4, 1-1/2, and 2-inch square bars, respectively.

Reinforcing bars can also be used to increase the compressive strength of a concrete member. When reinforcing bars are properly incorporated into a concrete member, the steel and concrete acting together provide a strong, durable construction material.

Reinforcing bars can be protected or unprotected from corrosion. Unprotected reinforcement is referred to as “black” steel because only mill scale is present on the surface.

The deformed epoxy coated bar is the most common type of protected reinforcing bar used. It is commonly specified when a concrete member may be exposed to an adverse environment. The epoxy provides a protective coating against corrosion agents such as de-icing chemicals and brackish water, and is inexpensive compared to other protective coatings. Another type of protected reinforcing bar is the galvanized bar. Unprotected bars are given a zinc coating, which slows down or stops the corrosion process. Stainless steel reinforcement is another type of reinforcement bar that allows protection from the adverse environments. Stainless steel reinforcement has greater corrosion resistance than that of conventional reinforcement and has an estimated service life of 100 years.

### **Fiber Reinforced Polymer Applications**

Deterioration in concrete members is primarily caused by corrosion of conventional reinforcement. Fiber reinforced polymer (FRP) composite reinforcement is becoming increasingly popular since it does not corrode like conventional reinforcement. See Topic 6.6.1 for a detailed description of fiber reinforced polymer reinforcement applications.

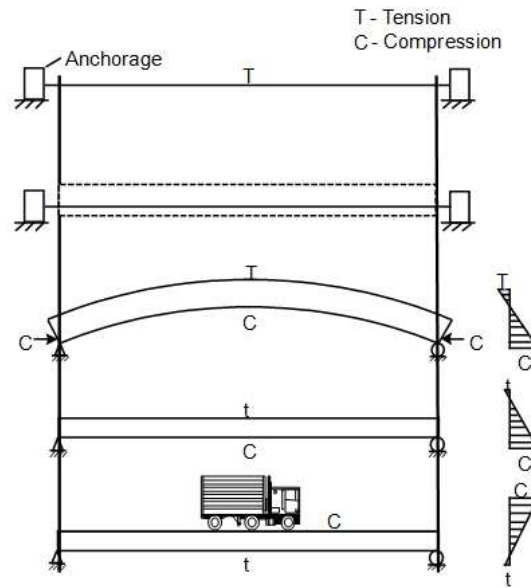
### **6.2.5**

### **Prestressed Concrete**

Another type of concrete used in bridge applications is prestressed concrete, which uses high tensile strength steel strands as reinforcement. To reduce the tensile forces in a concrete member, internal compressive forces are induced through prestressing steel tendons or strands. When loads are applied to the member, any tensile forces developed are counterbalanced by the internal compressive forces induced by the prestressing steel. By prestressing the concrete in this manner, the final tensile forces under primary live loads are typically within the tensile strength limits of plain concrete. Therefore, properly designed prestressed concrete members do not develop flexure cracks under service loads (see Figure 6.2.8).

### Pretensioned Beam

1. Steel stretched below yield strength
2. Concrete is placed and cured (no stress in concrete)
3. Steel is cut (compression in majority of beam)
4. Dead load + prestress
5. Dead load, prestress, and live load

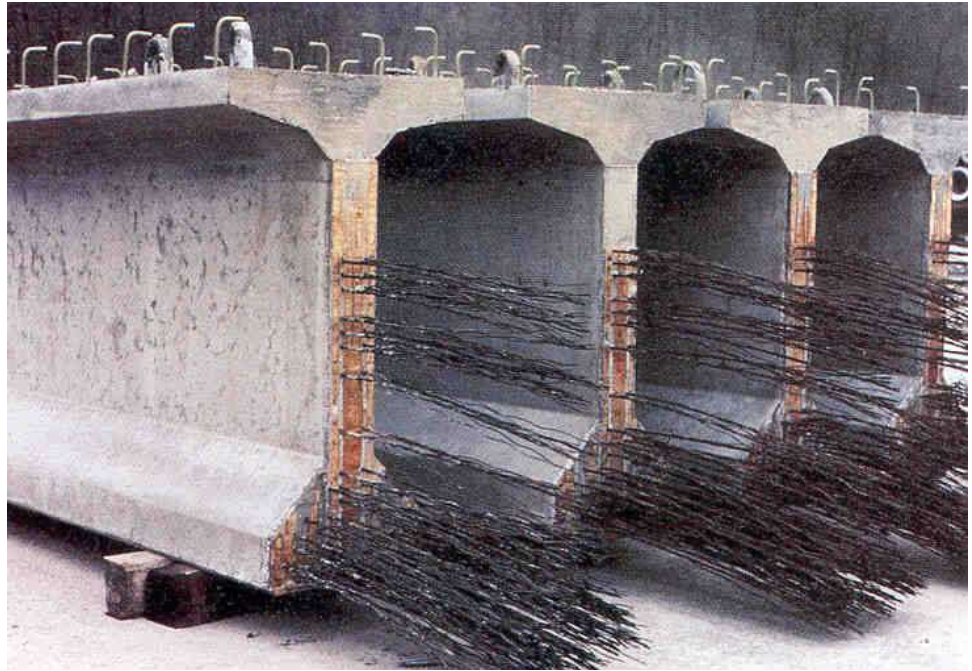


**Figure 6.2.8** Prestressed Concrete Beam

### **Prestressing Methods**

There are three methods of prestressing concrete:

- Pretensioning - during fabrication of the member, prestressing steel is placed and tensioned prior to casting and curing of the concrete (see Figure 6.2.9)
- Post-tensioning - during fabrication of the member, ducts are cast-in-place so that after curing, the prestressing steel can be passed through the ducts and tensioned (see Figure 6.2.10)
- Combination method - this is used for long members for which the required prestressing force cannot safely be applied using pretensioning only or construction method such as for a spliced bulb-T which would require post-tensioning



**Figure 6.2.9** Pretensioned Concrete I-Beams



**Figure 6.2.10** Post-tensioned Concrete Box Girders

### **Prestressing Reinforcement**

Steel for prestressing, which is named high tensile strength steel, comes in three basic forms:

- Wires (ASTM A421) - single wires or parallel wire cables; the parallel wire cables are commonly used in prestressing operations; the most popular wire size is 1/4-inch diameter and the most common grade of steel is the 270 ksi grade.

- Strands (ASTM A416) - fabricated by twisting wires together; the seven wire strand is the most common type of prestressing steel used in the United States, and the 270 ksi grade is most commonly used today.
- Bars (ASTM A322 and A29) - high tensile strength bars typically have a minimum ultimate stress of 145 ksi; the bars have full length deformations that also serve as threads to receive couplers and anchorage hardware

Epoxy coated prestressing strand is a newer alternative to help minimize the amount of corrosion that occurs to otherwise unprotected strands. The epoxy is applied to the ordinary seven wire low relaxation prestressing strand through a process called “fusion bonding”. Once the epoxy is applied, the strand has very little bond capacity and an aluminum oxide grit has to be applied to aid in the bonding. From recent testing by the FHWA, the epoxy coated strands have a tendency to slip when advanced curing temperatures are 145 degrees Fahrenheit and above. This slip occurs because the epoxy material begins to melt at these temperatures. Since the epoxy coating has a tendency to melt, this type of alternative is not used unless protection of the prestressing strand is critical.

In pretensioned members, transfer of tendon tensile stress occurs through bonding, which is the secure interaction of the prestressing steel with the surrounding concrete. This is accomplished by casting the concrete in direct contact with the prestressed steel.

For purposes of crack control in end sections of pretensioned members, the prestressing steel is sometimes debonded. This is accomplished by providing a protective cover on the steel, preventing it from contacting the concrete. Crack control at the beam ends may also be obtained by using draped strands. A number of strands are draped from both ends of the beam to the beam’s third points resulting in end strand patterns with center of gravities near the beam center of gravity.

In post-tensioned members, transfer of tendon tensile stress is accomplished by mechanical end anchorages and locking devices. If bonding is also desired, special ducts are used which are pressure injected with grout after the tendons are tensioned and locked off.

For post-tensioned members, when bonding is not desirable, grouting of tendon ducts is not performed and corrosion protection in the form of galvanizing, greasing, or some other means must be provided.

In prestressed concrete beams, shear strength is enhanced by the local compressive stress present. However, mild shear reinforcement is still required. Similar to reinforced concrete, prestressed concrete also requires mild steel temperature and shrinkage reinforcement.

## 6.2.6

### **Anticipated Modes of Concrete Deficiencies**

In order to properly inspect a concrete bridge, the inspector needs to be able to recognize the various types of deficiencies associated with concrete. The inspector also needs to understand the causes of the deficiencies and how to examine them. There are many common deficiencies that occur on reinforced concrete bridges:

- Cracking (structural, flexure, shear, crack size, nonstructural, crack orientation)
- Scaling
- Delamination
- Spalling
- Chloride contamination
- Freeze-thaw
- Efflorescence
- Alkali-Silica Reactivity (ASR)
- Ettringite formation
- Honeycombs
- Pop-outs
- Wear
- Collision damage
- Abrasion
- Overload damage
- Internal steel corrosion
- Loss of prestress
- Carbonation
- Other causes (temperature changes, chemical attack, moisture absorption, differential foundation movement, design and construction deficiencies, unintended objects in concrete, fire damage)

### **Cracks**

A crack is a linear fracture in concrete. It may extend partially or completely through the member. There are two basic types of cracks: structural and non-structural cracks. Structural cracks are caused by dead load and live load stresses. Cracking is considered normal for conventionally reinforced concrete (e.g., in cast-in-place tee-beams) as long as the cracks are small and there are no rust stains or other signs of deterioration present. Larger structural cracks indicate potentially serious problems, because they are directly related to the structural capacity of the member. When cracks can be observed opening and closing under load, they are referred to as “working” cracks. There are two types of structural cracks: flexure and shear (see Figure 6.2.11). Cracks caused by dimensional changes due to shrinkage or temperature are considered nonstructural cracks.



### Flexure Cracks

Flexure cracks are considered structural cracks and are caused by tensile forces and therefore develop in the tension zones. Tension zones occur either on the bottom or the top of a member, depending on the span configuration. Tension zones can also occur in substructure components. Tension cracks terminate when they approach the neutral axis of the member. If a beam is a simple span structure (refer to Topic 5.1.9), flexure cracks can often be found at the mid-span at the bottom of the member where bending or flexure stress is greatest (see Figure 6.2.12). If the beams are continuous span structures (refer to Topic 5.1.9), flexure cracks can also occur at the top of members at or near their interior supports.

### Shear Cracks

Shear cracks are considered structural cracks and are caused by diagonal tensile forces that typically occur in the web of a member near the supports where shear stress is the greatest. Normally, these cracks initiate near the bearing area, beginning at the bottom of the member, and extending diagonally upward toward the center of the member (see Figure 6.2.13). Shear cracks also occur in abutment backwalls, stems and footings, pier caps, columns, and footings.

Although structural cracks are typically caused by dead load and live load forces, they can also be caused by overstresses in members resulting from unexpected secondary forces. Restricted thermal expansion or contraction such as caused by frozen bearings, or forces due to the expansion of an approach slab or failure of a backwall can induce significant forces which result in cracks.

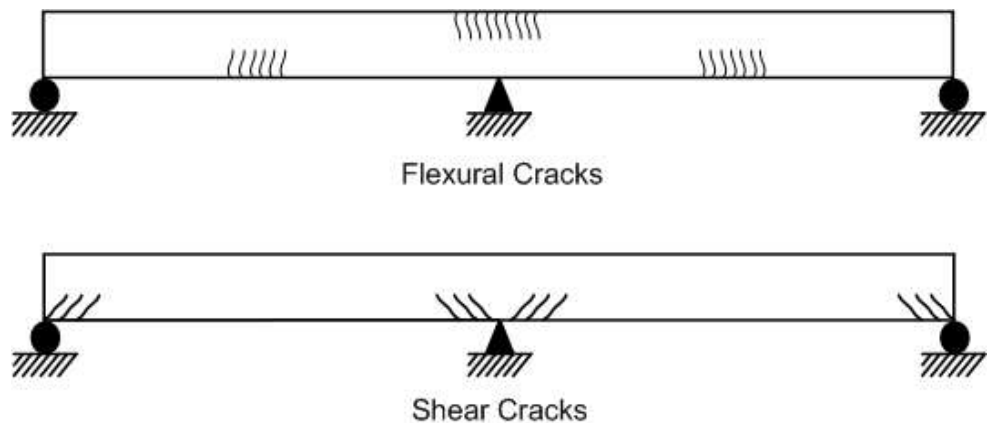
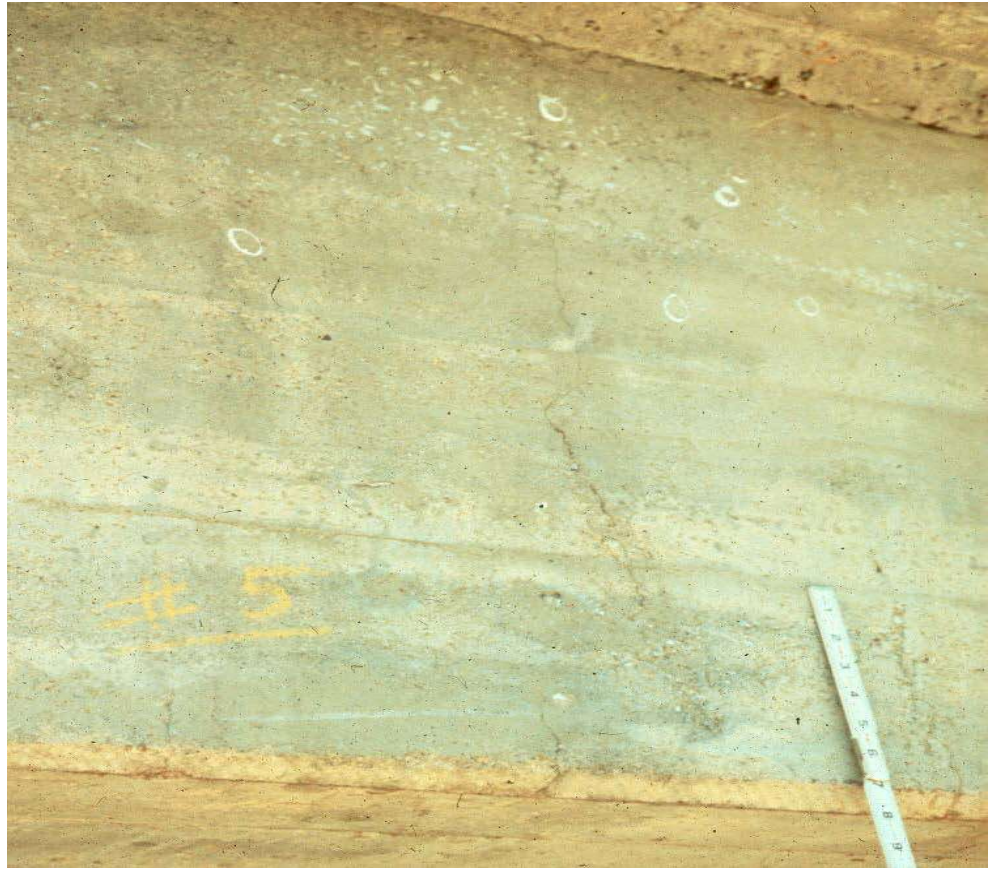


Figure 6.2.11 Structural Cracks



**Figure 6.2.12** Flexural Crack on a Tee Beam



**Figure 6.2.13** Shear Crack on a Slab

### Crack Size

Crack size is very important in assessing the condition of an in-service bridge. A crack comparator card can be used to measure and differentiate cracks (see Figure 6.2.14).



**Figure 6.2.14** Crack Comparator Card

According to the Unpublished Draft Guidelines for NCHRP Project 12-82, *Developing Reliability-Based Bridge Inspection Practices*, "engineering judgment [is] exercised in determining whether any present flexural cracking is moderate to severe. Crack widths in reinforced concrete bridges exceeding 0.006 inches to 0.012 inches reflect the lower bound of moderate cracking. The American Concrete Institute Committee Report 224R-01 presents guidance for what could be considered reasonable or tolerable crack widths at the tensile face of reinforced concrete structures for typical conditions. These range from 0.006 inches for marine or seawater spray environments to 0.007 inches for structures exposed to de-icing chemicals, to 0.012 inches for structures in a humid, moist environment.

In prestressed concrete bridge structural elements, tolerable crack [...] criteria [has] been adopted in the Precast Prestressed Concrete Institute (PCI) MNL-37-06, *Manual for the Evaluation and Repair of Precast Prestressed Concrete Bridge Products*. The PCI Bridge Committee recommends that flexural cracks greater in width than 0.006 inches [...] be evaluated to affirm adequate design and performance.

Generally, cracking in prestressed elements is more problematic than cracking in reinforced concrete elements.

In cases where flexural cracking is minor or appropriate assessment has indicated that the cracking is not affected the adequate load capacity of the element, the cracking provides pathways for the ingress of moisture and chlorides that may cause corrosion of the embedded steel. This attribute is intended to consider the increased likelihood of corrosion resulting from the cracking in the concrete."

Record the length, width, location, and orientation (horizontal, vertical, or diagonal) when reporting cracks. Carefully record cracks in main members or primary members. Document if the crack extends partially or completely through the member. Indicate the presence of rust stains or efflorescence or evidence of possible reinforcement section loss.

### **Nonstructural Cracks**

Nonstructural cracks result from internal stresses due to dimensional changes. Nonstructural cracks are divided into three categories:

- Temperature cracks (see Figure 6.2.15)
- Shrinkage cracks (see Figure 6.2.16)
- Mass concrete cracks

Though these cracks are nonstructural and relatively small in size, they provide openings for water and contaminants, which can lead to serious problems. Temperature cracks are caused by the thermal expansion and contraction of the concrete. Concrete expands or contracts as its temperature rises or falls. If the concrete is prevented from contracting, due to friction or because it is being held in place, it will crack under tension. Inoperative bearing devices and clogged expansion joints can also cause this to occur. Shrinkage cracks are due to the shrinkage of concrete caused by the curing process. Volume reduction due to curing is also referred to as plastic shrinkage. Plastic shrinkage cracks occur while the concrete is still plastic and are usually short, irregular shapes and do not extend the full depth into the member. Mass concrete cracks occur due to thermal gradients (differences between interior and exterior) in massive sections immediately after placement and for a period of time thereafter. Temperature, shrinkage, and mass concrete cracks typically do not significantly affect the structural strength of a concrete member.



**Figure 6.2.15** Temperature Cracks



**Figure 6.2.16** Shrinkage Cracks

Exercise care in distinguishing between nonstructural cracks and structural cracks. However, regardless of the crack type, water seeps in and causes the reinforcement to corrode. The corroded reinforcement expands and exerts pressure on the concrete. This pressure can cause delaminations and spalls.

### Crack Orientation

Structural cracks are usually oriented perpendicular to their stresses (i.e. tension or shear). Nonstructural cracks such as temperature and shrinkage cracks can occur in both the transverse and longitudinal directions. In retaining walls and abutments, these cracks are usually vertical, and in concrete beams, these cracks occur vertically or transversely on the member. However, since temperature and shrinkage stresses exist in all directions, the cracks could have other orientations.

In addition to classifying cracks as either structural or nonstructural and recording their lengths and widths, also describe the orientation of the cracks. The orientation of the crack with respect to the loads and supporting members is an important feature that is to be recorded accurately to ensure the proper evaluation of the crack. The orientation of cracks may generally be described by one of the following five categories:

- Transverse cracks – These are fairly straight cracks that are roughly perpendicular to the centerline of the bridge or a bridge member (see Figure 6.2.17).
- Longitudinal cracks - These are fairly straight cracks that run parallel to the centerline of the bridge or a bridge member (see Figure 6.2.18).
- Diagonal cracks - These cracks are skewed (at an angle) to the centerline of the bridge or a bridge member, either vertically or horizontally.
- Pattern or map cracking - These are inter-connected cracks that form networks of varying size. They vary in width from barely visible, fine cracks to cracks with a well defined opening. Map cracking resembles the lines on a road map (see Figure 6.2.19).
- Random cracks - These are meandering, irregular cracks. They have no particular form and do not logically fall into any of the types described above.



**Figure 6.2.17** Transverse Cracks



**Figure 6.2.18** Longitudinal Cracks



**Figure 6.2.19** Pattern or Map Cracks

### Scaling

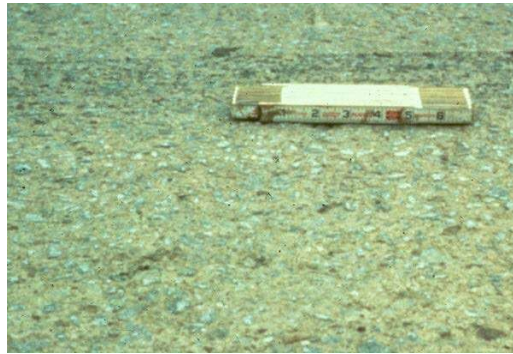
Scaling, also known as surface breakdown, is the gradual and continuing loss of surface mortar and aggregate over an area due to the chemical breakdown of the cement bond. Scaling is accelerated when the member is exposed to a harsh environment. Scaling is classified in the following four categories:

- Light or minor scale - loss of surface mortar up to 1/4-inch deep, with surface exposure of coarse aggregates (see Figure 6.2.20)
- Medium or moderate scale - loss of surface mortar from 1/4- inch to 1/2- inch deep, with mortar loss between the coarse aggregates (see Figure 6.2.21)
- Heavy scale - loss of surface mortar from 1/2-inch to 1-inch deep; coarse aggregates are clearly exposed (see Figure 6.2.22)
- Severe scale - loss of coarse aggregate particles, as well as surface mortar and the mortar surrounding the aggregates; depth of the loss exceeds 1 inch; reinforcing steel is usually exposed (see Figure 6.2.23)

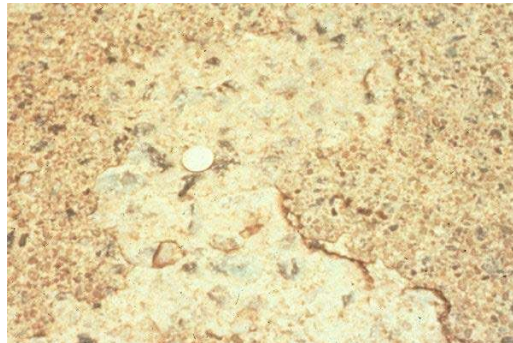




**Figure 6.2.20** Light or Minor Scaling



**Figure 6.2.21** Medium or Moderate Scaling



**Figure 6.2.22** Heavy Scaling



**Figure 6.2.23** Severe Scaling

When reporting scaling, note the location of the deficiency, the size of the affected area, and the scaling classification. For severe scale, the depth of penetration of the deficiency will also be recorded.

### **Delamination**

Delamination occurs when layers of concrete separate at or near the level of the outermost layer of reinforcing steel. The major cause of delamination is expansion of corroding reinforcing steel causing a break in the bond between the concrete and reinforcement. This is commonly caused by intrusion of chlorides or salt. Another cause of delamination is severe overstress in a member. Delaminated areas give off a hollow “clacking” sound when tapped with a hammer or chain drag. When a delaminated area completely separates from the member, the resulting depression is called a spall.

When reporting delamination, note the location and the size of the area.

### **Spalling**

A spall is a depression in the concrete (see Figure 6.2.24). Spalls result from the separation and removal of a portion of the surface concrete, revealing a fracture roughly parallel to the surface. Spalls can be caused by corroding reinforcement, friction from thermal movement, and overstress. Reinforcing steel is often exposed in a spall, and the common shallow pothole in a concrete deck is considered a spall. Spalls are classified as follows:

- Small spalls - not more than 1 inch deep or approximately 6 inches in diameter
- Large spalls - more than 1 inch deep or greater than 6 inches in diameter



**Figure 6.2.24** Spalling on a Concrete Deck

When concrete is overstressed, it gives or fractures. Over time, the fracture opens wider from debris, freeze/thaw cycles, or more overstress. This cycle continues until a spall is formed. Spalls caused from overstress are very serious and are to be brought to the attention of the Chief Bridge Engineer. Most spalls are caused from corroding reinforcement, but if the spall is located at or near a high moment region, overstress may be the cause. Examples that might indicate a spall was caused by overstress include:

- A spall that is at or near flexure cracks in the lower portion of a beam at mid-span
- A spall that is at or near flexure cracks in the top of a continuous member over a support

Similarly, when concrete is overstressed in compression, it is common for the surface to crush and then spall.

When reporting spalls, note the location of the deficiency, the size of the area, and the depth of the deficiency.

**Chloride Contamination** Chloride contamination in concrete is the presence of recrystallized soluble salts. Concrete is exposed to chlorides in the form of deicing salts, acid rain, and in some cases, contaminated water used in the concrete mix. During the 1960's, salt was added to water to prevent it from freezing during mixing and fabrication. Practices like these are no longer acceptable. Various admixtures are incorporated to account for adverse weather condition. This practice causes accelerated reinforcement corrosion that leads to cracking of the concrete.

**Freeze-Thaw** Freeze-thaw is the freezing water within the capillaries and pores of cement paste and aggregate resulting in internal overstraining of the concrete, which leads to deterioration including cracking, scaling, and crumbling. Pore pressure is a phenomenon that occurs during freeze-thaw which causes the deterioration and expansion of the concrete.

## Efflorescence

The presence of cracks permits moisture absorption and increased flow within the concrete that is evidenced by dirty-white surface deposits called efflorescence. Efflorescence is a combination of calcium carbonate leached out of the cement paste and other recrystallized carbonate and chloride compounds (see Figure 6.2.25). In order to estimate the percent of concrete contaminated by chloride, nondestructive testing is required (see Topic 15.2.2).



**Figure 6.2.25** Efflorescence

## Alkali-Silica Reaction

Alkali-Silica Reaction (ASR) is an expansive reaction, forming a gel, which will result in the swelling and expansion of concrete. (See Figure 6.2.26).

The process involves a reaction between potassium and sodium alkalis (common in cement) and silica (common in aggregates). Alkali found in soils, deicers, and chemical treatments could also contribute to ASR. In addition, salts have been also known to accelerate alkali-silica reactions. Moisture can also promote the expansion for a structure already affected by ASR.

Typical indicators are map cracking or scaling and in cases that are more advanced, closed joints and spalled concrete surfaces are typical indicators. Cracking may appear in areas where there is frequent moisture. There is no early indication of ASR visible, so lab testing will be required to confirm presence of ASR.

Even though there is no early detection, there is a process to confirm if ASR is present in concrete which consists of three different levels. First, there is a Level 1 investigation that is performed, which consists of a condition survey performed to evaluate distress. If further investigation is required, a Level 2 investigation will be conducted, which consists of documenting information, measuring the Cracking Index, obtain samples, and conduct a petrographic examination. After the first two levels of investigation are complete and further investigation is required, a Level 3 investigation is performed. Level 3 investigations will include determining the expansion to date, the current rate of expansion, and the potential for future expansion. It will be necessary to perform the test of the structure at the location of the ASR in order to gather all the information required to determine the growth of the ASR (Source: Report on Diagnosis, Prognosis, and Mitigation of Alkali-Silica Reaction (ASR) in Transportation Structures, Publication No. FHWA-HIF-09-004)



**Figure 6.2.26** Alkali-Silica Reaction (ASR)

### **Ettringite Formation**

Ettringite formation is an internal deficiency that occurs in concrete from the reaction of sulfates, calcium aluminates, and water. From this reaction, ettringite, which is a crystalline mineral, expands up to eight times in volume compared to the volume of the tricalcium nitrates ( $C_3A$ ). Ettringite formation is initially formed when water is added to the cement but prior to the concrete's initial set. The initial formation does not harm the concrete. A secondary or delayed ettringite formation occurs after the concrete has hardened. This formation creates very high forces in hardened concrete and is the cause of the deterioration. The only way to identify ettringite formation as a cause of premature concrete deterioration is through advanced inspection methods such as petrographic analysis. Recent studies have shown that ettringite formation is linked to alkali-silica reaction (ASR), but further research is still needed.

### **Honeycombs**

If the concrete is not properly vibrated, internal settling of the concrete mix can cause surface cracking above the reinforcing bars as the mix settles around the bars. Honeycombs or construction voids are hollow spaces or voids that may be present within the concrete. Honeycombs are construction deficiencies caused by improper vibration during concrete placement, resulting in the segregation of the coarse aggregates from the fine aggregates and cement paste. This can be attributed to excessive vibration. In some cases, honeycombs are the result of insufficient vibration, where the entire concrete mix does not physically reach the formwork surface (see Figure 6.2.27).



**Figure 6.2.27** Honeycomb

### **Pop-outs**

Pop-outs are conical fragments that break out of the surface of the concrete, leaving small holes. Generally, a shattered aggregate particle will be found at the bottom of the hole, with a part of the fragment still adhering to the small end of the pop-out cone. Pop-outs are caused by aggregates which expand with absorption of moisture. Other causes of pop-outs include use of reactive aggregates and high

alkali cement.

**Wear**

Wear is the gradual removal of surface mortar due to friction and occurs to concrete surfaces, like a bridge deck, when exposed to traffic. Advanced wear exhibits polished aggregate, which is potentially a safety hazard when the deck is wet. The scraping action of snowplows and street sweepers also wears the deck surface and damages curbs, parapets, and pier faces.

**Collision Damage**

Trucks, derailed railroad cars, or marine traffic may strike and damage concrete bridge components (see Figure 6.2.28). The damage is generally in the form of cracking or spalling, with exposed reinforcement. Prestressed beams are particularly sensitive to collision damage, as exposed tendons undergo stress corrosion and fail prematurely.



**Figure 6.2.28** Concrete Column Collision Damage

## Abrasion

Abrasion damage is the result of external forces acting on the surface of the concrete member and is similar to wear (see Figure 6.2.29). Erosive action of silt-laden water running over a concrete surface and ice flow in rivers and streams can cause considerable abrasion damage to concrete piers and pilings. In addition, concrete surfaces in surf zones may be damaged by the abrasive action of sand and silt in the water. Abrasion damage can be accelerated by freeze-thaw cycles. This will usually occur near the water line on concrete piers. The use of the term "scour" to indicate "abrasion" is incorrect. The term scour is used to describe the loss of streambed material from around the base of a pier or abutment due to stream flow or tidal action (see Topic 13.2).



**Figure 6.2.29** Substructure Abrasion



### Overload Damage

Overload damage or serious structural cracking occurs when concrete members are sufficiently overstressed. Concrete decks, beams, and girders are all subject to damage from such overload conditions. Note any excessive vibration or deflection that may occur under traffic, which can indicate overstress. Other visual signs that can indicate overstress due to tension include excessive sagging, spalling, and/or cracking at the mid-span of simple span structures and at the supports of continuous span structures. Diagonal cracks close to support points may be an indication of overstress due to shear or torsion. Permanent deformation is another visual sign of overstress damage in a member. If overload damage is detected or suspected, notify the Chief Bridge Engineer immediately (see Figure 6.2.30).



**Figure 6.2.30** Overload Damage

**Internal Steel Corrosion** Due to the chemistry of the concrete mix, reinforcing steel embedded in concrete is normally protected from corrosion. In the high alkaline environment of the concrete, a tightly adhering film forms on the steel that protects it from corrosion. However, this protection is eliminated by the intrusion of chlorides, which enables water and oxygen to attack the reinforcing steel, forming iron oxide (i.e., rust). Chloride ions are introduced into the concrete by marine spray, industrial brine, or deicing agents. These chloride ions can reach the reinforcing steel by diffusing through the concrete or by penetrating cracks in the concrete. An inspector may see a rebar rust stain on the outer concrete surfaces before a spall occurs. The corrosion product (rust) can occupy up to 10 times the volume of the corroded steel that it replaces. This expansive action creates internal pressures up to 3000 psi that will cause the concrete to yield, resulting in wider cracks, delaminations, and spalls (see Figure 6.2.31).



**Figure 6.2.31** Loss of Bond: Concrete / Corroded Reinforcing Bar

**Loss of Prestress**

Prestressed concrete members deteriorate in a similar fashion to conventionally reinforced concrete members. However, the effects on prestressed concrete member performance are usually more detrimental. Significant deficiencies include:

- Structural cracks
- Exposed prestressing tendons
- Corrosion of tendons in the bond zone
- Loss of camber due to concrete creep
- Loss of camber due to lost prestress forces

Structural cracks indicate an overload condition has occurred. These cracks

expose the tendons to the environment, which can lead to corrosion.

Exposed steel tendons via cracks or collision damage corrode at an accelerated rate due to the high tensile stresses carried and can fail prior to any measurable section loss due to environmentally induced cracking (EIC).

Environmentally induced cracking in steel prestressing strands can occur when the steel prestressing strands are subject to high tensile stresses in a corrosive environment. Rust stains may be present. The strands, which are normally ductile, undergo a brittle failure due to the combination of the corrosive environment along with the tensile stresses.

Forensic studies after a 2005 prestress beam failure determined that nominal tensile stress can be reduced to approximately 20 to 30 percent based on the condition of the prestress strands. Lightly corroded strands experienced a 20 percent reduction while heavy pitted strands experienced a 29 percent reduction in nominal tensile stress.

There are two types of environmentally induced cracking. The first is called stress corrosion cracking (SCC). This type of cracking grows at a slow rate and has a branched cracking pattern. The corrosion of prestressing steel along with the tensile stress in the steel causes a cracking pattern perpendicular to the stress direction.

The second type is called hydrogen-induced cracking (HIC) and occurs due to hydrogen diffusing into the prestressing steel. Once in the steel, hydrogen gas is formed. The hydrogen gas applies an internal pressure to the prestressing steel. This internal pressure, in conjunction with the tensile stress due to prestressing, has the ability to create very brittle, non-branching, fast growing cracks in the prestressing steel strands. The specific type of environmentally induced cracking can only be positively identified after failure through the use of advanced inspection methods.

When deteriorated concrete cover allows corrosion of the tendons in the bond zone (the end thirds of the beam), loss of development occurs which reduces prestress force. This can sometimes be evidenced by reduced positive camber and ultimately structural cracking. Prestress force can also be reduced through a beam-shortening phenomenon called creep, which relaxes the steel tendons. Loss of prestress force is followed by structural cracking at normal loads due to reduced live load capacity.

### **Carbonation**

Carbonation is a chemical reaction between carbon dioxide in the air with calcium hydroxide and hydrated calcium silicate in concrete. Carbon dioxide will react with the alkali in the cement which makes the pore water become more acidic, lowering the pH. The carbon dioxide will then start to carbonate the moment the concrete element is fabricated. Carbonation will start at the surface and move slowly deeper into the concrete, eventually reaching the reinforcement. Once it reaches the reinforcement, corrosion will begin to occur.

### **Other Causes of Concrete Chemical Attack Deterioration**

Aside from accelerated rebar corrosion, the use of salt or chemical deicing agents

contributes to weathering through recrystallization. This is quite similar to the effects of freezing and thawing.

Sulfate compounds in soil and water are also a problem. Sodium, magnesium, and calcium sulfates react with compounds in cement paste and cause rapid deterioration of the concrete.

### **Moisture Absorption**

All concrete is porous and will absorb water to some degree. As water is absorbed, the concrete will swell. If restrained, the material will burst or the concrete will crack. This type of deterioration is limited to concrete members that are continuously submerged in water.

### **Differential Foundation Movement**

Foundation movement can also cause serious cracking in concrete substructures. Differential settlement induces stresses in the supported superstructure and can lead to concrete deterioration. Cracks due to differential foundation movement are normally oriented in a vertical or diagonal direction.

### **Design and Construction Deficiencies**

Some conditions or improper construction methods that can cause concrete to deteriorate are:

- Insufficient reinforcement bar cover - Insufficient concrete cover over rebars may lead to early corrosion of the steel reinforcement which will result in cracking, delaminations and spalls.
- Weep holes and scuppers - Improper placement or inadequate sizing of scuppers and weep holes can cause an accumulation of water with its damaging effects.
- Leaking deck joints
- Improper curing - A primary cause of concrete deterioration (loss of strength) and excessive shrinkage cracking.
- Soft spots - Soft spots in the subgrade of an approach slab will cause the slab to settle and crack.
- Premature form removal - If the formwork is removed between the time the concrete begins to harden and the specified time for formwork removal, cracks will probably occur.
- Impurities - The inclusion of clay or soft shale particles in the concrete mix will cause small holes to appear in the surface of the concrete as these particles dissolve. These holes are known as mudballs.
- Internal voids - If reinforcing bars are too closely spaced, voids, which collect water, can occur under the reinforcing mat if the mix is not properly vibrated.

- Over finishing – This can lead to early scaling.

### **Unintended Objects in Concrete**

Some items discovered in concrete: screws, nails, tools, trash, paper, soft drink cans, etc. Objects like these can create voids and collect water or corrode and deteriorate concrete.

### **Fire Damage**

Extreme heat will damage concrete. High temperatures (above 700 degrees Fahrenheit) will cause a weakening in the cement paste and lead to cracking.

## **6.2.7**

### **Protective Systems**

---

#### **Types and Characteristics of Concrete Coatings**

Coatings form a protective barrier film on the surface of concrete to preclude entry of water and chlorides into the porous concrete. The practice of coating the concrete surface varies with each agency. Two primary concrete coatings are paint and water repellent sealers.

#### **Paint**

Paint is applied in one or two layers. The first layer fills the voids in a rough concrete surface. The second layer forms a protective film over the first. On smooth concrete surfaces, only one layer may be necessary. Consult the paint manufacturers prior to covering concrete to determine the best possible paint based upon the expected weather/exposure conditions and concrete type.

Several classes of paint are used to coat concrete:

- Oil-based paint
- Latex paint
- Epoxy paint
- Urethanes

#### **Oil-based Paint**

Oil-based paint is declining in use but is still found on some older concrete structures. Oil paint is subject to saponification failure in wet areas. Saponification is a chemical attack on the coating caused by the inherent alkalinity of the concrete. The moisture may be from humidity in the atmosphere, rain runoff, or ground water entering the porous concrete from below. Saponification does not occur over dry concrete (or occurs at a greatly reduced rate).

#### **Latex Paint**

Latex paint consists of a resin emulsion. Latexes can contain a variety of synthetic polymer binding agents. Latex paint resists attack by the alkaline concrete. Acrylic or vinyl latexes provide better overall performance, in that they are more resistant to alkaline attack than oil-based paint. Latex paints, however, are

susceptible to efflorescence. Efflorescing is a process in which water-soluble salts pass outward through concrete and are deposited at the concrete/paint interface. This can cause loss of coating adhesion. If the paint is also permeable to water, the salts are deposited on the paint surface as the water evaporates.

Acrylics do not chalk as rapidly as other latexes and have good resistance to ultraviolet rays in sunlight. Polyvinyl acetate latexes are the most sensitive to attack by alkalis.

### Epoxy Paint

Epoxy paint uses a cross-linking polymer binder, in which the epoxy resin in the paint undergoes a chemical reaction as the paint cures, forming a tough, cross-linked paint layer. Epoxies have excellent resistance to chemicals, water, and atmospheric moisture. Most epoxies are sensitive to the concrete's moisture content during painting. Polyamide-cured and water-base epoxy systems, however, have substantially overcome the moisture intolerance problem. For other epoxy systems, measure the concrete moisture prior to painting.

### Urethanes

Urethanes are usually applied over an epoxy primer. They provide excellent adhesion, hardness, flexibility, and resistance to sunlight, water, harmful chemicals, and abrasion. They are, however, sensitive to temperature and humidity during application. The urethanes used on concrete require moisture to cure. In high humidity, the paint cures too quickly, leaving a bubbly appearance.

Many states now apply moisture-cured urethane anti-graffiti coatings on accessible concrete structures (see Figure 6.2.32). These are smooth, clear coatings applied without a primer coat. Spray paint and indelible marker ink adhere poorly to the smooth urethane, permitting easier cleaning than if they were applied to porous concrete.



**Figure 6.2.32** Anti-Graffiti Coating on Lower Area of Bridge Piers

#### Water Repellent Sealers

Water repellent membranes (sealers) applied to concrete bridge decks, piers, abutments, columns, barriers, or aprons form a tight barrier to water and chlorides. The sealer penetrates up to  $3/8$  of an inch into the concrete to give strong adhesion. Sealers have good resistance to abrasion from weathering and traffic. Methyl methacrylate, silane, and silicone are three common water repellent sealers.

#### Types and Characteristics of Reinforcement Coatings

Because unprotected steel reinforcement corrodes and has adverse effects on concrete, some type of protective coating is used on steel reinforcement placed in concrete structures to ensure minimal steel corrosion. Steel reinforcement can be protected by the following methods:

- Epoxy coating
- Galvanizing
- Stainless steel cladding
- Cathodic protection
- Anodic protection

#### Epoxy Coating

Epoxy coating is resistant to chemicals, water, and atmospheric moisture. Epoxies utilize an epoxy polymer binder, which forms a tough, resilient film upon drying and curing. Drying is by solvent evaporation, while curing entails a chemical reaction between the coating components. Epoxy coatings have excellent atmospheric exposure characteristics, as well as resistance to chemicals and water. They are often used as the intermediate coat in a three layer paint system. There are also two- and three-layer systems, which use only epoxies. One disadvantage of epoxies is that they chalk when exposed to sunlight. This chalking must be removed prior to topcoating with another layer of epoxy or another material. If not

removed, the chalking will compromise subsequent adhesion.

### **Galvanizing**

Another method of protecting steel reinforcement is by galvanizing the steel. This also slows down the corrosion process and lengthens the life of the reinforced concrete. This occurs by coating the bare steel reinforcement with zinc. The two unlike metals form an electrical current between them and one metal virtually stops its corrosion process while the other's accelerates due to the electrical current. In this situation, the steel stops corroding, while the zinc has accelerated corrosion.

### **Stainless Steel Cladding**

Stainless steel cladding is another form of steel reinforcement protection that is resistant to corrosion. The chromium (Cr) in the coating will form a passivation layer chromium oxide ( $\text{Cr}_2\text{O}_3$ ) when exposed to oxygen which is not visible to the naked eye. The coating will protect the reinforcement from water and air and the coating will quickly reform if the surface is scratched.

### **Cathodic Protection**

Steel reinforcement corrosion can also be slowed down by cathodic protection. Corrosion of steel reinforcing bars in concrete occurs by an electrical process in a moist environment at the steel surface. During corrosion, a voltage difference (less than 1 volt) develops between rebars or between different areas on the same rebar. Electrons from the iron in the rebar are repelled by the negative anode area of the rebar and attracted to the positive cathode area. This electron flow constitutes an electrical current, which is necessary for the corrosion process. Corrosion occurs only at the anode, where the electrons from the iron are given up.

By cathodic protection, this electrical current is reversed, which slows or stops corrosion. By the impressed current method, an electrical DC rectifier supplies electrical current from local electrical power lines to a separate anode embedded in the concrete. The anode is usually a wire mesh embedded just under the concrete surface. Another type of anode consists of an electrically conductive coating applied to the concrete surface. The wires from the rectifier are embedded in the coating at regular intervals.

When the impressed current enters the mesh or coating anode, the voltage on the rebars is reversed, turning the entire rebar network into a giant cathode. Since natural corrosion occurs only at the anode, the rebars are protected.

The natural corrosion process is allowed to proceed with electrons leaving the iron atoms in the anode. With impressed current cathodic protection, however, the electrons are supplied from an external source, the DC rectifier. Thus, the artificial anode mesh or coating is also spared from corrosion.

During the bridge inspection, check that all visible electrical connections and wiring from the rectifier to the concrete structure are intact.



### **Anodic Protection**

Much like cathodic protection, this can help slow down the corrosion process of reinforcement. This is achieved by having a metal structure anode with a low voltage direct current so it can achieve and maintain an electrochemically passive state. Anodic protection can be more suitable than cathodic protection for reinforcement that is located in extremely corrosive environments. However, this will require careful monitoring and control, otherwise, it could hurry up the corrosion process.

## **6.2.8**

### **Inspection Methods for Concrete and Protective Coatings**

There are three basic methods used to inspect prestressed and reinforced concrete members. Depending on the type of inspection, the inspector may be required to use only one individual method or all methods. They include:

- Visual
- Physical
- Advanced inspection methods

#### **Visual Examination**

There are two types of visual inspections that may be required of an inspector. The first, called a routine inspection, involves reviewing the previous inspection report and visually examining the members from beneath the bridge. Give all concrete surfaces a thorough visual assessment to identify obvious surface deficiencies during a routine inspection.

The second type of visual inspection is called an in-depth inspection. An in-depth inspection is an inspection of one or more members above or below the water level to identify any deficiencies not readily detectable using routine methods. Hands-on inspection may be necessary at some locations. This type of visual inspection requires the inspector to visually assess all defective concrete surfaces at a distance no further than an arm's length. The concrete surfaces are given close visual attention to quantify and qualify any deficiencies. The hands-on inspection method may be supplemented by nondestructive testing.

#### **Physical Examination**

Physically examine areas of concrete or rebar deterioration that are identified visually by using an inspection hammer. This hands-on effort verifies the extent of the deficiency and its severity.

Sound high stress areas for deficiencies using an inspection hammer. Hammer sounding is commonly used to detect areas of delamination and unsound concrete. For large horizontal surfaces such as bridge decks, a chain drag may be used. A chain drag is made of several sections of chain attached to a handle (see Figure 6.2.33). The inspector drags this across a deck and makes note of the resonating sounds. A delaminated area will have a distinctive hollow "clacking" sound when tapped with a hammer or revealed with a chain drag. A hammer hitting sound concrete will result in a solid "pinging" type sound.

Give special attention to The location, length and width of cracks found during the visual inspection and sounding methods. For typical reinforced concrete members, a crack comparator card can be used to measure the width of cracks. This type of crack width measuring device is a transparent card about the size of an

identification card. The card has lines on it that represent crack widths. The line on the card that best matches the width of the crack lets the inspector know the measured width of the crack. For prestressed members, crack widths are usually narrower in width. For this reason, use a crack gauge, which is a more accurate crack width-measuring device.



**Figure 6.2.33:** Inspector Using a Chain Drag

### **Advanced Inspection Methods**

If the extent of the concrete deficiency cannot be determined by the visual and/or physical inspection methods described above, advanced inspection methods may be used. Nondestructive methods, described in Topic 15.2.2, include:

- Acoustic Wave Sonic/Ultrasonic Velocity Measurements
- Electrical Methods
- Delamination Detection Machinery
- Ground-Penetrating Radar
- Electromagnetic Methods
- Pulse Velocity
- Flat Jack Testing
- Impact-Echo Testing
- Infrared Thermography
- Laser Ultrasonic Testing
- Magnetic Field Disturbance
- Neutron Probe for Detection of Chlorides
- Nuclear Methods
- Pachometer

- Rebound and Penetration Methods
- Ultrasonic Testing
- Smart Concrete
- Carbonation

Other methods, described in Topic 15.2.3, include:

- Concrete Permeability
- Concrete Strength
- Endoscopes and Videoscopes
- Moisture Content
- Petrographic Examination
- Reinforcing Steel Strength
- Chloride Test
- Matrix Analysis
- ASR Evaluation

## Physical Examination of Protective Coatings

### Areas to Inspect

While inspecting protective coatings, pay close attention to the following areas:

- Areas open to direct weathering by wind, rain, hail, or seawater spray.
- Roadway splash zones along curbs, parapets, and expansion dams. These areas are subject to collision damage and coating removal from passing vehicles.
- Inaccessible or hard-to-reach areas where coatings may be missing or improperly applied.
- All concrete joints.
- Areas that retain moisture or salt. Horizontal surfaces of concrete beams and piers are common examples. Also inspect areas where drainage systems deposit salt and water, such as beneath catch basins, scuppers, downspouts, and bearing areas.
- Impact areas on bridge decks and parapets where snowplows or vehicle accidents damage coatings.

### Coating Failures

The following failures are characteristic of paint on concrete:

- Lack of adhesion/peeling can be caused by poor adhesion of the primer layer to the concrete or by poor bonding between coating layers. Waterborne salts depositing under a water-impermeable coating (efflorescence) will also cause a coating to peel.
- Chalking is a powdery residue left on paint as ultraviolet light degrades the paint.
- Erosion is a gradual wearing away of a coating. It is caused by abrasion from wind-blown sand, soil and debris, rain, hail, or debris propelled by motor vehicles.
- Checking is composed of short, irregular breaks in the top layer of paint, exposing the undercoat.
- Cracking is similar to checking, but with cracking, the breaks extend completely through all layers of paint to the concrete substrate.
- Microorganism failure occurs as bacteria and fungi feed on paint containing biodegradable components. The damp nature of concrete makes it susceptible to this type of paint failure.
- Saponification results from a chemical reaction between concrete, which is alkaline, and oil-based paint. It destroys the paint, leaving a soft residue.

Wrinkling is a rough, crinkled paint surface due to excessive paint thickness or high temperature during painting. It is caused by the surface of the paint film at the air interface solidifying before solvents have had a chance to escape from the interior of the paint film.

This page intentionally left blank.

# Table of Contents

## Chapter 6 Bridge Materials

---

6.3	Steel/Metal .....	6.3.1
6.3.1	Introduction.....	6.3.1
6.3.2	Common Methods of Steel Member Fabrication.....	6.3.1
	Rolled Shapes .....	6.3.1
	Built-Up Shapes .....	6.3.1
6.3.3	Common Steel Shapes Used in Bridge Construction.....	6.3.1
6.3.4	Properties of Steel .....	6.3.6
	Physical Properties .....	6.3.6
	Mechanical Properties .....	6.3.7
	High Performance Steel.....	6.3.8
6.3.5	Anticipated Modes of Steel Deficiencies.....	6.3.9
	Corrosion .....	6.3.9
	Fatigue Cracking .....	6.3.10
	Overloads.....	6.3.12
	Collision Damage .....	6.3.12
	Heat Damage .....	6.3.13
	Coating Failures .....	6.3.13
6.3.6	Protective Systems .....	6.3.15
	Function of Protective Systems .....	6.3.15
	Paint.....	6.3.17
	Paint Layers .....	6.3.17
	Types of Paint .....	6.3.18
	Oil/alkyd Paint.....	6.3.18
	Vinyl Paint.....	6.3.18
	Epoxies .....	6.3.18
	Epoxy Mastics .....	6.3.19
	Urethanes.....	6.3.19
	Zinc-rich Primers.....	6.3.19
	Latex Paint.....	6.3.19
	Galvanic Action.....	6.3.19
	Metalizing .....	6.3.20
	Galvanizing.....	6.3.20
	Weathering Steel Patina .....	6.3.20
	Uses of Weathering Steel.....	6.3.20
	Protection of Suspension Cables and Stayed Cables.....	6.3.21
6.3.7	Inspection Methods for Steel .....	6.3.21
	Visual Examination .....	6.3.21
	Steel Members .....	6.3.21
	Protective Coatings .....	6.3.23

Weathering Steel.....	6.3.26
Color.....	6.3.26
Texture.....	6.3.29
Physical Examination.....	6.3.30
Steel Members.....	6.3.30
Protective Coatings.....	6.3.30
Mill Scale.....	6.3.31
Paint Adhesion.....	6.3.31
Paint Dry Film Thickness.....	6.3.31
Repainting.....	6.3.32
Weathering Steel Patina.....	6.3.32
Advanced Inspection Methods.....	6.3.33
6.3.8 Other Bridge Materials.....	6.3.33
Cast Iron.....	6.3.33
Properties of Cast Iron.....	6.3.34
Cast Iron Deficiencies.....	6.3.34
Wrought Iron.....	6.3.34
Properties of Wrought Iron.....	6.3.34
Wrought Iron Deficiencies.....	6.3.35
Aluminum.....	6.3.35
Properties of Aluminum.....	6.3.35
Aluminum Deficiencies.....	6.3.35

This page intentionally left blank.



Steel Description	Steel Designation		Years in Use
	American Society for Testing and Materials (ASTM)	American Association of State Highway and Transportation Officials (AASHTO)	
Structural Carbon Steel	A7	M94	1900-1967
Structural Nickel Steel	A8	M96	1912-1962
Structural Steel	A36 (A709 Grade 36)	M183 (M270 Grade 36)	1960-Present (1974-Present)
Structural Silicon Steel	A94	M95	1925-1965
Structural Steel	A140		1932-1933
Structural Rivet Steel	A141	M97	1932-1966
High-Strength Structural Rivet Steel	A195	M98	1936-1966
High-Strength Low-Alloy Structural Steel	A242	M161	1941-Present
Low and Intermediate Tensile Strength Carbon Steel Plates	A283		1946-Present
Low and Intermediate Tensile Strength Carbon-Silicon Steel Plates	A284		1946-Present
Steel Sheet Piling	A328	M202	1950-Present
Structural Steel for Welding	A373	M165	1954-1965
High-Strength Structural Steel	A440	M187	1959-1979
High-Strength Low-Alloy Structural Manganese Vanadium Steel	A441	M188	1954-1989
High-Yield-Strength, Quenched and Tempered Alloy Steel Plate (Suitable for Welding)	A514 (A709 Grade 100/100W)	M244 (M270 Grade 100/100W)	1964-Present (1974-Present)
Hi Strength Low-Alloy Columbium-Vanadium Steel of Structural Quality	A572 (A709 Grade 50)	M223 (M270 Grade 50)	1966-Present (1974-Present)
Hi-Strength Low-Alloy Structural Steel with 50 ksi Minimum Yield Point to 4 inches Thick	A588 (A709 Grade 50W)	M222 (M270 Grade 50W)	1968-Present (1974-Present)
High-Strength Low-Alloy Steel H-Piles and Sheet Piling	A690		1974-Present
Quenched and Tempered Low-Alloy Structural Steel Plate with 70 ksi Minimum Yield Strength to 4 inches Thick	A852 (A709 Grade 70W)	M313 (M270 Grade 70W)	1985-Present (1985-Present)
<b>Summary of Steel Designations (Primary Source: Beer and Johnston, <i>Mechanics of Materials</i>, New York: McGraw-Hill, 1981)</b>			
High Performance Steel	A709 (HPS 50W, HPS 70W, HPS 100W)	M270 (HPS 50W, HPS 70W, HPS 100W)	1996-Present

# Topic 6.3 Steel/Metal

## 6.3.1

### Introduction

Steel is a widely used construction material for bridges due to its strength, relative ductility, and reliability. It is found in a variety of members on a large number of bridges. Therefore, the bridge inspector needs to be familiar with the various properties and types of steel.

## 6.3.2

### Common Methods of Steel Member Fabrication

#### Rolled Shapes

Rolled beams are manufactured in structural rolling mills. The flanges and web are one piece of steel. Rolled beams in the past were generally available no deeper than 36 inches in depth but are now available from some mills as deep as 44 inches.

Rolled beams are generally “compact” sections which satisfy flange to web thickness ratios to prevent buckling.

Rolled beams generally will have bearing stiffeners but no intermediate stiffeners since they are compact. Although rolled beams may not incorporate intermediate stiffeners, they will have connection plates for diaphragms or cross-frames.

#### Built-Up Shapes

Plate girders are often specified when the design calls for members deeper than 36 or 44 inches.

Plate girders are built-up shapes composed of any combination of plates, bars, and rolled shapes. The term “built-up” describes the way the final shape is made.

Older fabricated multi-girders were constructed of riveted built-up members. Today’s fabricated multi-girders are constructed from welded members.

## 6.3.3

### Common Steel Shapes Used in Bridge Construction

Steel as a bridge construction material is available as wire, cable, plates, bars, rolled shapes, and built-up shapes. Typical areas of application for the various types of steel shapes are listed below:

- Wires are the most efficient form of steel for a tensile capacity per pound basis. Wires are typically used as prestressing strands or tendons in beams and girders (See Figure 6.3.1).
- Cables can be fabricated from steel wire rope, parallel wires or seven wire strands. Cable-stay and steel suspension bridges are primarily supported by steel cables (see Figure 6.3.2).
- Steel plates have a wide variety of uses. They are primarily used to construct built-up shapes (see Figures 6.3.3 and 6.3.4).

- Steel bars are generally placed in concrete to provide tensile reinforcement in the form of deformed round bars (see Figure 6.3.5). Steel bars can also be used as primary members such as eyebars in older trusses or arches (see Figure 6.3.6) or secondary tension members.
- Rolled shapes are used as structural beams and columns and are made by placing a block of steel through a series of rollers that transform the steel into the desired shape. These steel shapes are either hot rolled or cold rolled. The typical rolled shape is an “I” shape. The “I” shape comes in many sizes and weights (see Figure 6.3.7). Other rolled shapes are channel or “C” shapes, angles, and “T” shapes.
- Built-up shapes are also used as structural beams and columns but are composed of any combination of plates, bars, and rolled shapes. The term “built-up” describes the way the final shape is made. Built-up shapes are used when an individual rolled shape cannot carry the required load or when a unique shape is desired. Built-up shapes are riveted, bolted, or welded together. Common built-up shapes include I-girders, box girders, and truss members (see Figure 6.3.8).



**Figure 6.3.1** Prestressing Strands for a Box Beam



**Figure 6.3.2** Steel Cables with Close-up of Cable Cross-Section



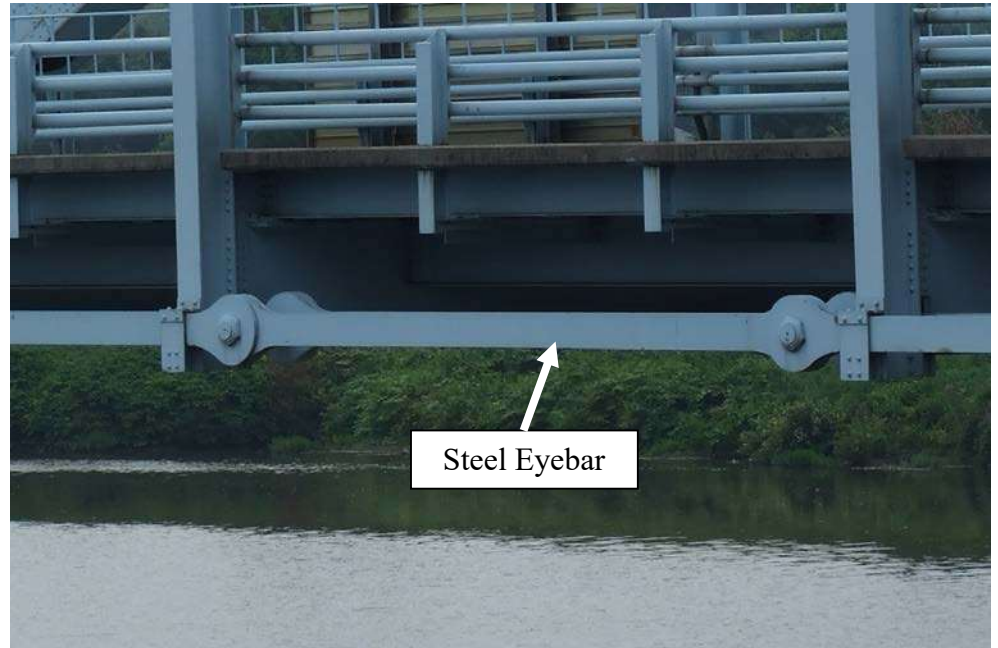
**Figure 6.3.3** Steel Plate Welded to Girder



**Figure 6.3.4** Welded I-Girder



**Figure 6.3.5** Steel Reinforcement Bars



**Figure 6.3.6** Steel Eyebar



**Figure 6.3.7** Rolled Beams



**Figure 6.3.8** Built-up Girder

## 6.3.4

---

### Properties of Steel

#### Physical Properties

When compared with iron, steel has greater strength characteristics, it is more elastic, and can withstand the effects of impact and vibration better.

Iron consists of small amounts of carbon. However, when the carbon content is between 0.1% and 2.1%, the material is classified as steel. Steel has a unit weight of about 490 pcf.

ASTM and AASHTO define the required properties for various steel types. ASTM classifies each type with an "A" designation, while AASHTO uses an "M" designation.

Low carbon steel, steel with carbon content less than approximately 0.3%, defines some of the most common steel types:

- A7 steel - the most widely used bridge steel up to about 1967; obsolete due to poor weldability characteristics
  - A373 steel - similar to A7 steel but has improved weldability characteristics due to controlled carbon content
  - A36 steel - first used in 1960 which features good weldability and improved strength and replaced A7 as the "workhorse" bridge steel; now specified as A709, Grade 36
  - A709 steel – the current overall umbrella specification used in bridge construction which was developed in 1974
- A709 steel covers carbon and high-strength alloy steel structural shapes,

plates and bars, and quenched and tempered alloy steel for structural plates intended for use in bridges. There are six grades available in four yield strength levels (36, 50, 70, and 100). The steel grade is equivalent to the yield strength in units of kips per square inch (ksi). Grades 36, 50, 50W, 70W, and 100/100W are also included in ASTM Specifications A36, A572, A588, A852, and A514, respectively. Grades 50W, 70W, and 100W have enhanced atmospheric corrosion resistance and are labeled with a "W" for weathering steel.

Structural nickel steel (A8) was used widely prior to the 1960's in bridge construction, but welding problems occurred due to relatively high carbon content.

Structural silicon steel (A94) was used extensively in riveted or bolted bridge structures prior to the development of low alloy steels in the 1950's. This steel also has poor weldability characteristics due to high carbon content.

Quenched and tempered alloy steel plate (A514) was developed primarily for use in welded bridge members.

High strength, low alloy steel is used where weight reduction is required, where increased durability is important, and where atmospheric corrosion resistance is desired; examples include:

- A441 steel - manganese vanadium steel
- A572 steel - columbium-vanadium steel (replaced by A441 in 1989)
- A588 - a "weathering steel," was developed to be left unpainted, which develops a protective oxide coating (patina) upon exposure to the atmosphere under proper design and service conditions (refer to Topic 6.3.6 for a further description of weathering steel)

These steels are also copper bearing, which provides increased resistance to atmospheric corrosion and a slight increase in strength.

In addition to the ASTM steel designations, the American Association of State Highway and Transportation Officials (AASHTO) also publishes its own steel designation (M270). For each ASTM steel designation, there is generally a corresponding AASHTO steel designation. For a summary of the various ASTM and AASHTO steel designations, refer to the table at the beginning of Topic 6.3.

### **Mechanical Properties**

Some of the mechanical properties of steel include:

- Strength - steel is isotropic and possesses great compressive and tensile strength, which varies widely with type of steel
- Elasticity - the modulus of elasticity is nearly independent of steel type and is commonly assigned as 29,000,000 psi
- Ductility - both the low carbon and low alloy steels normally used in bridge construction are quite ductile; however, brittleness may occur because of heat treatment, welding, or metal fatigue
- Fire resistance - steel is subject to a loss of strength when exposed to high



temperatures such as those resulting from fire (see Topic 6.3.5 – for specific temperature information)

- Corrosion resistance - unprotected carbon steel corrodes (i.e., rusts) readily; however, steel can be protected by coating, plating or adding weathering components to the alloy
- Weldability – today’s steel is weldable, but it is necessary to select a suitable welding procedure based on the chemistry of the steel

Fatigue - fatigue problems in steel members and connections can occur in bridges due to numerous live load stress cycles combined with poor weld or connection details

- Fracture toughness for mechanical property

### High Performance Steel

In 1996, a new steel type, High Performance Steel (HPS), was introduced to bridge construction (see Figure 6.3.9). Prior to the new steel designs, a set of “goal properties” was implemented and then testing took place to meet the goals. The first grade of HPS was A709 HPS 70W, which was produced by Thermo-Mechanical-Controlled Processing (TMCP). The new high performance steels exhibit enhanced weldability, fracture toughness, and corrosion resistance properties over the more common low carbon steels. Currently the HPS grades available are HPS 50W, HPS 70W, and HPS 100W and like low carbon steels, the “W” stands for weathering steel. Bridge girders may be constructed as ‘hybrid’ members (70 ksi flanges and 50 ksi webs). This results in a more shallow girder which helps with low clearance problems.



**Figure 6.3.9** High Performance Steel Bridge

### 6.3.5

## Anticipated Modes of Steel Deficiencies

### Corrosion

To properly inspect a steel bridge, the inspector will have to be able to recognize the various types of steel deficiencies and deterioration. The inspector will also have to understand the causes of the deficiencies and how to examine them. The most recognizable type of steel deficiency is corrosion (see Figure 6.3.10). Bridge inspectors will have to be familiar with corrosion since it can lead to a substantial section reduction resulting in decreased member capacity. Corrosion is the primary cause of section loss in steel members and is most commonly caused by the wet-dry cycles of exposed steel. When deicing chemicals are present, the effect of corrosion is accelerated.



**Figure 6.3.10** Steel Corrosion and Complete Section Loss on Girder Webs

Some of the common types of corrosion include:

- Environmental corrosion - primarily affects metal in contact with soil or water and is caused by formation of a corrosion cell due to deicing chemical concentrations, moisture content, oxygen content, and accumulated foreign matter such as roadway debris and bird droppings
- Stray current corrosion - caused by electric railways, railway signal systems, cathodic protection systems for pipelines or foundation pilings, DC industrial generators, DC welding equipment, central power stations, and large substations
- Bacteriological corrosion - organisms found in swamps, bogs, heavy clay, stagnant waters, and contaminated waters can contribute to corrosion of

metals

- Stress corrosion - occurs when tensile forces expose an increased portion of the metal at the grain boundaries, leading to corrosion and ultimately fracture
- Fretting corrosion - takes place on closely fitted parts which are under vibration, such as machinery and metal fittings, and can be identified by pitting and a red deposit of iron oxide at the interface
- Pack rust – occurs between two mating surfaces of elements; an increase in volume of rust over the original steel will create localized distortion and possibly cracking
- Crevice corrosion – occurs between adjacent surfaces, but the rust may not expand

### Fatigue Cracking

Fatigue failure occurs at a stress level below the yield stress and is due to repeated loading. Fatigue cracking has occurred in several types of bridge structures around the nation (see Figure 6.3.11). This type of cracking can lead to sudden and catastrophic failure on certain bridge types. Therefore, the bridge inspector needs to know where to look and how to recognize early stages of fatigue crack development.



**Figure 6.3.11** Fatigue Crack

Some factors leading to the development of fatigue cracks are:

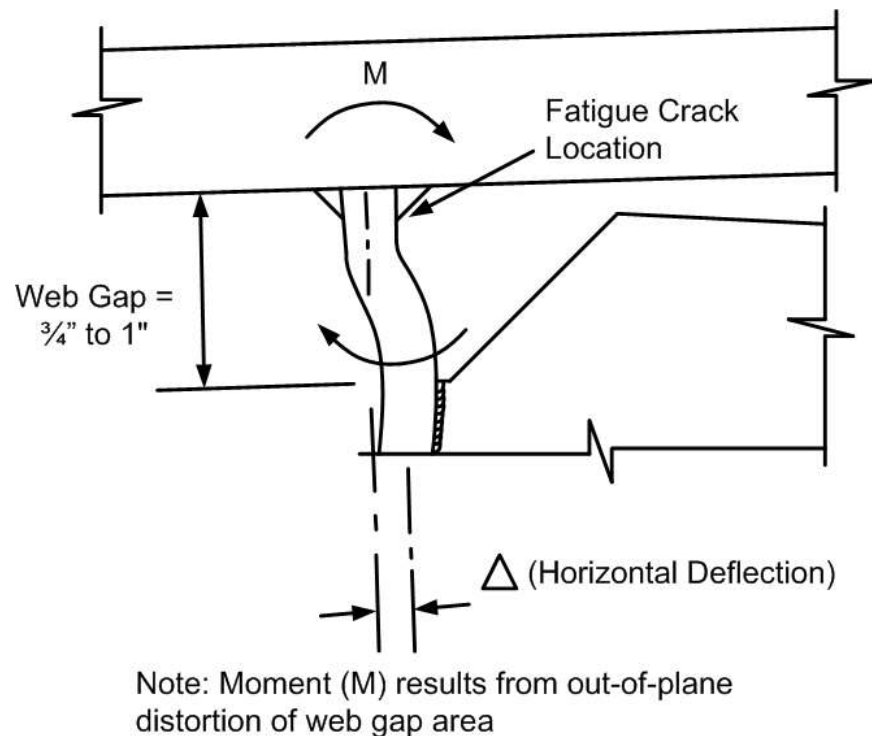
- Frequency of truck traffic
- Age or load history of the bridge

- Magnitude of stress range
- Type of detail
- Quality of the fabricated detail
- Material fracture toughness (base metal and weld metal)
- Weld quality
- Ambient temperature

There are two basic types of bending in bridge members: in-plane and out-of-plane. When in-plane bending occurs, the cross section of the member resists the load according to the design and undergoes nominal elastic deformation. Out-of-plane bending implies that the cross section of the member is loaded in a plane other than that for which it was designed and undergoes significant elastic deformation or distortion. More correctly, out-of-plane bending may be referred to as distortion induced fatigue. Out-of-plane distortion is common in beam webs where transverse members, such as floorbeams, connect and can lead to fatigue cracking (see Figure 6.3.12).

There is a distinction between fatigue that is caused from in-plane (as designed) bending and out-of-plane distortion.

Additional information about fatigue and fracture in steel bridges is presented in Topic 6.4.



**Figure 6.3.12** Distortion Induced Fatigue

## Overloads

Loads that exceed member or structure design are known as overloads. Steel is elastic (i.e., it returns to the original shape when a load is removed) up to a certain point, known as the yield point (see Topic 5.1). When yield occurs, steel will bend or elongate and remain distorted after the load has been removed. This type of permanent deformation of material beyond the elastic range is called plastic deformation. Plastic deformations due to overload conditions may be encountered in both tension and compression members.

The symptoms of plastic deformation in tension members are:

- Elongation
- Decrease in cross section, commonly called "necking down"

The symptoms of plastic deformation in compression members are:

- Buckling in the form of a single bow
- Buckling in the form of a double bow or "S" type, usually occurring where the section under compression is pinned or braced near the center point

An overload can lead to plastic deformation, as well as complete failure of the member and structure. This occurs when a tension member breaks or when a compression member exhibits buckling distortion at the point of failure.

## Collision Damage

Components and structural members of a bridge that is adjacent to a roadway or waterway traffic are susceptible to collision damage. Indications of collision damage include broken, dislocated or distorted members (see Figure 6.3.13).



**Figure 6.3.13** Collision Damage on a Steel Bridge

## Heat Damage

Steel members undergo serious deformation when exposed to extreme heat (see Figure 6.3.14). In addition to sagging, or elongation of the metal, intense heat often causes members to buckle and twist; rivets and bolts may fail at connection points. Buckling could be expected where the member is under compression, particularly in thin sections such as the web of a girder.



**Figure 6.3.14** Heat Damage

Temperatures affecting steel strength commonly used in bridges are as follows:

- 600°-1000°F - starts to affect strength
- Above 1000°F - major loss of strength

Once steel is subjected to heat, the yield strength and modulus of elasticity are relatively constant and can be reduced to approximately 90% of its value up to 600°F. Between 600°F and 1000°F, the yield strength will then further be reduced down to approximately 75% of its yield strength. The modulus of elasticity for steel will be reduced down to 75% at 1000°F. Temperatures above 1000°F will significantly reduce the strength properties of steel.

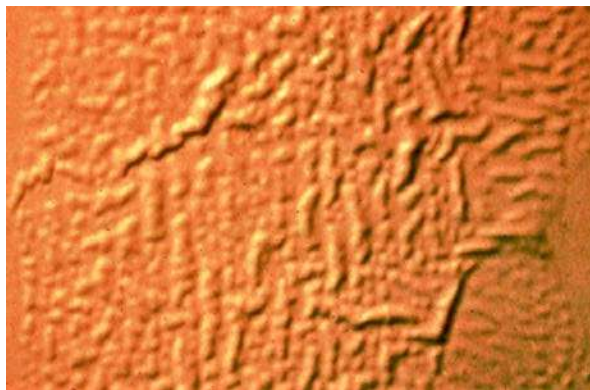
## Coating Failures

The following coating failures are common on steel:

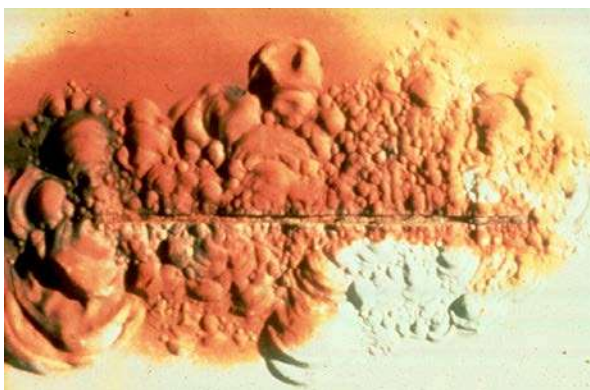
- Chalking, erosion, checking, cracking, and wrinkling caused by too much paint (see Figure 6.3.15), as described in ASTM D-3359.
- Blisters are caused by painting over surface contaminants such as: oil, grease, water, salt, or by solvent retention. Corrosion can occur under blisters.
- Undercutting occurs when surface rust advances under paint. It commonly occurs along scratches that expose the steel or along sharp edges (see Figure 6.3.16). The corrosion undermines intact paint, causing it to blister

and peel.

- Pinpoint rusting can occur at pinholes in the paint, which are tiny, deep holes in the paint, exposing the steel (see Figure 6.3.17). It can also be caused by thin paint coverage. In this case, the "peaks" of the roughened steel surface protrude through the paint and corrode.
- Microorganism failure is caused by bacteria or fungi attacking biodegradable coatings. Oil/alkyds are the most often affected.
- Alligatoring can be considered a widely spaced checking failure, caused by internal stresses set up within the surface of a coating during drying (see Figure 6.3.18). The stresses cause the surface of the coating to shrink more rapidly to a much greater extent than the body of the coating. This causes large surface checks that do not reach the steel substrate.
- Mudcracking can be considered a widely spaced cracking failure, where the breaks in the coating extend to the steel substrate, allowing rapid corrosion (see Figure 6.3.19). Mudcracking is often a phenomenon of inorganic zinc-rich primers, which have been applied too thick or are applied on a hot surface. Rapid curing causes the shrinkage, which yields the alligatoring, and ultimately, mudcracks.
- Bleeding occurs when soluble colored pigment from an undercoat penetrates the topcoat, causing discoloration.



**Figure 6.3.15** Paint Wrinkling



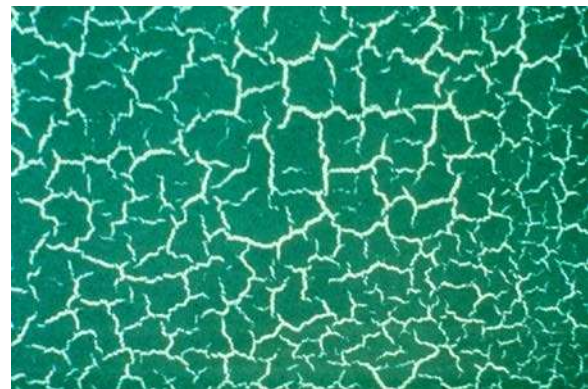
**Figure 6.3.16** Rust Undercutting at Scratched Area



**Figure 6.3.17** Pinpoint Rusting



**Figure 6.3.18** Paint Peeling from Steel Bridge Members



**Figure 6.3.19** Mudcracking Paint

### **6.3.6**

---

#### **Protective Systems**

##### **Function of Protective Systems**

Protective systems, when applied properly, provide active or passive protection against rust or corrosion by providing a barrier, a sacrificial anode (galvanic action) or both. Protective systems may be passive or active.

Passive systems include paint, metalizing or galvanizing through galvanic action, or weathering steel patina. These systems are self-functioning and operate through a



protective film that either isolates the base metal (paint and weathering steel) or accelerates corrosion of the coating, thereby slowing or stopping corrosion of the base metal (galvanic action).

Active systems include cathodic protection systems. These systems incorporate an external current source and artificial anode mesh or coating, together which reverses the current of the system and prevents electron loss of the steel or metal. Because corrosion only occurs at the electron-losing anode (steel or metal), the reversed current turns the steel or metal into a giant cathode, which does not corrode. The anode mesh or coating is also spared from corrosion, since the system utilizes artificially created electrons instead of electrons from the mesh or coating.

A thorough understanding of the steel corrosion process will help in the inspection of protective systems on bridge members.

Corrosion can be defined as a wearing away of metal by a chemical or electrochemical oxidizing process. Corrosion in metals is a form of oxidation caused by a flow of electricity from one part of the surface of one piece of metal to another part of the same piece. The result is the conversion of metallic iron to iron oxide. Once the corrosion process takes place, the steel member has a loss of section which results in a loss of structural capacity. Both conduction and soluble oxygen are necessary for the corrosion process to occur.

A conductive solution (water) or electrolyte must be present in order for current to flow. Corrosion occurs very slowly in distilled water, but much faster in salty water, because the presence of salt (notably sodium chloride) improves the ability of water to conduct electricity and contributes to the corrosion process. In the absence of chlorides, steel (iron) corrodes slowly in the presence of water. Water is both the medium in which corrosion normally occurs and provides the corrosion reaction. In addition, oxygen accelerates the corrosion process. Corrosion stops or proceeds at a reduced rate when access to water and oxygen is eliminated or limited. Water and oxygen are therefore essential for the corrosion process. For example, corrosion of steel does not occur in moisture-free air and is negligible when the relative humidity of the air is below 30% at normal or lower temperatures. The presence of chlorides in the water will accelerate corrosion by increasing the conductivity of the water.

The following are required to promote corrosion in steel:

- Oxygen
- An electrolyte to conduct current
- An area or region on a metallic surface with a negative charge (cathode)
- An area or region on the metallic surface with a positive charge (anode)

Exposure of steel to the atmosphere provides a plentiful supply of oxygen. The presence of oxygen can limit corrosion by the formation of corrosion product films that coat the surface and prevent water and oxygen from reaching the uncorroded steel. The presence of contaminants such as chlorides accelerates the corrosion rate on steel surfaces by disrupting the protective oxide film.

## Paint

Paint is the most common passive system coating used to protect steel bridges. Paint is composed of four basic compounds: pigments, resin (also called binder), solvents (also called thinners), and additives (such as thickeners and mildewcides). The pigments contribute such properties as inhibition of corrosion of the metal surface (e.g., zinc, zinc oxide, red lead, and zinc chromate), reinforcement of the dry paint film, stabilization against deficiency by sunlight, color, and hardness. Pigments are generally powders before being mixed into paint. The resin also remains in the dry-cured paint layer. It binds the pigment particles together and provides adhesion to the steel substrate and to other paint layers. Thus, the strength of the binder contributes to the useful life of the coating. Paint can be classified as inorganic or organic, depending on the resin (binder). Inorganic paint uses a water soluble silicate binder which reacts with water during paint curing. Most types of paint contain one of a variety of available organic binders. The organic binders cure (harden) by one or more of the following mechanisms:

- Evaporation of solvents
- Reaction with oxygen in the air (oxidation)
- Polymerization - two or more resin molecules combine to form a single more complex molecule. Components when mixed react chemically to form a solid, rigid, resistant coating film.
- Moisture cured - reaction between resin system and atmospheric moisture.

Solvents, which are liquids (such as water and mineral spirits), are included in paint to transport the pigment-binder combination to the substrate, to lower paint viscosity for easier application, to help the coating penetrate the surface, and to wet the substrate. Since the solvent is volatile, it eventually evaporates from the dry paint film. Additives are special purpose ingredients that give the product extra performance features. For example, mildewcides reduce mildew problems, and thickeners lengthen the drying time for application in hot weather. Polymerization - Two or more resin molecules combine to form a single more complex molecule. Components when mixed react chemically to form a solid, rigid, resistant coating film.

Paint used on steel bridges acts as a physical barrier to moisture, oxygen, and chlorides, all of which promote corrosion. While water and oxygen are important to corrosion, chlorides from deicing salts or seawater spray accelerate the corrosion process significantly.

### Paint Layers

Paint on steel is usually applied in up to three layers, or coats:

- Primer coat
- Intermediate coat
- Topcoat

The primer coat is in direct contact with the steel substrate. It is formulated to have good wetting and bonding properties and may or may not contain passivating (corrosion-inhibiting) pigments.

The intermediate coat is designed to strongly adhere to the primer. It provides increased thickness of the total coating system, abrasion and impact resistance, and a barrier to chemical attack.

The topcoat (also called the finish coat) is typically a tough, resilient layer, providing a seal to environmental attack, water, impact, and abrasion. It is also formulated for an aesthetic appearance.

### **Types of Paint**

A wide variety of paints are applied to steel bridges. All of them except some zinc-rich primers use an organic binder.

#### **Oil/alkyd Paint**

Oil/alkyd paints use an oil such as linseed oil and an alkyd resin as the binding agent. Alkyd resin is synthetically produced by reacting a drying oil acid with an alcohol. Alkyd paints are low cost, with good durability, flexibility, and gloss retention. They are also tough, with moderate heat and solvent resistance. They are not designed to be used in water immersion service or in alkaline environments.

A disadvantage of this paint type is the offensive odor during application. They are also slow drying, difficult to clean up, and have poor exterior exposure. Alkyd paints often contain lead pigments, which are known to cause numerous health problems. The removal and disposal of lead-based paints is a heavily regulated activity in all states and can make maintenance activities very costly.

#### **Vinyl Paint**

Vinyl paints are based on various vinyl polymer binding agents dissolved in a strong solvent. These paints cure by solvent evaporation. Vinyls have excellent chemical, water, salt, acid, and alkali resistance, good gloss retention, and are applicable at low temperatures. Conversely, their disadvantages include poor heat and solvent resistance, and poor adhesion. Vinyls are usually not used with other types of paint in a paint system. Vinyl coatings can be formulated to serve as primer, intermediate, and topcoat in paint systems.

#### **Epoxies**

Epoxies utilize an epoxy polymer binder, which forms a tough, resilient film upon drying and curing. Drying is by solvent evaporation, while curing entails a chemical reaction between the coating components. Epoxy coatings have excellent atmospheric exposure characteristics, as well as resistance to chemicals and water. They are often used as the intermediate coat in a three-layer paint system. There are also two- and three-layer systems, which use only epoxies. One disadvantage of epoxies is that they chalk when exposed to sunlight. This chalking should be removed prior to top coating with another layer of epoxy or another material. If not removed, the chalking will compromise subsequent adhesion.

### Epoxy Mastics

Epoxy mastics are heavy, high solid content epoxy paints, often formulated with flaking aluminum pigment. The mastics are useful in applications where a heavy paint layer is required in one application. They can be formulated with wetting and penetrating agents, which permit application on minimally prepared steel surfaces.

### Urethanes

Urethanes are commonly used as the topcoat layer. They provide excellent sunlight resistance, hardness, flexibility (i.e., resistance to cracking), gloss retention, and resistance to water, harmful chemicals, and abrasion. All-urethane systems are also available which utilize urethane paints as primer, intermediate, and topcoat.

### Zinc-rich Primers

Zinc-rich primers contain finely divided zinc powder and either an organic or inorganic binder. They protect the steel substrate by galvanic action, wherein the metallic zinc corrodes in preference to the steel. The materials have excellent adhesion and resist rust undercutting when applied over a properly prepared surface. The zinc-rich primers should be well mixed prior to application, or some coated areas will be deficient in zinc, lowering the substrate protection.

### Latex Paint

Latex paint consists of a resin emulsion. The term covers a wide range of materials, each formulated for a different application. Latex on steel has excellent flexibility (allowing it to expand and contract with the steel as the temperature changes) and color retention, with good adhesion, hardness, and resistance to chemicals. Latex paint has low odor, faster drying time, and easier clean up.

Less durable than some other coatings and less flexibility in application temperature tolerances.

It is important to document the existing paint system on a bridge. The paint type may be shown on the bridge drawings or specifications. Some agencies list the paint type and application date on the bridge. Once the existing paint is determined, a compatible paint for any required maintenance can be chosen to provide long lasting results.

## **Galvanic Action**

The term "galvanic action" is generally restricted to the changes in normal corrosion behavior that result from the current generated when one metal is in contact with a different one. The two metals are in a corrosive solution when one metal may become an anode when it contacts a dissimilar metal. In such a "galvanic couple," the corrosion of one of the metals (e.g., zinc) will be accelerated, and the corrosion of the other (e.g., steel) will be reduced or possibly stopped. Galvanized coatings on highway guardrails and zinc-rich paint on structural steel are examples of galvanic protection using such a sacrificial (zinc) anode.

### **Metalizing**

Metalizing is a thermal spray application of a protective coating, typically zinc or zinc/aluminum. The coating can be applied in more extreme temperature ranges than most paints, by generally requires a higher degree of surface cleanliness and irregular surface profile. The coating is generally top-coated with a sealer to provide longer protection.

### **Galvanizing**

Galvanizing is a technique of coating metal generally accomplished by hot-dipping the metal. The coating is primary zinc, which then reacts with the environment to form a protective zinc oxide that prevents corrosion of the steel.

**Weathering Steel Patina** In the proper environments, weathering steel does not require painting but produces its own protective coating. When exposed to the atmosphere, weathering steel develops a protective patina oxide film, which seals and protects the steel from further corrosion. This oxide film is actually an intended layer of surface rust, which protects the member from further corrosion and loss of material thickness.

Weathering steel was first used for bridges in 1964 in Michigan. Since then, thousands of bridges have been constructed of weathering steel in the United States. The early successes of weathering steel in bridges led to the use of this steel in locations where the steel could not attain a protective oxide layer and where corrosion progressed beyond the intended layer of surface rust. Therefore, it is important for the inspector to distinguish between the protective layer of rust and advanced corrosion that can lead to section loss. It is also important to note that fatigue cracks can initiate in rust pitted areas of weathering steel.

The frequency of surface wetting and drying cycles determines the oxide film's texture and protective nature. The wetting cycle includes the accumulation of moisture from rainfall, dew, humidity, and fog, in addition to the spray of water from traffic. The drying cycle involves drying by sun and wind. Alternate cycles of wetting and drying are essential to the formation of the protective oxide coating. The protective film will not form if weathering steels remain wet for long periods of time.

It is common to find coating systems applied to the ends of weathering steel members near expansion joints and over substructure units. These systems minimize staining that may be associated with weathering steel.

### **Uses of Weathering Steel**

Weathering steels may be unsuitable in the following environments:

- Areas with frequent high rainfall, high humidity, or persistent fog
- Marine coastal areas where the salt-laden air may deposit salt on the steel, which leads to moisture retention and corrosion
- Industrial areas where chemical fumes may drift directly onto the steel and cause corrosion

- Areas subject to “acid rain” which has a sulfuric acid component

The location and geometrics of a bridge also influence performance of weathering steel. Locations where weathering steel may be unsuitable include:

- Tunnel-like situations which permit concentrated salt-laden road sprays, to accumulate on the superstructure caused by high-speed traffic passing under a low clearance bridge
- Low level water crossings where insufficient clearance over bodies of water exists so that spray and condensation of water vapor result in prolonged periods of wetness

### **Protection of Suspension Cables and Stayed Cables**

Suspension cables of steel suspension bridges are particularly difficult to protect from corrosion. One method is to wrap the cables with a neoprene elastomeric cable wrap system or with a glass-fabric-reinforced plastic shell. In some cases, the elastomeric cable wrap has retained water and accelerated corrosion. Another method is to pour or inject paints into the spaces between the cable strands. Commonly, inhibitive pigments, such as zinc oxide, in an oil medium are used. Red lead pigment was commonly used in the past. Lead constitutes a significant health hazard, and care should be exercised care when inspecting cables. Do not inhale or ingest old paint. The paint on the exterior surface of a suspension cable dries, but the paint on the interior, surrounding individual strands, stays in the liquid, uncured state for years. The exterior of the cable is often topcoated with a different paint, such as an aluminum pigmented oil-based paint. Another option to protect suspension cables is to wrap tightly with small diameter wires. This allows the cable to “breathe” while still providing a protective cover.

A newer technique used to resist the corrosion process of suspension cables is forced air dehumidification. On larger structures (such as the Kobe Bridge in Japan and the Ben Franklin Bridge in Pennsylvania), dry air is passed through the cables, which does not allow the steel to be exposed to moisture. For this protection system to work, the relative humidity of the forced air should be less than approximately 40%.

### **6.3.7**

#### **Inspection Methods for Steel**

There are three basic methods used to inspect a steel member. Depending on the type of inspection, the inspector may be required to use only one individual method or all methods. They include:

- Visual
- Physical
- Advanced inspection methods

#### **Visual Examination**

##### **Steel Members**

Inspect steel members for corrosion, section loss, buckling, and cracking.

In the inspection records, identify the location of Fracture Critical Members (FCMs) and describe the FCM inspection frequency and procedures. Inspect FCMs

according to the AASHTO *Manual for Bridge Evaluation*. See Topic 6.4 for detailed description of inspection procedures of fracture critical members.

Some common steel bridge inspection locations and signs of distress include:

- Bent or deficiency members - determine the type of deficiency (e.g., collision, overload, or fire), inspect for proper alignment, and check for cracks, tears, and gouges near the deficiency location
- Corrosion, which could reduce structural capacity through a decrease in member section and make the member less resistant to both repetitive and static stress conditions; since rust continually flakes off of a member, the severity of corrosion cannot always be determined by the amount of rust; therefore, corroded members must be examined by physical as well as visual means (see Figure 6.3.20)
- Fatigue prone details - fatigue cracks may occur at certain locations on a bridge, and certain inspection procedures need to be followed when fatigue cracks are observed (see Figure 6.3.21 and Topic 6.4 for additional information about fatigue cracks)
- Other stress-related cracks - determine the length, size, and location of the crack
- Points on the structure where a discontinuity or restraint is introduced
- Loose members which could force the member or other members to carry unequal or excessive stress
- Damaged members, regardless of damage magnitude, which are misaligned, bent, or torn
- Problematic details: welded or mechanical connections; look for cracks in the paint, cracks in the steel
- Repairs that show indiscriminate welding or cutting procedures
- Areas of excessive vibrations or twisting

Inspection procedures for observed in-plane fatigue cracks:

- Report the fatigue crack immediately
- Determine the visual ends of the crack
- Examine other identical details on the bridge for cracks
- If a suspect area is located, a more detailed advanced inspection method may be required (see Topic 15.3).



**Figure 6.3.20** Corrosion of Steel



**Figure 6.3.21** Fatigue Crack

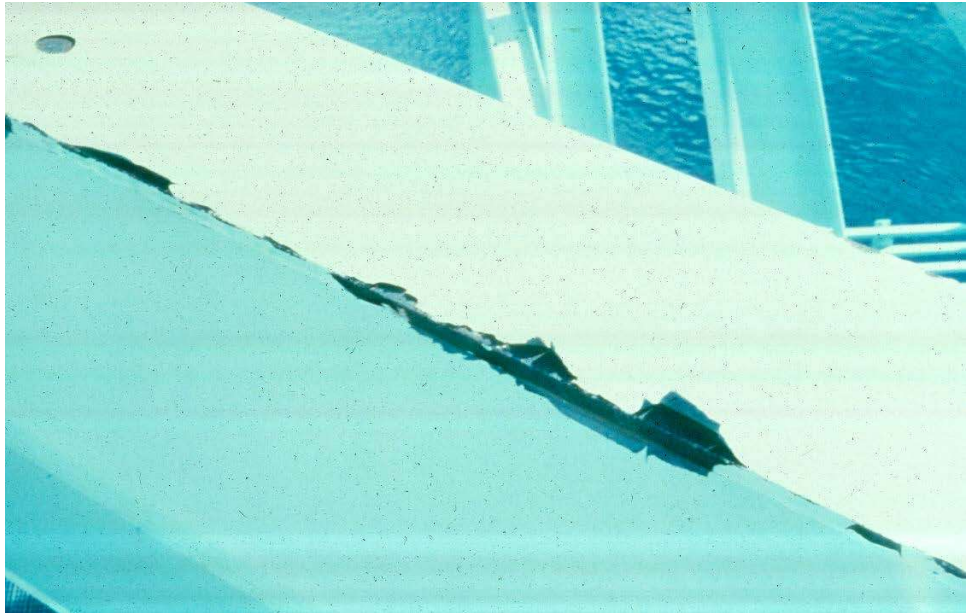
### **Protective Coatings**

Rust typically starts in a few characteristic places such as horizontal surfaces where water, dirt and debris accumulate, then spreads to larger areas.

Examine sharp edges and square corners of structural members (see Figure 6.3.22). Paint is generally thinner at sharp edges and corners than at rounded edges and corners or flat surfaces. Rusting starts at sharp edges, then undercuts intact paint as it spreads away from the edge. Inside square corners often receive an extra thick layer of paint due to double or triple passes made over them. Extra thick layers are prone to paint cracking, exposing the steel. It is difficult to completely remove dirt



and spent blast cleaning abrasive from inside corners. Painting over this foreign material results in early peeling and corrosion.



**Figure 6.3.22** Paint Failure on Edge of Steel Truss Member

Examine all areas that retain moisture and salt. Check under scuppers and beneath downspouts and under expansion joints. Check horizontal surfaces under the edge of bridge decks and under expansion dams, where roadway deicing salt runoff collects (see Figure 6.3.23). Examine the top surfaces of girder bottom flanges.

Inspect inaccessible or hard-to-reach areas that may have been missed during painting. A flashlight and inspection mirror may be needed to visually inspect these areas. Examine the inside surfaces of lattice girders and beams. Examine all horizontal surfaces. These areas trap water and are susceptible to paint failure, corrosion, and section loss.

Inspect around bolts, rivets, and pins (see Figure 6.3.24). Rust detected around the heads may indicate corrosion along the entire length of the bolt, rivet, or pin, causing reduced structural integrity.

Examine roadway splash or spray zones, where debris and corrosive deicing salt-laden water are directly deposited on painted members by passing traffic (see Figure 6.3.25). On through-truss bridges, this includes some bracing members above the roadway.

Examine areas exposed to wind and rain, seawater spray, and other adverse weather conditions.



**Figure 6.3.23** Water and Salt Runoff Near Expansion Joint



**Figure 6.3.24** Corroding Rivet Head



**Figure 6.3.25** Roadway Spray Zone Deficiency

### **Weathering Steel**

It is particularly important for weathering steel to be inspected in the following locations:

- Where water ponds or the steel remains damp for long periods of time due to rain, condensation, leaky joints, or traffic spray
- Where debris is likely to accumulate
- Where the steel is exposed to salts and atmospheric pollutants
- Near defective joints or drainage devices

### **Color**

The color of the surface of weathering steel is an indicator of the protective oxide film (see Figure 6.3.26). The color changes as the oxide film matures to a fully protective coating.

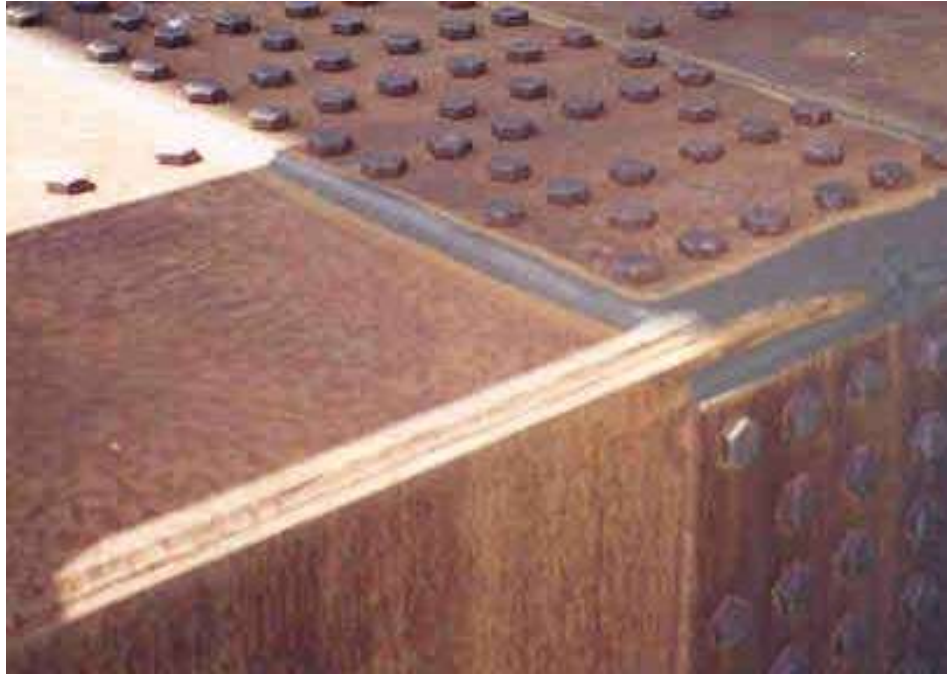
A yellow-orange, for new steel with initial exposure, is acceptable (see Figures 6.3.27 and 6.3.28). For bridges that have been in service for several years, purple brown color is acceptable (see Figure 6.3.29), while flaking steel or black color indicates the improper formation of the protective oxide film (see Figure 6.3.30).



**Figure 6.3.26** Color of Oxide Film is Critical in the Inspection of Weathering Steel; Dark Black Color in an Indication of Non-protective Oxide



**Figure 6.3.27** Yellow Orange – Early Development of the Oxide Film (Patina)



**Figure 6.3.28** Light Brown – Early Development of the Oxide Film (Patina)



**Figure 6.3.29** Chocolate Brown to Purple Brown - Fully Developed Oxide Film



**Figure 6.3.30** Black – Non-protective Oxide

An area of steel, which is a different color than the surrounding steel indicates a potential problem. The discolored area should be investigated to determine the cause of the discoloration. Color photographs are an ideal way to record the changing condition of the weathering steel over time. A color coupon may be included in each photograph to enable comparison.

#### Texture

The texture of the oxide film also indicates the degree of protection of the film. An inspection of the surface by tapping with a hammer and vigorously brushing the surface with a wire brush determines the adhesion of the oxide film to the steel substrate. Surfaces, which have granules, flakes, or laminar sheets are examples of non-adhesion. Figure 6.3.31 presents a correlation between the texture of the weathering steel and the degree of protection.

Appearance	Degree of Protection
Tightly adhered, capable of withstanding hammering or vigorous wire brushing	Protective oxide
Dusty	Early stages of exposure; should change after few years
Granular	Possible indication of problem, depending on length of exposure and location of member
Small flakes, 1/4 inch in diameter	Initial indication of non-protective oxide
Large flakes, 1/2 inch in diameter or greater	Non-protective oxide
Laminar sheets or nodules	Non-protective oxide, severe conditions

**Figure 6.3.31** Correlation Between Weathering Steel Texture and Condition

**Physical Examination**

**Steel Members**

Once the deficiencies are identified visually, physical methods are used to verify the extent of the deficiency. For steel members, the main physical inspection methods involve the measurement of deficiencies identified visually. An inspection hammer or wire brush is used to remove loose paint or rust flakes so accurate measurements of remaining section can be made. During the removal process, personal protective measurements are taken to ensure the inspector is protected against exposure to potentially hazardous materials. Excessive hammering, brushing or grinding may close surface cracks and make the cracks difficult to find. Corrosion causes in loss of member material. This loss of cross section due to corrosion is known as section loss. Section loss may be measured using a straight edge and a tape measure. However, a more exact method of measurement, such as calipers or an ultrasonic thickness gauge (D-meter), may be used to measure the remaining section of steel. Corrosion products need to be removed to obtain more accurate measurements.

Bridge member dimensions can be field measured and recorded to verify the accuracy of bridge member dimensions shown in plans or sketches. If incorrect member sizes are reported, the load rating analysis for safe load capacity of the bridge will be inaccurate.

**Protective Coatings**

The degree of coating failure can be assessed during the inspection. There are a variety of proprietary methods which use a set of photographic standards to evaluate and categorize the degree and extent of coating failure. A simple method entails evaluation of painted surfaces in accordance with the Society for Protective Coatings Guide to Visual Standard Number 2 (SSPC-Vis 2) “Standard Method for

Evaluating Degree of Rusting on Painted Steel Surfaces". Vis 2 is a pictorial standard for evaluating the degree of rusting on painted steel surfaces. Other visual comparison manuals can also be used to evaluate coating defects.

### Mill Scale

Incomplete removal of mill scale can provide a starting point for corrosion. When mill scale cracks, it allows moisture and oxygen to reach the steel substrate. Mill scale accelerates corrosion of the substrate because of its electrochemical properties. To check for mill scale corrosion during a paint inspection, use a knife to remove a small patch of paint in random areas. Inspect the exposed surface for mill scale, either intact or rusted. Probe with a knife or other sharp object at weld spatter to check for rusting. Re-coat areas where paint is removed.

Invisible microscopic chloride deposits from deicing chemicals or seawater spray may permeate a corroding steel surface. Painting over a partially cleaned chloride-contaminated surface simply seals in the contaminant. Salt deposits draw moisture through the paint by osmosis, and corrosion will continue.

### Paint Adhesion

Paint can undergo adhesion failure between paint layers or between the primer and steel. Some bridge painting contracts specify minimum acceptable paint adhesion strength for new paint. Over time, however, adhesion strength may degrade as the paint weathers and is affected by sunlight, or as rusting occurs under the paint.

The simplest test of adhesion is to probe under paint with the point of a knife. A more quantitative evaluation is performed by a tape test, as described in Topic 6.1. The tape test is still qualitative since there is not an actual measurement of adhesion (psi) such as with a pull-off test.

### Paint Dry Film Thickness

There are a variety of instruments to measure the dry film thickness of paint applied to steel. Accuracy ranges from 10% +/- to 15% +/-, and they fall into three classes:

- Magnetic pull-off
- Fixed probe
- Destructive test

The magnetic pull-off dry film thickness gages use the attractive force between a magnet and the steel substrate to determine the paint thickness. The thicker the paint, the lower the magnetic force. These instruments must be calibrated prior to and during use with plastic shims of known thickness, or with ferrous plates coated with a non-ferrous layer.

The fixed probe gages also use a magnet. Measurement of paint thickness is done by an electrical measurement of the interaction of the probe's magnetic field with the steel rather than by the force to move the magnet. They are normally



calibrated with plastic shims. Neither the magnetic pull-off nor fixed probe gages can be used closer than one inch to edges, as this will distort the reading. The Society for Protective Coatings Paint Application Standard Number 2 (SSPC-PA2) "Measurement of Dry Paint Thickness With Magnetic Gages" provides a detailed description of how to calibrate and take measurements using magnetic gages.

Another method for measuring dry film thickness using the gage described in Topic 6.1. An advantage of this method is that it can be used close to edges. While the magnetic gages measure the combined thickness of all paint layers, the instrument measures each layer individually. Limitations of the destructive test are that only coatings up to 50 mils thick can be measured and multiple layers of the same color cannot be easily distinguished.

### Repainting

If the coating is to be repainted, the type of in-place paint must be known, since different type paints may not adhere to each other. Methods described in Topic 6.1 can be used to determine the type of in-service paint.

### Weathering Steel Patina

Weathering steel with any of the following degree of protection should be inspected:

- Laminar texture of steel surface, such as slab rust or thin and fragile sheets of rust
- Granular and flaky rust texture of steel surface
- A very coarse texture
- Large granular (1/8 inch in diameter) texture
- Flakes (1/2 inch in diameter)
- Surface rubs off by hand or wire brush revealing a black substrate
- Surface is typically covered with deep pits

If such conditions are observed, the following steps may be taken to determine the adequacy of the oxide film:

- Scrape the surface of the steel to the bare metal
- Check to determine the extent of pitting
- Measure the remaining section thickness with calipers or an ultrasonic thickness gauge

It is important to set a benchmark at the point where the metal thickness measurement is taken so that any metal loss may be monitored with future measurements. Benchmarks are important since steel rolled sections and steel plates often vary within acceptable tolerances in thickness from the nominal thickness values.

Data obtained from the inspection will include visual observations of the steel

(e.g., color, texture, and flaking), physical measurements with a thickness gauge, and observation of environmental conditions.

### **Advanced Inspection Methods**

In addition, several advanced methods are available for steel inspection. Nondestructive methods, described in Topic 15.3.2, include:

- Acoustic emissions testing
- Corrosion sensors
- Smart coatings
- Dye penetrant
- Magnetic particle
- Radiography testing
- Computed tomography
- Robotic inspection
- Ultrasonic testing
- Eddy current
- Electrochemical fatigue sensor (EFS) (detects fatigue growth)
- Magnetic flux leakage (external PT tendons and stay cables)
- Laser vibrometer (for stay cable vibration measurement and cable force determination)

Other methods for determining material properties described in Topic 15.3.3, include:

- Brinell hardness test
- Charpy impact test
- Chemical analysis
- Tensile strength test

## **6.3.8**

---

### **Other Bridge Materials**

#### **Cast Iron**

Iron is an elemental metal smelted from iron ore. Iron is easily fractured by shocks and has low tensile strength due to a large percentage of free carbon and slag. Consequently, it is basically a poor bridge construction material and is not used in new bridge construction today. It may, however, be found in older bridges.

Cast iron is gray in color due to the presence of tiny flake-like particles of graphite (carbon) on the surface. It has a unit weight of approximately 450 pcf.

### **Properties of Cast Iron**

Some of the mechanical properties of cast iron include:

- Strength - tensile strength varies from 25,000 psi to 50,000 psi, while compressive strength varies from 65,000 psi to 150,000 psi
- Elasticity - cast iron has an elastic modulus of 13,000,000 psi to 30,000,000 psi: elasticity increases with a decrease in carbon content
- Workability - cast iron possesses good machinability, and casting is relatively easy and inexpensive
- Weldability - cast iron cannot be effectively welded due to its high free carbon content
- Corrosion resistance - cast iron is generally more corrosion resistant than the other ferrous metals
- Brittleness - cast iron is very brittle and prone to fatigue-related failure when subjected to cyclical stresses

### **Cast Iron Deficiencies**

The primary forms of deficiency in cast iron are similar to those in steel.

## **Wrought Iron**

When iron is mechanically worked or rolled into a specific shape, it is classified as wrought iron. This process results in slag inclusions that are embedded between the microscopic grains of iron. It also results in a fibrous material with properties in the worked direction similar to steel. Wrought iron is no longer made in the United States. However, wrought iron members still exist on some older bridges, and were well-suited for use in the early suspension bridges.

### **Properties of Wrought Iron**

Some of the mechanical properties of wrought iron include:

- Strength - wrought iron is anisotropic (i.e., its strength varies with the orientation of its grain) due to the presence of slag inclusions; compressive strength is about 35,000 psi, while tensile strength varies between 36,000 psi and 50,000 psi
- Elasticity - modulus of elasticity ranges from 24,000,000 psi to 29,000,000 psi, nearly as high as steel
- Impact resistance - wrought iron is tough and is noted for impact and shock resistance
- Workability - wrought iron possesses good machinability
- Weldability - wrought iron can be welded, but care should be exercised when welding the metal of an existing bridge
- Corrosion resistance - the fibrous nature of wrought iron produces a tight rust which is less likely to progress to flaking and scaling than is rust on carbon steel

- Ductility - wrought iron is generally ductile; reworking the wrought iron causes a finer and more thread-like distribution of the slag, thereby increasing ductility

### **Wrought Iron Deficiencies**

The primary forms of deficiency in wrought iron are similar to those in steel.

## **Aluminum**

Aluminum is widely used for signs, light standards, railings, and sign structures. Aluminum is seldom used as a primary material in the construction of vehicular bridges. However, aluminum has been used to replace iron or steel members for rehabilitation projects. Aluminum weighs less than steel and may allow greater live loads on the rehabilitated structures.

### **Properties of Aluminum**

The properties of aluminum are generally similar to those of steel. However, a few notable differences exist:

- Weight - aluminum alloy has a unit weight of about 175 pcf
- Strength - aluminum is not as strong as steel, but alloying can increase its strength to that of steel
- Corrosion resistance - aluminum is highly resistant to atmospheric corrosion
- Workability - aluminum is easily fabricated, but welding of aluminum requires special procedures
- Durability - aluminum is durable
- Expense - aluminum is more expensive than steel

### **Aluminum Deficiencies**

The primary forms of deficiency in aluminum are:

- Fatigue cracking - the combination of high stresses and vibration caused by cyclic loading
- Pitting - aluminum can pit slightly, but this condition rarely becomes serious
- Corrosion - corrosion in direct contact with fresh concrete if not coated or otherwise protected. Aluminum reacts principally with alkali hydroxides from cement. Aluminum in contact with plain concrete can corrode, and the situation is worse if the concrete contains calcium chloride as an admixture or if the aluminum is in contact with dissimilar metal.

This page left intentionally blank

# Table of Contents

## Chapter 6 Bridge Materials

---

6.4	Fatigue and Fracture in Steel .....	6.4.1
6.4.1	Introduction .....	6.4.1
	Fracture Critical Member .....	6.4.3
	Fatigue .....	6.4.3
	Reviewing Member Forces .....	6.4.3
	Redundancy.....	6.4.3
	Load Path Redundancy.....	6.4.4
	Structural Redundancy .....	6.4.5
	Internal Redundancy.....	6.4.6
	Non-redundant Configuration.....	6.4.7
6.4.2	Failure Mechanics.....	6.4.8
	Crack Initiation .....	6.4.8
	Crack Propagation.....	6.4.8
	Fracture .....	6.4.8
	Fatigue Life.....	6.4.9
	Types of Fractures.....	6.4.9
	Factors that Determine Fracture Behavior .....	6.4.10
	Fracture Toughness .....	6.4.11
6.4.3	Factors Affecting Fatigue Crack Initiation.....	6.4.11
	Welds .....	6.4.12
	Material Deficiencies .....	6.4.16
	Fabrication Flaws.....	6.4.17
	Transportation and Erection Flaws .....	6.4.24
	In-Service Flaws .....	6.4.24
6.4.4	Factors Affecting Fatigue Crack Propagation .....	6.4.25
	Stress Range.....	6.4.26
	Number of Cycles .....	6.4.26
	Type of Details.....	6.4.26
	Flange Crack Failure Process .....	6.4.27
	Web Crack Failure Process .....	6.4.31
6.4.5	AASHTO Detail Categories for Load-Induced Fatigue .....	6.4.33
6.4.6	Fracture Critical Bridge Types .....	6.4.43
6.4.7	Fracture Criticality.....	6.4.43
	Details and Deficiencies.....	6.4.44
6.4.8	Inspection Methods and Locations .....	6.4.46
	Methods.....	6.4.46
	Visual.....	6.4.46
	Physical.....	6.4.46

	Advanced Inspection Methods .....	6.4.47
	Inspection of Details.....	6.4.47
	Recordkeeping and Documentation.....	6.4.47
	Recommendations .....	6.4.48
	Locations.....	6.4.49
	Problematic Details .....	6.4.49
	Triaxial Constraint .....	6.4.49
	Intersecting Welds.....	6.4.50
	Cover Plates .....	6.4.51
	Cantilevered-Suspended Span.....	6.4.52
	Insert Plates .....	6.4.53
	Field Welds: Patch and Splice Plates .....	6.4.54
	Intermittent Welds.....	6.4.55
	Out-of-Plane Bending .....	6.4.56
	Pin and Hanger Assemblies .....	6.4.62
	Back-Up Bars.....	6.4.62
	Mechanical Fasteners and Tack Welds.....	6.4.63
	Miscellaneous Connections.....	6.4.63
	Flange Terminations.....	6.4.64
	Coped Flanges .....	6.4.65
	Blocked Flanges .....	6.4.66
	Crack Orientation .....	6.4.66
	Crack Perpendicular to Primary Stress .....	6.4.66
	Crack Parallel to Primary Stress .....	6.4.66
	Corrosion Areas.....	6.4.67
	Nick and Gouges .....	6.4.67
6.49.	Evaluation .....	6.4.67
	NBI Rating Guidelines and Element Level Condition State	
	Assessment .....	6.4.67

# Topic 6.4 Fatigue and Fracture in Steel

## 6.4.1

### Introduction

Since the 1960's, many steel bridges have developed fatigue induced cracks. Although these localized failures have been extensive, only a few U.S. bridges have actually collapsed as a result of steel fatigue fractures. These collapses have helped shape the National Bridge Inspection Program.

The first collapse was the Silver Bridge over the Ohio River at Point Pleasant, West Virginia on December 15, 1967. This structure was an eyebar chain suspension bridge with a 700-foot main span that collapsed without warning and forty-six people died (see Figure 6.4.1). The collapse was due to stress corrosion and corrosion fatigue that allowed a minute crack, formed during casting of an eye-bar, to grow. The two contributing factors, over the years continued to weaken the eye-bar. Stress corrosion cracking is the formation of brittle cracks in a normally sound material through the simultaneous action of a tensile stress and a corrosive environment. Corrosion fatigue occurs as a result of the combined action of a cyclic stress and a corrosive environment. The bridge's eye-bars were linked together in pairs like a chain. A huge pin passed through the eye and linked each piece to the next. The heat-treated carbon steel eye-bar broke, placing undue stress on the other members of the bridge. The remaining steel frame buckled and fell due to the newly concentrated stresses.



**Figure 6.4.1** Silver Bridge Collapse

The second collapse occurred on June 28, 1983, when a suspended two-girder span carrying I-95 across the Mianus River in Greenwich, Connecticut failed (see Figure 6.4.2). The pin and hanger assembly failed at one location on one of the two girders. The forces were redistributed and caused an overstress that led to the bridge collapse.





**Figure 6.4.2** Mianus River Bridge Collapse

On August 1, 2007, the I-35W Mississippi River Bridge in Minneapolis, Minnesota collapsed. The cause of this deck truss collapse was due to a failed gusset plate (see Figure 6.4.3).



**Figure 6.4.3** I-35W Mississippi River Bridge Collapse

The above catastrophes resulted due to a failure of a fracture critical member. For bridge inspectors, understanding the causes of the common member failure modes is important. This understanding permits the inspector to use more time evaluating problematic areas of a bridge and less time on other portions of the bridge.

When inspecting steel bridges, the inspector identifies a fracture critical member

by sight or based on previous reports and drawings. The National Bridge Inspection Standards (NBIS) require that all fracture critical members on a bridge be identified, an inspection frequency be described and the inspection methods be listed prior to an inspection.

**Fracture Critical Member**

A fracture critical member (FCM) is a steel member in tension or with a tension element, whose failure probably causes a portion of or the entire bridge to collapse. Bridges that contain fracture critical members are considered fracture critical bridges.

**Fatigue**

Fatigue is the tendency of a member to fail at a stress level below its yield stress when subject to cyclical loading.

Fatigue is the primary cause of failure in fracture critical members. Describing the process by which a member fails when subjected to fatigue is called failure mechanics.

**Reviewing Member Forces**

Two criteria exist for a bridge member to be classified as fracture critical. The first criterion deals with the forces in the member. Members that are in tension or members that have fibers or elements that are in tension meet the first criterion. The five types of member forces are presented in Topic 5.1.3 and include:

- Axial tension – Acts along the longitudinal axis of a member and tends to “pull” the member apart
- Axial compression – Acts along the longitudinal axis of a member and tends to “push” the member together
- Shear – Equal but opposite transverse forces which tend to slide one section of a member past an adjacent section producing diagonal tension force oriented 45 degrees to the longitudinal axis
- Bending moment – Develops when an external load applied transversely to a bridge member causes it to bend and produces both compression and tension forces at different locations in the member and can be positive or negative
- Torsion – A type of shear force resulting from externally applied moments that tend to twist or rotate the member about its longitudinal axis producing diagonal tension present on all surfaces of the member

**Redundancy**

The second criterion for a bridge member to be classified as fracture critical is that its failure causes a total or partial collapse of the structure. Therefore, recognition and identification of a bridge’s degree of redundancy is crucial.

Redundancy is defined as a structural condition where there are more elements of support than are necessary for stability.

Redundancy means that if a member or element fail, the load previously carried by the failed member is redistributed to other members or elements. These other members have the capacity to temporarily carry additional load, and collapse of the structure may be avoided. On structures without redundancy, the redistribution of load may cause additional members to also fail, resulting in a partial or total collapse of the structure.

There are three basic types of redundancy to consider in bridge design:

- Load path redundancy
- Structural redundancy
- Internal redundancy

### **Load Path Redundancy**

Bridge designs that have three or more main load-carrying members or load paths between supports are considered load path redundant. If one member were to fail, the bridge load is redistributed to the other members, and bridge failure may not occur. An example of load path redundancy is a multi-girder bridge (see Figure 6.4.4).

Some agencies require that a bridge have four or more main load-carrying members to be considered load path redundant. Definitive determination of load path redundancy requires structural analysis with members eliminated in turn to determine resulting stresses in the remaining members.



**Figure 6.4.4** Load Path Redundant Multi-Girder Bridge

### Structural Redundancy

Bridge designs which provide continuity of load path from span to span are referred to as structurally redundant. Interior spans of a continuous span bridge designs are considered structurally redundant (see Figure 6.4.5). In the event of an interior member failure, loading from that span can be redistributed to the adjacent spans, and bridge failure may not occur.



**Figure 6.4.5** Structurally Redundant Continuous Span Bridge

Continuous spans are structurally redundant except for the end spans, where the development of a fracture effectively causes two hinges, one at the abutment and one at the fracture itself. This situation leads to structural instability.

The degree of structural redundancy can be determined through computer programs which model element failure. Some continuous truss bridges have structural redundancy, but this can only be determined through structural analysis.

### Internal Redundancy

Internal redundancy exists when a bridge member contains three or more elements that are mechanically fastened together so that multiple independent load paths are formed. Mechanical fasteners include rivets and bolts. Failure of one member element might not cause total failure of the member. Examples of internally redundant members are shown in Figures 6.4.6 and 6.4.7.

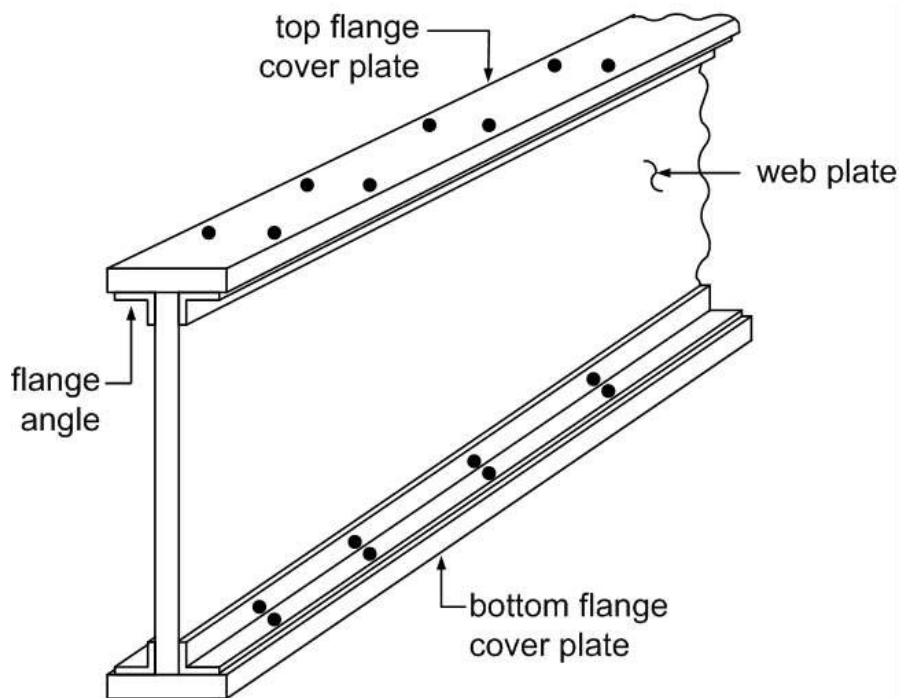


Figure 6.4.6 Internally Redundant Riveted I-Beam

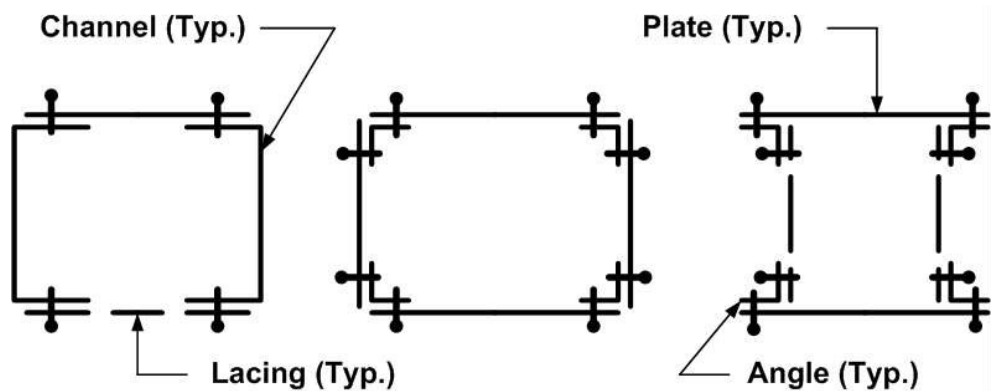


Figure 6.4.7 Internally Redundant Riveted Box Shapes

Internal redundancy of a member can be decreased or eliminated by repairs that involve welding. The welds provide paths for cracks to propagate from one element to another (see Figure 6.4.8).



**Figure 6.4.8** Patch Plate Welded on Riveted Girder Web along Flange Angle

#### **Non-redundant Configuration**

Bridge inspectors are concerned primarily with load path redundancy. Neglect structural and internal redundancy and classify all bridges with less than three load paths as nonredundant (see Figure 6.4.9). Non load path redundant bridge configurations in tension contain fracture critical members.

*AASHTO Standard Specifications for Highway Bridges*, 17th Edition, Section 10.3.1 states that main load-carrying components subjected to tensile stresses may be considered nonredundant load path members if failure of a single element could cause collapse.

*AASHTO LRFD Bridge Design Specifications*, 5<sup>th</sup> Edition, with 2010 Interim Revisions, Section 1.2, defines multiple load path structures as structures capable of supporting specified loads following loss of a main load-carrying component or connection. If a structure cannot support the specified loads following loss of a main load-carrying member, the consequence is “collapse” as defined in the *AASHTO LRFD Specifications*. Section 1.2 defines collapse as a major change in geometry of the bridge rendering it unfit for use.

*AASHTO LRFD Specifications*, Section 1.3.4, discusses redundancy. Main elements and components whose failure is expected to cause collapse of the bridge are designated as failure-critical and the associated structural system is considered nonredundant. Failure-critical members in tension may be designated as fracture-critical. Those elements and members whose failure is not expected to cause collapse of the bridge are nonfailure-critical and the associated structural system is considered redundant.



**Figure 6.4.9** Non-redundant Two-Girder Bridge

## 6.4.2

### **Failure Mechanics**

Failure mechanics involves describing the process by which a member fails when subjected to fatigue.

The fatigue failure process of a member consists of three stages:

- Crack initiation
- Crack propagation
- Fracture

#### **Crack Initiation**

Cracks most commonly initiate from points of stress concentrations in structural or connection details. Stress concentrations can result from weld flaws, fatigue prone design and fabrication details, or out-of-plane distortions. The most critical conditions for crack initiation at structural details are those combining a flaw with a detail in a high stress concentration area.

#### **Crack Propagation**

Once a fatigue crack has initiated, applied cyclic stresses cause propagation, or growth, of a crack across the section of the member until it reaches a critical size.

#### **Fracture**

Once a crack has initiated and propagated to a critical size, the member fractures. Fracture of a member is the separation of the member into two parts. The breaking of a fracture critical member may cause a total or partial bridge collapse.

Bridge structures, particularly those that are welded, cannot be fabricated without some flaws and details with high stress concentrations.

Good detailing can reduce the number and severity of stress concentrations, but connecting the girders, stringers, floorbeams, diaphragms, and other members makes it impossible to avoid stress concentrations

## Fatigue Life

The fatigue life of a member is the number of load cycles required to initiate and propagate a fatigue crack to critical size. The number of cycles used to determine fatigue life is based on truck traffic. Cars and buses do not create stresses large enough to contribute to fatigue life. Each load cycle or truck passage causes one or more major stress cycles. Wind and temperature changes may also cause stress cycles, but are not normally considered for fatigue life calculations for primary bridge members.

The number of cycles required to initiate a fatigue crack is the fatigue-crack-initiation life. The number of cycles required to propagate a fatigue crack to a critical size is called the fatigue-crack-propagation life. The total fatigue life is the sum of the initiation and propagation lives.

Bridge engineers use estimations of total fatigue life in predicting the fatigue crack potential of new and existing steel bridge members.

## Types of Fractures

It is common to classify fractures into two failure modes: brittle fracture and ductile fracture.

- Brittle Fracture - Occurs with no warning and without prior plastic deformation (see Figure 6.4.10). Once a brittle fracture occurs, the surface of the fracture is flat.
- Ductile Fracture - Generally preceded by local plastic deformation of the net uncracked section. This plastic deformation results in distortion of the member, providing some visual warning of the impending failure which is the distorted shape which appears when the specimen stretches and necks down in diameter. Once a ductile fracture occurs, the surface of the fracture has shear lips at a 45 degree angle (see Figure 6.4.11).



**Figure 6.4.10** Brittle Fracture of Cast Iron Specimen





**Figure 6.4.11** Ductile Fracture of Cold Rolled Steel Specimen

### Factors that Determine Fracture Behavior

The transition between a brittle and ductile type of fracture is greatly affected by:

**Service temperature** – Different steel types have different transition temperatures. Bridge members exposed to temperatures below their transition temperature, may experience a brittle fracture if they fail. For steels used in fracture critical members the transition temperature is defined as the minimum service temperature for which the Charpy V-notch test value is at least 25 ft–lbs.

**Loading rate** – Rapid loading of a steel member, as may occur from a truck collision or an explosion, can create sufficient energy to cause a member to fail in brittle fracture. Truck loading normally stresses the member at an intermediate loading rate which does not create a high energy level. Variations in the speed at which the truck crosses the bridge do not significantly alter the rate of loading.

**Degree of constraint** – Thick welded plates or complex joints can produce a high degree of constraint that limits the steel's ability to deform plastically. Thinner plates are less prone to fracture, given the same conditions, than are thicker plates.

The risk of a brittle fracture in problematic details is greatly increased when the fracture behavior factors include:

- Cold service temperature
- Rapid truck loading rates
- High degree of constraint (stiff)

Conversely, some plastic deformation leads to a ductile fracture when the fracture behavior factors are:

- Warm service temperature
- Slow truck loading rates

➤ Low degree of constraint (flexible)

The adverse combination of these three factors greatly enhances the likelihood of a brittle fracture. The transition from ductile behavior to brittle is a matter of degree. In either case, when it occurs, the failure of a fracture critical member is sudden and catastrophic.

### Fracture Toughness

The fracture toughness is a quantitative method of expressing of a material's resistance to brittle fracture when a crack is present. Fracture toughness can be defined as the ability of a material to resist crack propagation while under load. Fracture toughness is dependent upon the chemical composition of the material. Steel has greater fracture toughness than iron. Fracture toughness generally depends on the steel type, temperature, together with geometric effects such as constraint. In general, thick welded members made of steel with low toughness are more likely to fracture in low temperatures.

An impact test that is used to determine the fracture toughness of a steel specimen or coupon is called the Charpy V-notch test (see Figure 6.4.12). This test measures the amount of energy absorbed by a test specimen prior to failure. The Charpy V-notch test requirements vary depending on the type of steel, type of construction, whether welded or mechanically fastened, and the applicable minimum service temperature.



Figure 6.4.12 Charpy V-notch Testing Machine

### 6.4.3

#### Factors Affecting Fatigue Crack Initiation

Most critical conditions for fatigue crack initiation are those which involve a combination of flaws and stress concentrations. Girders, stringers, floorbeams, diaphragms, bracing, truss members, hangers, and other members are structurally connected. Bridge structures, particularly those that are welded, cannot be fabricated without details that cause some level of stress concentrations. Good detailing can reduce the number and severity of these stress concentrations in connections.

## Welds

Welds are the connections of metal parts formed by heating the surfaces to a plastic (or fluid) state and allowing the parts to flow together and join with or without the addition of filler material. The term base metal refers to the metal parts that are to be joined. Filler material, or weld material, is the additional metal generally used in the formation of welds. The complete assembly is referred to as a weldment. Conditions of stress concentration are often found in weldments and can be prone to crack initiation.

The four common types of welds found on bridges are groove welds, fillet welds, plug welds, and tack welds.

**Groove Welds** – Groove welds, which are sometimes referred to as butt welds, are used when the members to be connected are lined up edge to edge or are in the same plane (see Figure 6.4.13). Full penetration groove welds extend through the entire thickness of the piece being joined, while partial penetration groove welds do not. Weld reinforcement is the added filler material that causes the throat dimension to be greater than the thickness of the base metal. This weld reinforcement is sometimes ground flush with the base metal to qualify the joint for a better fatigue strength category (see Topic 6.4.5 for descriptions of AASHTO Fatigue Categories).

**Fillet welds** – Fillet welds connect members that either overlap each other or are joined edge to face of plate, as in plate girder assembly of web and flange plates (see Figure 6.4.14). Fillet welds are the most common type of weld because large tolerances in fabrication are allowable when members are lapped over each other instead of fitted together as in groove welds.

**Plug welds** - Plug welds pass through holes in one member to another, with weld metal filling the holes and joining the members together (see Figure 6.4.15). Plug welds have sometimes been used to fill misplaced holes. These repairs are very likely to contain flaws and microcracks that can result in the initiation of fatigue cracking. Plug welds are no longer permitted by AASHTO for bridge construction because they are fatigue prone due to the high degree of constraint and the prominence of weld flaws and slag inclusions. However, AASHTO does permit limited use of plug welds in bridge construction, such as web reinforcement plates (doubler plates) on girder webs at pin and hangers locations.

**Tack welds** - Tack welds are small welds commonly used to temporarily hold pieces in position during fabrication or construction (see Figure 6.4.16). They are often made carelessly, without proper procedures or preheating, and can be a problematic detail when located on a tension member.

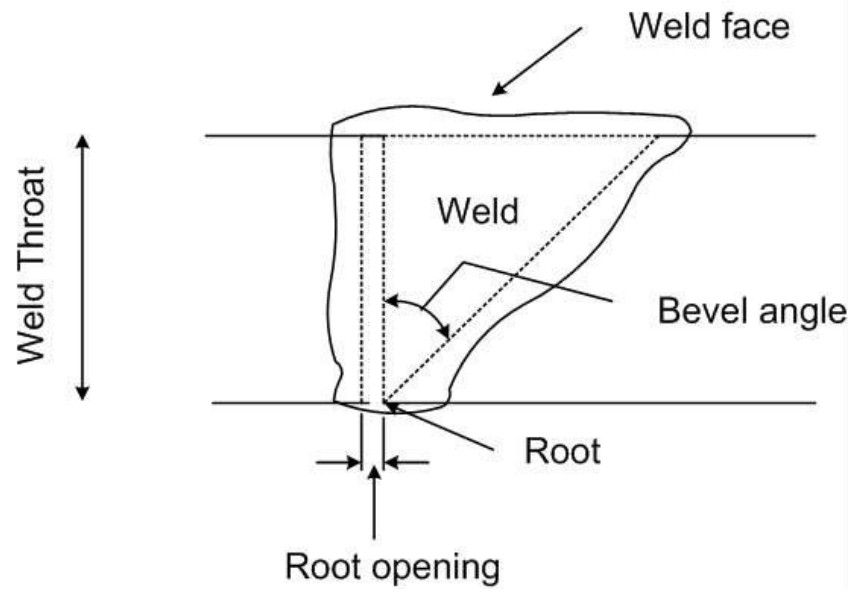


Figure 6.4.13 Groove Weld Nomenclature

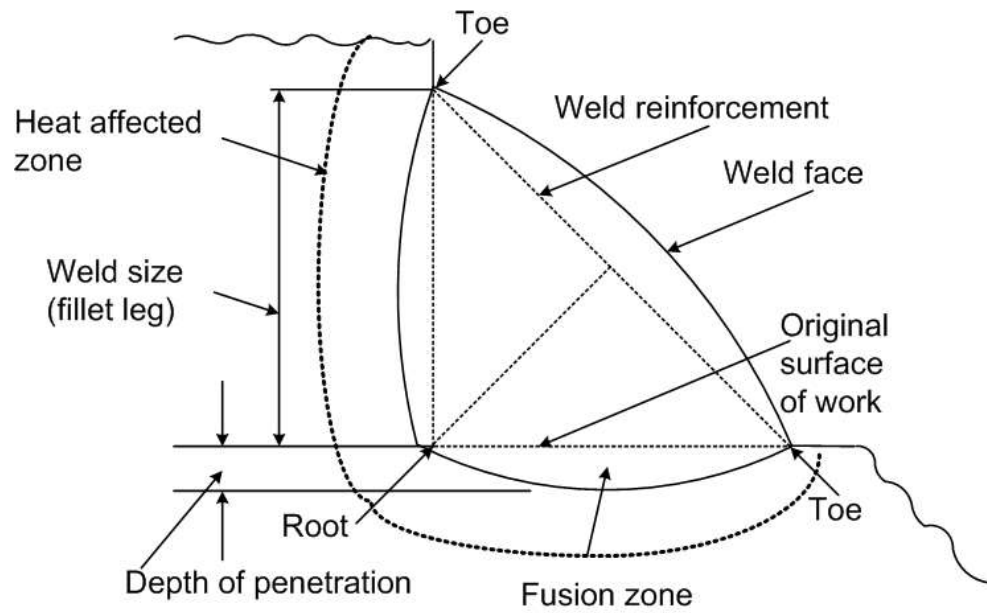
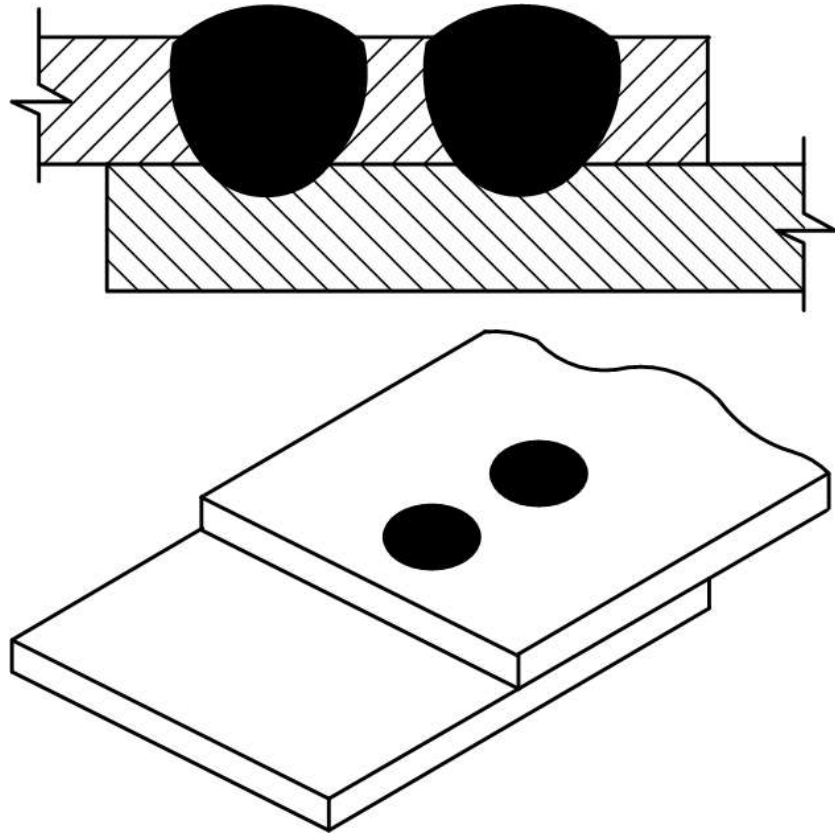
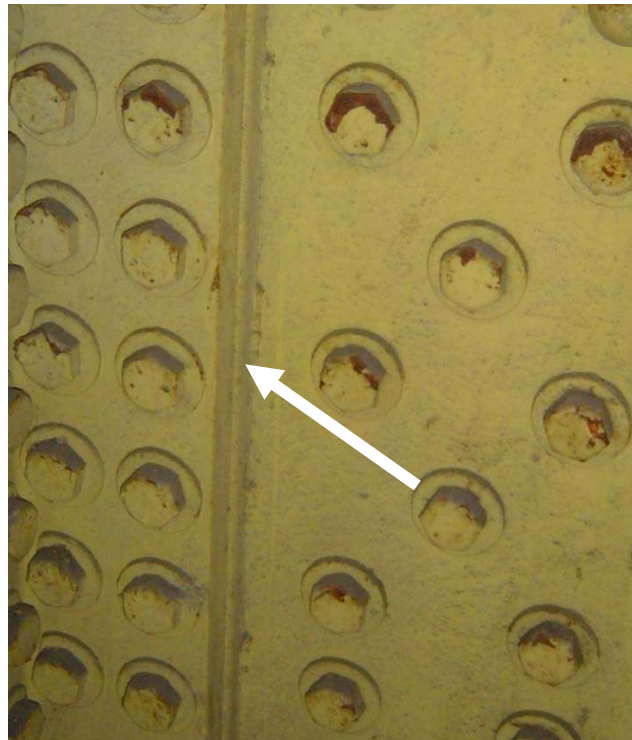


Figure 6.4.14 Fillet Weld Nomenclature



**Figure 6.4.15** Plug Weld Schematic

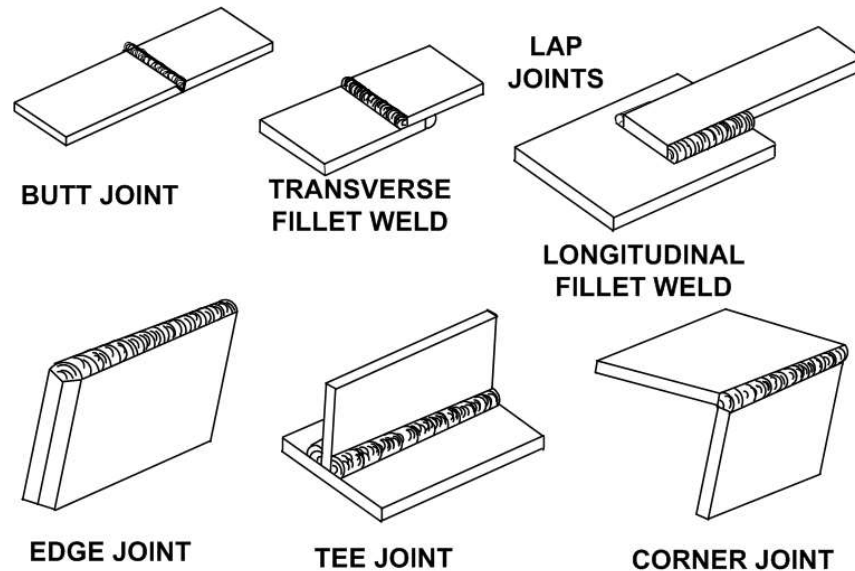


**Figure 6.4.16** Tack Weld

Both plug and tack welds are smaller than fillet and groove welds but they can be the source of serious problems to bridges. They tend to be more problematic than groove and fillet welds. Cracks normally initiate at the weld toes or at any imperfections that may exist in the weld. Cracks from the tack welds often propagate into the base metal.

The joint geometry is also used to describe the weld. Some common weld joints include (see Figure 6.4.17):

- Butt
- Lap
- Tee
- Edge
- Corner



**Figure 6.4.17** Types of Welded Joints

All welding processes result in high built-in residual tension stresses, which are at or near the yield point in the weldment and in the base metal adjacent to it. Load-induced stress concentrations also often occur at welded bridge connections, where these residual tensile stresses are high. This combination of stress concentration and high residual tensile stress is conducive to fatigue crack initiation. Such cracks typically begin either at the weld periphery, such as at the toe of a fillet weld, where there typically can be sharp discontinuities, or else at an internal discontinuity such as a slag inclusion or porosity (explained later). In the initial stages of fatigue crack growth, much of the fatigue life is expended by the time a crack has propagated out of the high residual tensile stress zone.

Bridge structures, particularly those that are welded, can contain flaws whose size and distribution depend upon the:

- Quality of weld and base material
- Fabrication methods

- Erection techniques
- In-service conditions

Flaws vary in size from very small undetectable nonmetallic inclusions to large inherent weld cracks.

### Material Deficiencies

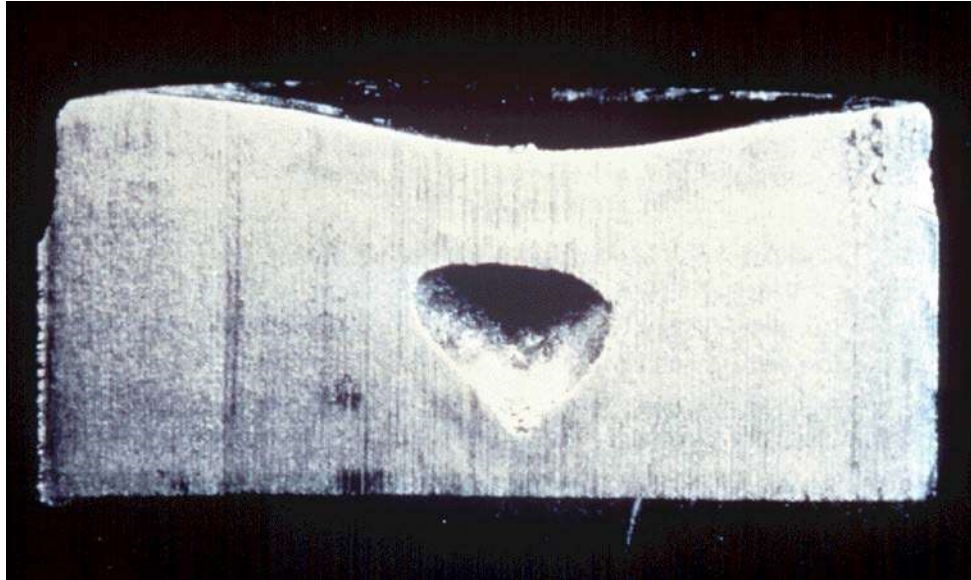
Material deficiencies can occur when there is an incorrect proportion of steel assembled and rolled. This may cause the carbon content or the grain structure to be not conducive in producing today's ductile materials. Material deficiencies may exist in different forms:

- External flaws (e.g., surface laps)
- Internal flaws (e.g., nonmetallic inclusions, laminations and "rolled-in" plate deficiencies (see Figures 6.4.18 & 6.4.19)).



**Figure 6.4.18** Exposed Lamination in Steel Slab

The centerline crack in Figure 6.4.18 may have resulted from a shrinkage cavity like that shown in Figure 6.4.19 which was not forged and melded completely in the hot rolling process.



**Figure 6.4.19** Shrinkage Cavity in Steel Billet

### **Fabrication Flaws**

Fabrication flaws occur when members are joined together to produce elements designed to carry the primary stress. Welding deficiencies are potential discontinuities in welded members that could lead to a fatigue crack.

Fabrication can introduce a variety of visible and non-visible flaws. Typical non-visible weld deficiencies include:

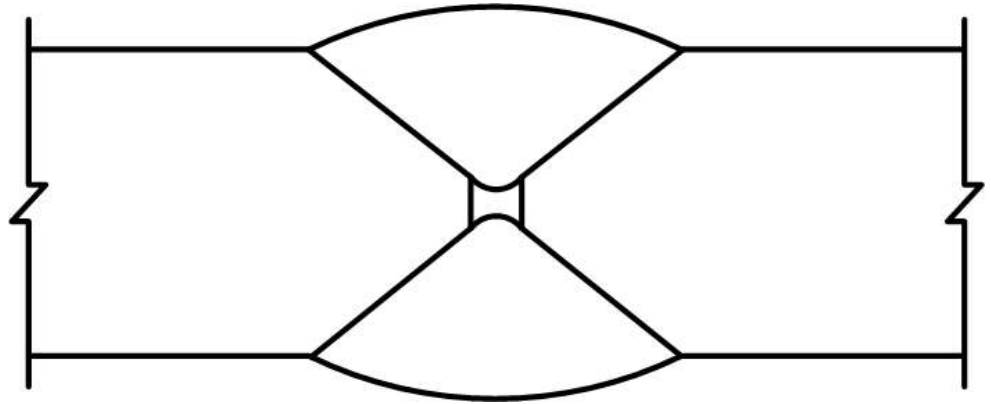
**Incomplete Penetration** – Incomplete penetration occurs when the weld metal fails to penetrate the root of a joint or fails to fuse completely with the root face of the base metal (see Figure 6.4.20). Incomplete penetration is not permitted for most bridge applications. Incomplete penetration welds cause a local stress riser at the root of a weld and can reduce the load-carrying capacity of the member. A stress riser is a detail that causes stress concentration.

**Lack of fusion** – Lack of fusion is a condition in which boundaries of unfused metal exist either between the base metal and weld metal or between adjacent layers of weld metal (see Figure 6.4.21). Lack of fusion is generally a result of poor welding techniques, can seriously reduce the load-carrying capacity of the member, and could be a point of crack initiation at a lower stress.

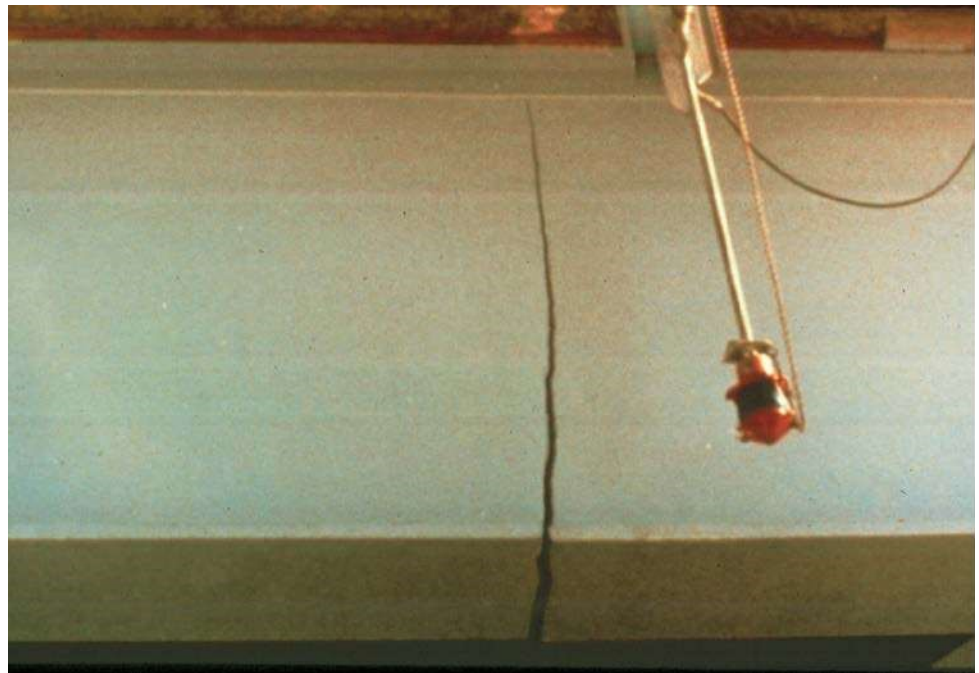
**Slag inclusions** – Slag inclusion occurs when nonmetallic matter is inadvertently trapped between the weld metal and the base metal (see Figure 6.4.22). Slag from the welding rod shield may be forced into the weld metal by the arc during the welding operation. If large, irregular inclusions or lengthy lines of inclusions are present, crack initiation at a lower stress could begin and the strength of the weld may be considerably reduced. However, small isolated globe shaped inclusions do not seriously affect the strength of a weld, but can be a point of crack initiation.

**Porosity** – Porosity is the presence of cavities in the weld metal caused by entrapped gas and takes the form of small spherical cavities, either scattered throughout the weld or clustered in local regions (see Figure 6.4.23). It is tolerated if the amount does not exceed specified quantities relative to weld size. Sometimes, porosity is visible on the surface of the weld.

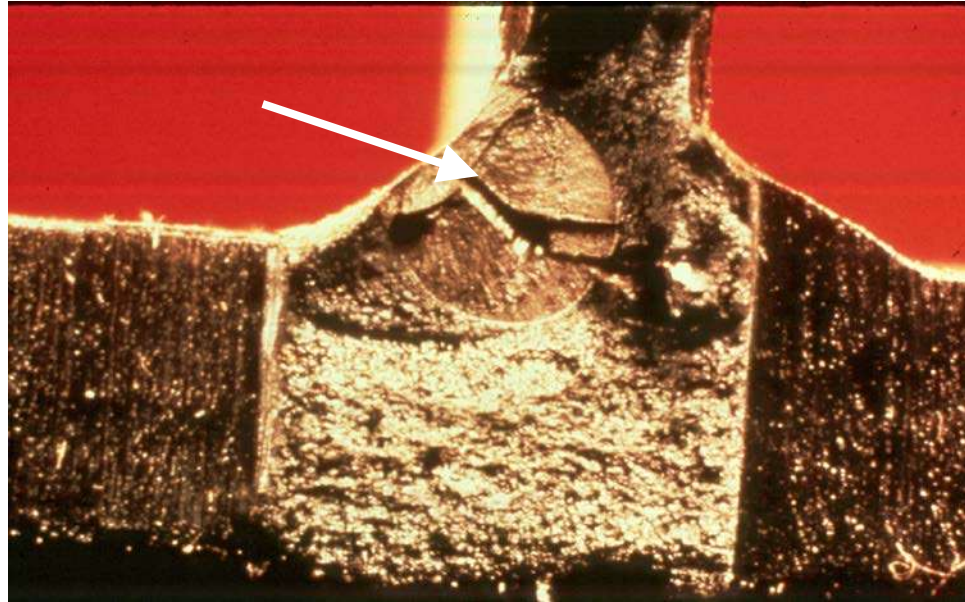




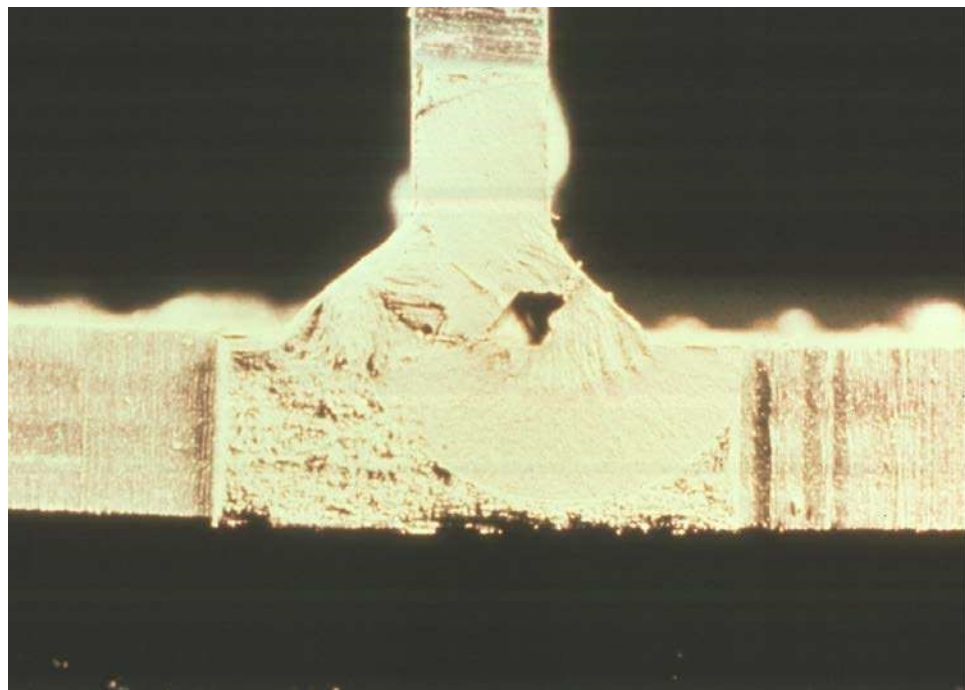
**Figure 6.4.20** Incomplete Penetration of a Double V-Groove Weld



**Figure 6.4.21** Crack Initiation from Lack of Fusion in Heat Affected Zone of Electroslag Groove Weld of a Butt Joint



**Figure 6.4.22** Web to Flange Crack due to Fillet Weld Slag Inclusion



**Figure 6.4.23** Crack Initiation from Porosity in Longitudinal Web-to-Flange Fillet Weld of Plate Girder

Plug welds are sometimes found in bridge members. In most cases, they were made to fill mislocated bolt holes. Such welds are highly restrained and often contain incomplete penetration, lack of fusion, slag inclusions, and porosity. There have been many instances where a crack and fracture have occurred because of a plug weld (see Figure 6.4.24).



**Figure 6.4.24** Crack Resulting from Plug Welded Holes

Visible weld deficiencies include:

Improper welding practices

- Improper type and size of electrode - Electrodes are to suit the metal being joined, the welding position, the function of the weld, the plate thickness, and the size of the joint.
- Improper welding current and polarity - Welding current and polarity are to suit the type of electrode used and the joint to be made.
- Improper preheat and interpass temperature - Preheating and the required temperature level depends on the plate thickness, the grade of steel, the welding process, and ambient temperatures. Where these conditions dictate the need, make periodic checks to ensure adherence to requirements.

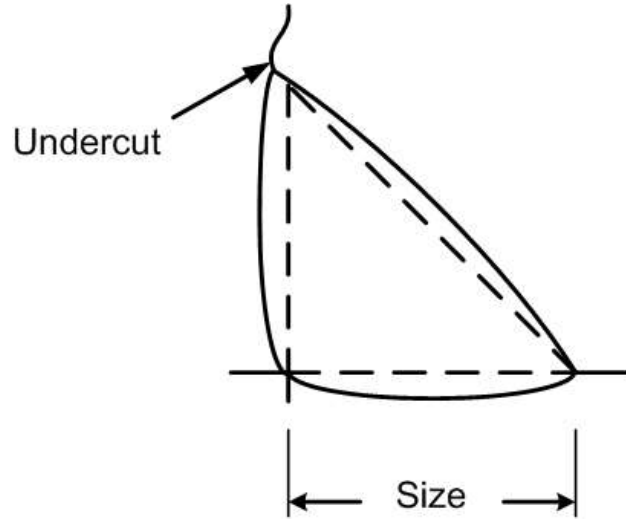
**Undercut** – The condition in which a local reduction in a section of base metal occurs alongside the weld deposit. This may happen either on the surface of the base metal at the toe of the weld, or in the fusion face of multiple pass welds due to overheating. This groove creates a mechanical notch, which is a stress riser (see Figure 6.4.25). When an undercut is controlled within the limits of specifications and does not constitute a sharp or deep notch, it is not seen as a serious deficiency.

**Overlap** – Overlap is a weld flaw at the toe of a weld in which the weld metal overflows onto the surface of the base metal without fusing to it due to insufficient heat (see Figure 6.4.26). This condition may exist intermittently or continuously along the weld joint. Discontinuity at the toe of a weld acts as a stress riser and reduces the fatigue strength of the member.

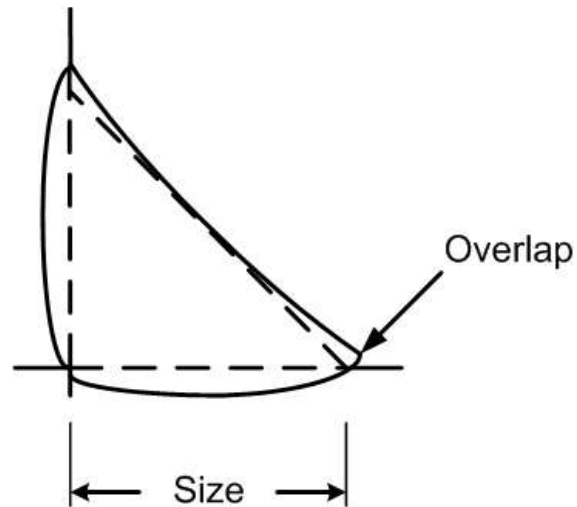
**Cleanliness of the joint** - Joint and plate surfaces are to be cleaned of dirt, rust, and

moisture. This is especially important on those surfaces to be fused with the deposited weld metal. Mill scale during fabrication may interfere with surfaces fused together properly.

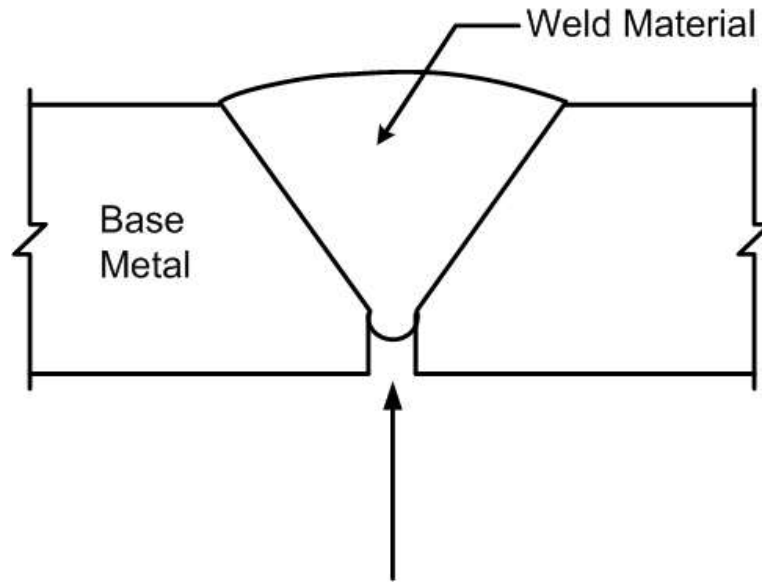
Incomplete penetration – When incomplete penetration occurs due to the failure of the weld material to fuse completely with the root face of the base material, a deficiency results.



**Figure 6.4.25** Undercut of a Fillet Weld



**Figure 6.4.26** Overlap of a Fillet Weld



**Figure 6.4.27** Incomplete Penetration of a V-Groove Weld

Other fabrication flaws include:

**Craters** – Craters are a depression at the termination of an arc weld. They may be a problem if they are undersized (i.e., not full throat) and/or they are concave, since they might crack upon cooling. Normally, on continuous fillet welds, there is no crater problem because each crater is filled by the next weld. The welder starts the arc at the outer end of the last crater and momentarily swings back into the crater to fill it before going ahead for the next weld.

**Cracks** – There are to be no cracks of any kind, either in the weld or in the heat-affected zone of the welded member.

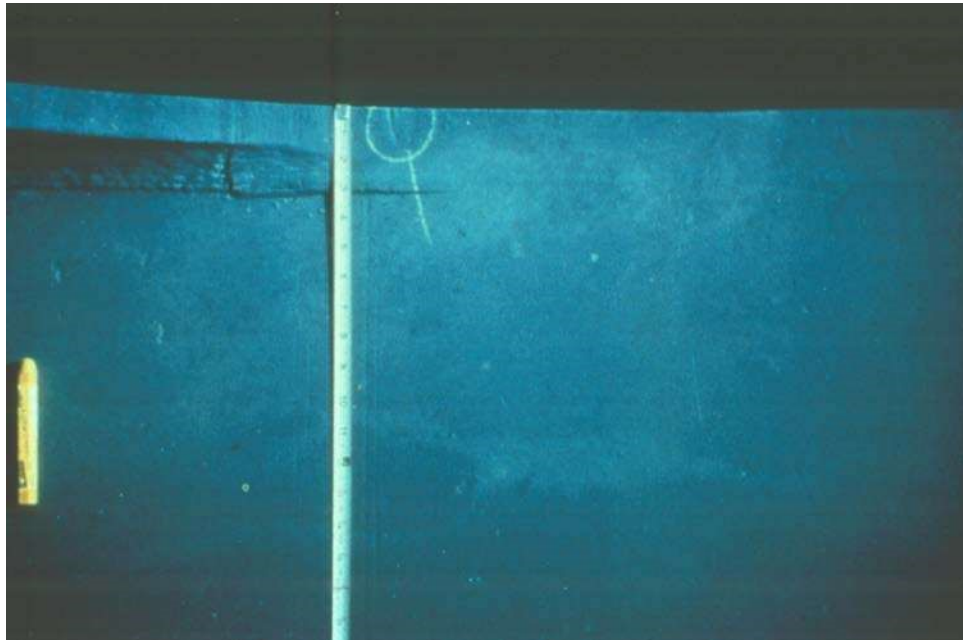
**Bolt and rivet holes** – Holes of any kind in the base metal create a stress riser. Punched holes for rivets, without reaming, contain gouges that can initiate a crack. The stresses can increase when going around a hole. Burrs generated during the drilling process are additional risers and have to be removed.

**Beam coping** – When flange/web copings do not have the proper radius as per AASHTO specifications a stress riser is created (see Figure 6.4.28).

**Flame cuts** – Flame cutting, although fast, creates large surface discontinuities that are stress risers (see Figure 6.4.29). The surfaces of flame cut plates in tension are to be ground smooth in the direction of the tensile stress.

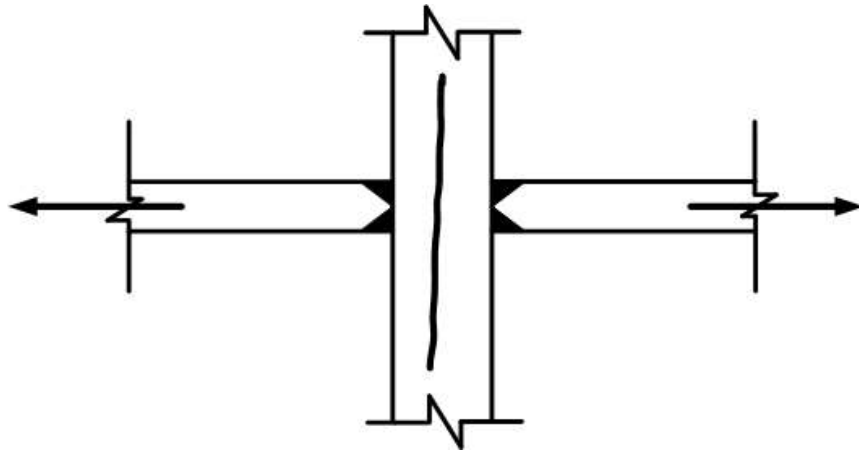


**Figure 6.4.28** Crack Initiation at Coped Web in Stringer to Floorbeam



**Figure 6.4.29** Insufficiently Ground Flame Cut of Gusset Plate for Arch to Tie Girder Connection

Lamellar tear - Applied tensile stress across the thickness of a plate due to weld quenching (cooling down) can induce internal lamellar tearing of the plate which is produced during fabrication (see Figure 6.4.30).



**Figure 6.4.30** Thick plate with Two Plates Welded to it and Showing a Lamellar Tear

### Transportation and Erection Flaws

Careless handling during transportation and erection may leave the following flaws along the edges of members:

**Out-of-Plane Bending Forces** – Sometimes during transport, beams are supported in a manner not accounted for in the original design. Horizontal and vertical deflections can cause out-of-plane bending about an unintended axis. Beams are to be securely blocked to resist cyclic side-sway movement during truck, barge or rail transport. There have been extreme cases where cracks have initiated in beams before they have been erected.

**Nicks, Notches, and Indentations** – Beam handling devices such as lifting tongs develop intense pressure at the point of contact and can cause measurable indentations and gouges. When transporting steel beams, chains are commonly used to secure the beam to the truck or railroad car which can create notches on the corners of steel members. These notches can lead to stress concentrations.

**Tack Welds** – Tack welding was a common practice in the mid 1950's and through the early 1960's and was applied to hold members together during erection. When left in place and exposed to tensile stress, they are a potential crack initiation location. Tack welds are to be avoided if possible. But if they are used, they are to be small and long so they won't interfere with subsequent submerged-arc welds and incorporated into the final weld.

### In-Service Flaws

Once the structure is placed in service, environmental conditions, traffic and retrofits can contribute to fatigue crack initiation. The most common in-service flaws include:

**Impact damage** - Some members may be prone to collision damage by errant vehicles which may nick, tear, and excessively stress the steel (see Figure 6.4.31).

**Indiscriminate welds** - Indiscriminate application of welded attachments such as

conduit supports, lighting attachments, and ladder brackets to steel members can cause stress risers in the base metal. Field conditions do not support high quality welds which can typically lead to weld flaws and lead to cracking.

Corrosion - Deep corrosion pits can develop in structures that are improperly detailed for corrosion control, poorly maintained, or left unpainted.

Improper heat straightening – When insufficient heat is applied during straightening (as in fixing collision damage), physical manipulation of the steel can induce plastic deformation which can strain harden the affected area.



**Figure 6.4.31** Severe Collision Damage on a Fascia Girder

In summary, bridges can contain significant flaws or problematic details that can be the point of initiation of fatigue cracking and possibly result in fracture. Problematic details are identified prior to a fracture critical inspection.

## 6.4.4

### **Factors Affecting Fatigue Crack Propagation**

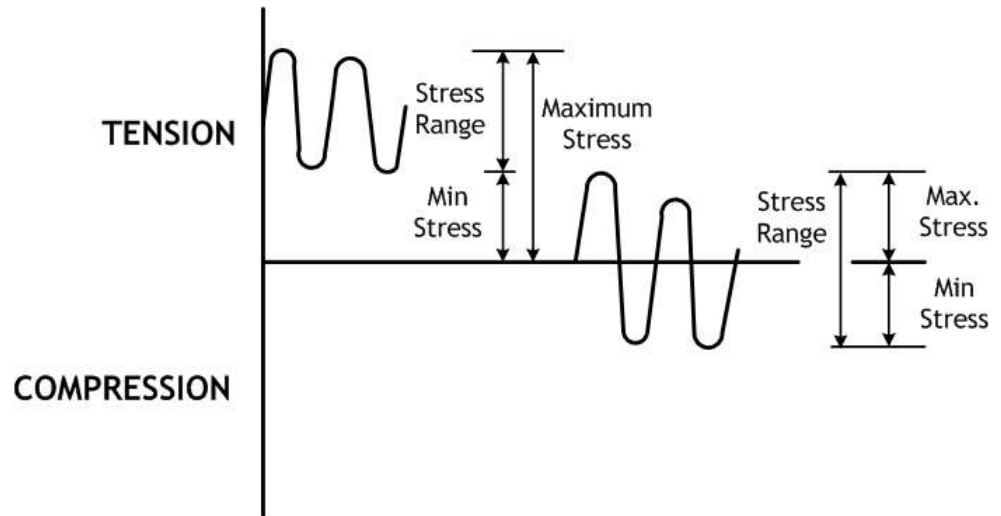
Failures due to cracking develop as a result of cyclic loading and usually provide little evidence of plastic deformation. Hence, they are often difficult to see before serious distress develops in the member. Fatigue cracks generally require large magnitudes of cyclic stresses, corresponding to a high frequency of occurrence or to a long exposure time. Structural details have various amounts of resistance to fatigue cracks caused by these large magnitudes of cyclic stresses. The three major parameters affecting fatigue crack propagation life are:

- Stress range
- Number of cycles
- Type of details



**Stress Range**

The stress range is defined as the algebraic difference between the maximum stress and the minimum stress calculated at the detail under consideration. In other words, it is the value of the cyclic stress caused by a truck crossing the bridge (see Figure 6.4.32). The weight or dead load of the bridge produces a constant stress instead of a cyclic stress. Therefore, it does not affect the crack propagation life. Only stress ranges in tension or stress reversal can drive fatigue cracks to failure. Stress ranges in compression may cause cracks to grow to some extent at weldments where there are high residual tensile stresses. However, these "compression" cracks eventually arrest, and they do not induce fracture of the member. Only stress ranges in tension or stress reversal can drive fatigue cracks.



**Figure 6.4.32** Applied Tensile and Compressive Stress Cycles

**Number of Cycles**

The number of stress cycles (frequency) is proportional to the number of trucks that cross the bridge during its service life. Each truck passage causes one or more major stress cycles. The number of cycles a bridge is subjected to is related to the age, location and span configuration of the structure. The number of cycles may eventually lead to fatigue cracks.

**Types of Details**

“Type of details” refers to the connection configuration in a particular area of the bridge. There are many problematic details used in the connections of bridges. AASHTO has chosen some typical details, or Illustrative Examples (see Figure 6.4.43). These Illustrative Examples are used to help determine AASHTO Fatigue Categories (see Topic 6.4.5).

Various details have different fatigue strengths associated with them. This is usually determined by the quality of the fabricated detail or the weld quality. It is common practice among bridge engineers to group steel bridge structural details into several AASHTO categories (A through E') of fatigue resistance. By doing this, the bridge engineer can design against risk levels of fatigue failure of the various details (i.e., details of higher fatigue strength categories are allowed higher stress ranges than the lower category details). In other words, details of higher fatigue strength categories (A & B), are allowed higher stress ranges than those in the lower category details (D through E').

Other factors influencing the development of fatigue cracks are:

Material Fracture Toughness

Toughness of the:

- Base metal
- Weld metal

Toughness is based on the chemical composition of the steel.

Ambient Temperature

- Colder – more likely to crack

**Flange Crack Failure Process**

A common location for initiation of a flange crack is at the end of a partial length cover plate welded longitudinally along its sides and transversely across the ends as it is attached to the tension flange of a rolled beam.

One or more cracks can initiate from microscopic flaws or deficiencies at the weld toe of the transverse end weld (see Figure 6.4.33). Such cracking may then advance in three stages:



**Figure 6.4.33** Part-Through Crack at a Cover Plated Flange

Stage 1

In the first stage, a part-through surface crack is only barely visible as a hairline on the bottom of the flange at the toe of weld. As stress is applied, the small cracks that have initiated join each other and begin to form a larger part-through surface crack (see Figure 6.4.34).



**Figure 6.4.34** Part-Through Crack Growth at Cover Plate Welded to Flange

The crack front develops a thumbnail or half penny shape as it propagates in the thickness direction of the flange until reaching the inside surface. Once it breaks through the thickness of the flange, the shape rapidly changes into that of a three-ended crack.

Crack propagation begins at a very slow rate and gradually accelerates as the crack grows in size. Approximately 95% of the fatigue life is spent growing the Stage 1 part-through crack.

#### Stage 2

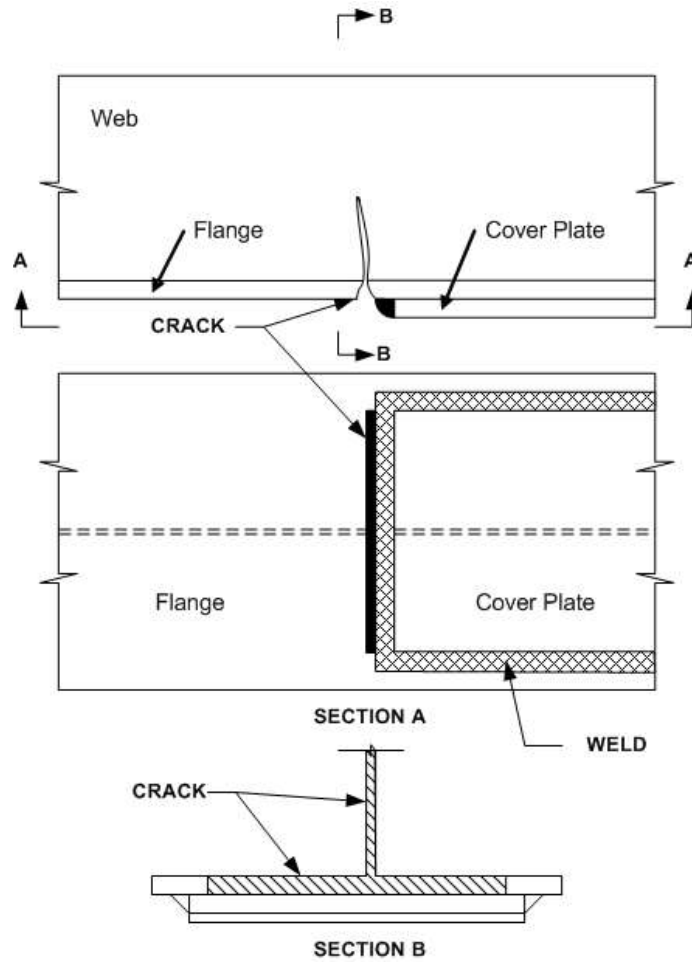
During the second stage, the crack then propagates with two fronts moving across the flange width and one front moving into the web until it reaches a critical size, at which time the member may fracture (see Figure 6.4.35).

The crack is readily visible as a through-the-thickness crack on both the top and bottom surfaces of the flange (see Figure 6.4.36).

Approximately 5% of the fatigue life is left for growing the Stage 2 through crack (see Figure 6.4.37).

#### Stage 3

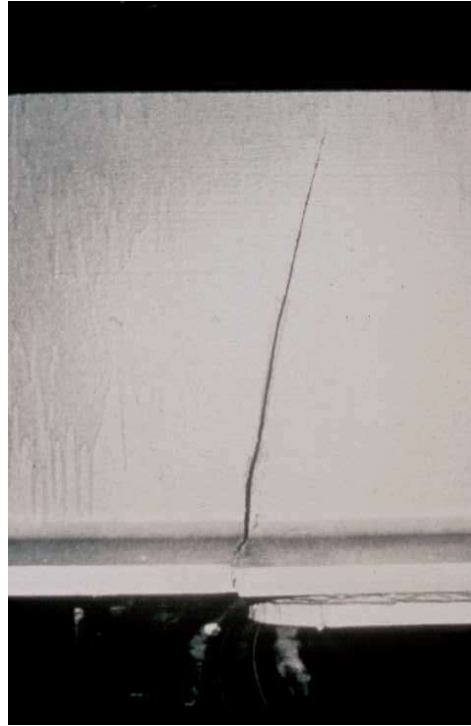
When a crack propagates to a critical size, the member fractures. Fracture is the separation of the member into two parts. When the member is fracture critical, the span, or a portion of it, likely collapses.



**Figure 6.4.35** Through Crack Growth at Cover Plate Welded to Flange



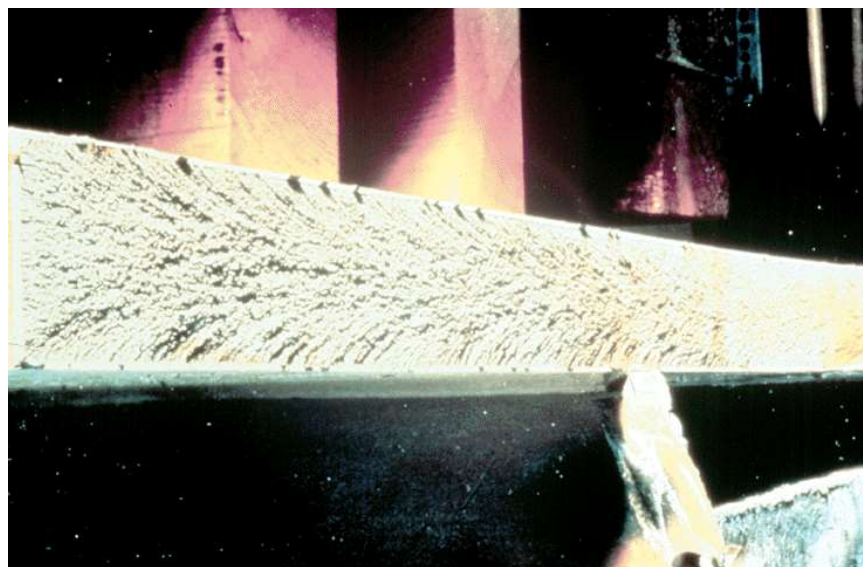
**Figure 6.4.36** Through Crack at a Cover Plated Flange



**Figure 6.4.37** Through Crack has Propagated into the Web  
Inspection

It is important the inspector realizes that cracks are only readily detectable visually as a through crack after most of the fatigue life of the detail is gone. Therefore, notify the bridge owner immediately whenever cracks are found in a flange.

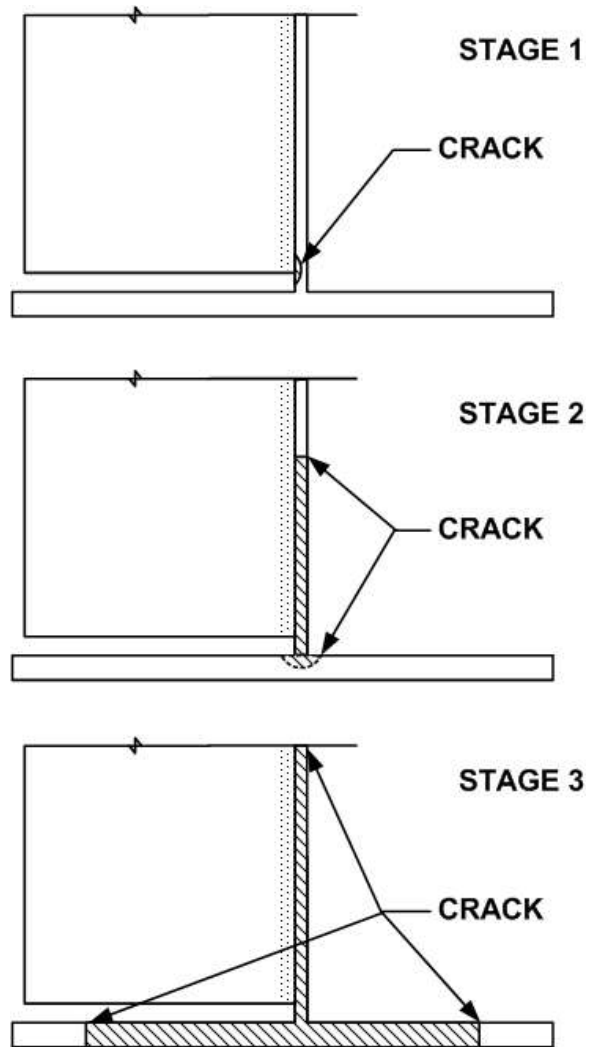
When the fatigue life is finally used up, that is the fatigue crack has grown to a critical size and stress intensity, the fracture then occurs. The brittle fracture surface appears crystalline or uneven, and often reveals a herringbone pattern oriented toward the point of fracture initiation (see Figure 6.4.38).



**Figure 6.4.38** Brittle Fracture – Herringbone Pattern

**Web Crack Failure Process**

A common location for initiation of a web crack is at the weld toe of a transverse stiffener that is welded to the web of a beam. This type of crack grows in three stages (see Figure 6.4.39):

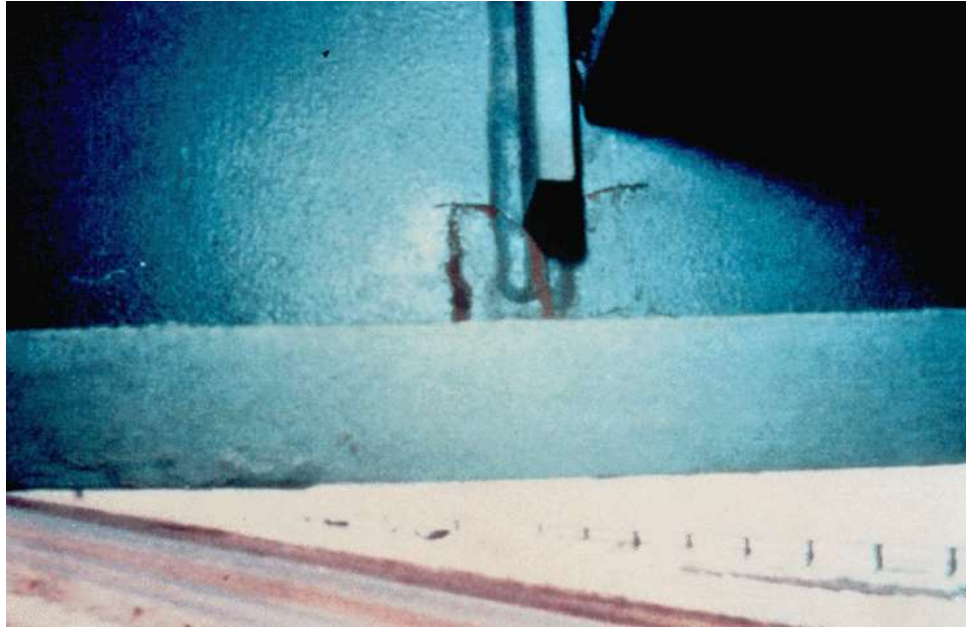


**Figure 6.4.39** Crack Growth at Transverse Stiffener Welded to Web

**Stage 1**

A fatigue crack initiates at the weld toe near the end of the stiffener and propagates during the first stage as a part-through crack in the thickness direction of the web until it reaches the opposite face of the web.

A part-through stiffener crack is often just barely visible as a hairline along the toe of the weld (see Figure 6.4.40).



**Figure 6.4.40** Part-Through Web Crack

This type of stiffener crack expends about 95% of its fatigue life propagating in Stage 1.

Stage 2

After it breaks through the web, the shape changes into a two-ended (or more) through crack which propagates up and down the web (see Figure 6.4.41). The through crack can be readily seen on both sides of the web. The stiffener crack expends about 5% of the fatigue life propagating in Stage 2.



**Figure 6.4.41** Through Crack in the Web

Stage 3

Eventually, the lower crack front reaches the bottom flange, and the three-ended crack then propagates with two fronts moving across the flange and one front moving farther up the web, until the member fractures (see Figure 6.4.42).



**Figure 6.4.42** Through-Crack Ready to Propagate into the Flange

The through crack can usually readily be seen on both sides of the web and on both sides of the flange.

Bring any web cracks discovered to the immediate attention of a bridge owner.

## 6.4.5

### **AASHTO Detail Categories for Load-Induced Fatigue**

For purposes of designing bridges for fatigue caused by in-plane bending stress, the details are grouped into categories labeled A to E'. These categories are presented in the AASHTO *LRFD Bridge Design Specifications* Table 6.6.1.2.3-1 - Details for Load-Induced Fatigue (see Figure 6.4.43). For existing bridges these categories provide a method for the inspector to classify fatigue prone details. AASHTO Fatigue Categories are based on the load induced fatigue. Load-Induced fatigue is due to “in-plane” bending. In-plane bending occurs parallel to the longitudinal axis. The classification of details by category does not apply to details that crack due to out-of-plane distortion.

Each letter represents a rating given to a detail which indicates its level of fatigue strength, level “A” offering the highest and level “E' ” having the lowest resistance. Note that the 1998 AASHTO *Bridge Design Specifications* (2<sup>nd</sup> edition) have eliminated Category F. Category E can be conservatively applied in place of Category F. The details assigned to the same category have about equally severe stress concentrations and comparable fatigue lives. The alphabetical classification by the severity of the stress concentration is a useful method of identifying fatigue strength.

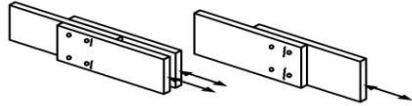
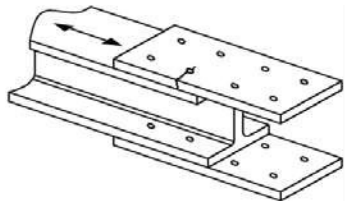
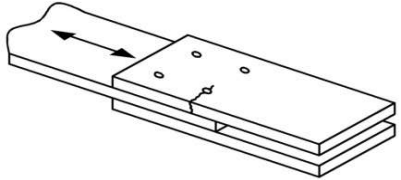
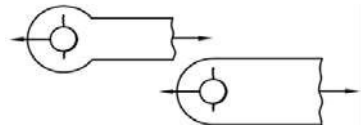


When used in fracture critical inspections, these fatigue categories serve as a reminder of which details are prone to fatigue cracking. They also prioritize the level of effort expanded to inspect each detail. The categories are defined as follows.

Description	Category	Constant $A$ (ksi <sup>3</sup> )	Threshold $(\Delta F)_{TH}$ ksi	Potential Crack Initiation Point	Illustrative Examples
Section 1—Plain Material away from Any Welding					
1.1 Base metal, except noncoated weathering steel, with rolled or cleaned surfaces. Flame-cut edges with surface roughness value of 1,000 μ-in. or less, but without re-entrant corners.	A	$250 \times 10^8$	24	Away from all welds or structural connections	
1.2 Noncoated weathering steel base metal with rolled or cleaned surfaces designed and detailed in accordance with FHWA (1989). Flame-cut edges with surface roughness value of 1,000 μ-in. or less, but without re-entrant corners.	B	$120 \times 10^8$	16	Away from all welds or structural connections	
1.3 Member with re-entrant corners at copes, cuts, block-outs or other geometrical discontinuities made to the requirements of AASHTO/AWS D1.5, except weld access holes.	C	$44 \times 10^8$	10	At any external edge	
1.4 Rolled cross sections with weld access holes made to the requirements of AASHTO/AWS D1.5, Article 3.2.4.	C	$44 \times 10^8$	10	In the base metal at the re-entrant corner of the weld access hole	
1.5 Open holes in members (Brown et al. 2007).	D	$22 \times 10^8$	7	In the net section originating at the side of the hole	

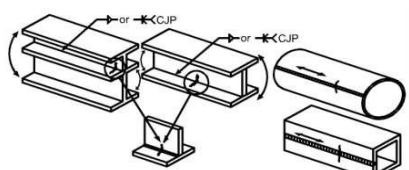
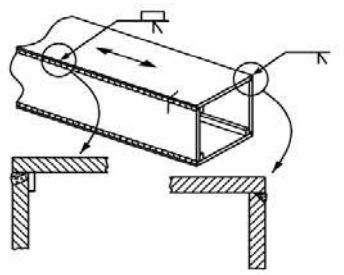
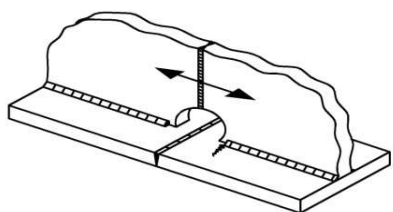
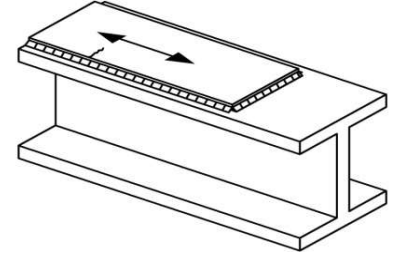
**Figure 6.4.43** AASHTO LRFD Bridge Design Specifications, 5<sup>th</sup> Edition, with 2010 Interim Revisions, Table 6.6.1.2.3-1 - Detail Categories for Load-Induced Fatigue

Source: American Association of State Highway and Transportation Officials

Description	Category	Constant $A$ (ksi <sup>3</sup> )	Threshold $(\Delta F)_{TH}$ ksi	Potential Crack Initiation Point	Illustrative Examples
Section 2—Connected Material in Mechanically Fastened Joints					
2.1 Base metal at the gross section of high-strength bolted joints designed as slip-critical connections with pre-tensioned high-strength bolts installed in holes drilled full size or subpunched and reamed to size – e.g. bolted flange and web splices and bolted stiffeners. (Note: see Condition 2.3 for bolt holes punched full size.)	B	$120 \times 10^8$	16	Through the gross section near the hole	
2.2 Base metal at the net section of high-strength bolted joints designed as bearing-type connections, but fabricated and installed to all requirements for slip-critical connections with pre-tensioned high strength bolts installed in holes drilled full size or subpunched and reamed to size. (Note: see Condition 2.3 for bolt holes punched full size.)	B	$120 \times 10^8$	16	In the net section originating at the side of the hole	
2.3 Base metal at the net section of all bolted connections in hot dipped galvanized members (Huhn and Valtinat 2004); base metal at the appropriate section defined in Condition 2.1 or 2.2, as applicable, of high strength bolted joints with pretensioned bolts installed in holes punched full size (Brown et al. 2007), and base metal at the net section of other mechanically fastened joints, except for eyebars and pin plates; e.g., joints using A307 bolts or non pretensioned high strength bolts.	D	$22 \times 10^8$	7	In the net section originating at the side of the hole or through the gross section near the hole, as applicable	
2.4 Base metal at the net section of eyebar heads or pin plates (Note: for base metal in the shank of eyebars or through the gross section of pin plates, see Condition 1.1 or 1.2, as applicable).	E	$11 \times 10^8$	4.5	In the net section originating at the side of the hole	

**Figure 6.4.43** AASHTO LRFD Bridge Design Specifications, 5<sup>th</sup> Edition, with 2010 Interim Revisions, Table 6.6.1.2.3-1 - Detail Categories for Load-Induced Fatigue, continued

Source: American Association of State Highway and Transportation Officials

Description	Category	Constant $A$ (ksi <sup>3</sup> )	Threshold $(\Delta F)_{TH}$ ksi	Potential Crack Initiation Point	Illustrative Examples
<b>Section 3—Welded Joints Joining Components of Built-Up Members</b>					
3.1 Base metal and weld metal in members without attachments built-up of plates or shapes connected by continuous longitudinal complete joint penetration groove welds back-gouged and welded from the second side, or by continuous fillet welds parallel to the direction of applied stress.	B	$120 \times 10^8$	16	From surface or internal discontinuities in the weld away from the end of the weld	
3.2 Base metal and weld metal in members without attachments built-up of plates or shapes connected by continuous longitudinal complete joint penetration groove welds with backing bars not removed, or by continuous partial joint penetration groove welds parallel to the direction of applied stress.	B'	$61 \times 10^8$	12	From surface or internal discontinuities in the weld, including weld attaching backing bars	
3.3 Base metal and weld metal at the termination of longitudinal welds at weld access holes made to the requirements of AASHTO/AWS D1.5, Article 3.2.4 in built-up members. (Note: does not include the flange butt splice).	D	$22 \times 10^8$	7	From the weld termination into the web or flange	
3.4 Base metal and weld metal in partial length welded cover plates connected by continuous fillet welds parallel to the direction of applied stress.	B	$120 \times 10^8$	16	From surface or internal discontinuities in the weld away from the end of the weld	

**Figure 6.4.43** AASHTO LRFD Bridge Design Specifications, 5<sup>th</sup> Edition, with 2010 Interim Revisions, Table 6.6.1.2.3-1 - Detail Categories for Load-Induced Fatigue, continued

Source: American Association of State Highway and Transportation Officials

Description	Category	Constant $A$ (ksi <sup>3</sup> )	Threshold $(\Delta F)_{TH}$ ksi	Potential Crack Initiation Point	Illustrative Examples
<p>3.5 Base metal at the termination of partial length welded cover plates having square or tapered ends that are narrower than the flange, with or without welds across the ends, or cover plates that are wider than the flange with welds across the ends:</p> <p>Flange thickness <math>\leq 0.8</math> in.                      Flange thickness <math>&gt; 0.8</math> in.</p>	E E'	$11 \times 10^8$ $3.9 \times 10^8$	4.5 2.6	In the flange at the toe of the end weld or in the flange at the termination of the longitudinal weld or in the edge of the flange with wide cover plates	
<p>3.6 Base metal at the termination of partial length welded cover plates with slip-critical bolted end connections satisfying the requirements of Article 6.10.12.2.3.</p>	B	$120 \times 10^8$	16	In the flange at the termination of the longitudinal weld	
<p>3.7 Base metal at the termination of partial length welded cover plates that are wider than the flange and without welds across the ends.</p>	E'	$3.9 \times 10^8$	2.6	In the edge of the flange at the end of the cover plate weld	
Section 4—Welded Stiffener Connections					
<p>4.1 Base metal at the toe of transverse stiffener-to-flange fillet welds and transverse stiffener-to-web fillet welds. (Note: includes similar welds on bearing stiffeners and connection plates).</p>	C'	$44 \times 10^8$	12	Initiating from the geometrical discontinuity at the toe of the fillet weld extending into the base metal	
<p>4.2 Base metal and weld metal in longitudinal web or longitudinal box-flange stiffeners connected by continuous fillet welds parallel to the direction of applied stress.</p>	B	$120 \times 10^8$	16	From the surface or internal discontinuities in the weld away from the end of the weld	

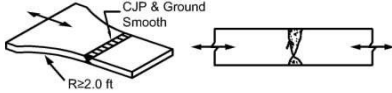
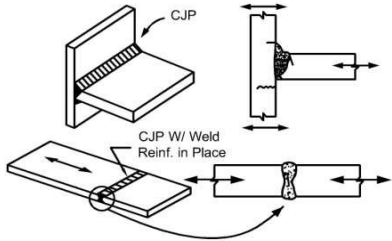
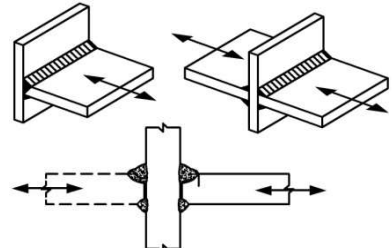
**Figure 6.4.43** AASHTO LRFD Bridge Design Specifications, 5<sup>th</sup> Edition, with 2010 Interim Revisions, Table 6.6.1.2.3-1 - Detail Categories for Load-Induced Fatigue, continued

Source: American Association of State Highway and Transportation Officials

Description	Category	Constant $A$ (ksi <sup>3</sup> )	Threshold $(\Delta F)_{TH}$ ksi	Potential Crack Initiation Point	Illustrative Examples
<p>4.3 Base metal at the termination of longitudinal stiffener-to-web or longitudinal stiffener-to-box flange welds:</p> <p>With the stiffener attached by fillet welds and with no transition radius provided at the termination:</p> <p>Stiffener thickness &lt; 1.0 in.                      Stiffener thickness ≥ 1.0 in.</p> <p>With the stiffener attached by welds and with a transition radius <math>R</math> provided at the termination with the weld termination ground smooth:</p> <p><math>R \geq 24</math> in                      24 in. &gt; <math>R \geq 6</math> in.                      6 in. &gt; <math>R \geq 2</math> in.                      2 in. &gt; <math>R</math></p>	<p>E                      E'</p> <p>B                      C                      D                      E</p>	<p><math>11 \times 10^8</math>  <math>3.9 \times 10^8</math></p> <p><math>120 \times 10^8</math>  <math>44 \times 10^8</math>  <math>22 \times 10^8</math>  <math>11 \times 10^8</math></p>	<p>4.5                      2.6</p> <p>16                      10                      7                      4.5</p>	<p>In the primary member at the end of the weld at the weld toe</p> <p>In the primary member near the point of tangency of the radius</p>	
Section 5—Welded Joints Transverse to the Direction of Primary Stress					
<p>5.1 Base metal and weld metal in or adjacent to complete joint penetration groove welded butt splices, with weld soundness established by NDT and with welds ground smooth and flush parallel to the direction of stress. Transitions in thickness or width shall be made on a slope no greater than 1:2.5 (see also Figure 6.13.6.2-1).</p> <p><math>F_y &lt; 100</math> ksi  <math>F_y \geq 100</math> ksi</p>	<p>B                      B'</p>	<p><math>120 \times 10^8</math>  <math>61 \times 10^8</math></p>	<p>16                      12</p>	<p>From internal discontinuities in the filler metal or along the fusion boundary or at the start of the transition</p>	

**Figure 6.4.43** AASHTO LRFD Bridge Design Specifications, 5<sup>th</sup> Edition, with 2010 Interim Revisions, Table 6.6.1.2.3-1 - Detail Categories for Load-Induced Fatigue, continued

Source: American Association of State Highway and Transportation Officials

Description	Category	Constant $A$ (ksi <sup>.3</sup> )	Threshold $(\Delta F)_{TH}$ ksi	Potential Crack Initiation Point	Illustrative Examples
5.2 Base metal and weld metal in or adjacent to complete joint penetration groove welded butt splices, with weld soundness established by NDT and with welds ground parallel to the direction of stress at transitions in width made on a radius of not less than 2 ft with the point of tangency at the end of the groove weld (see also Figure 6.13.6.2-1).	B	$120 \times 10^8$	16	From internal discontinuities in the filler metal or discontinuities along the fusion boundary	
5.3 Base metal and weld metal in or adjacent to the toe of complete joint penetration groove welded T or corner joints, or in complete joint penetration groove welded butt splices, with or without transitions in thickness having slopes no greater than 1:2.5 when weld reinforcement is not removed. (Note: cracking in the flange of the 'T' may occur due to out-of-plane bending stresses induced by the stem).	C	$44 \times 10^8$	10	From the surface discontinuity at the toe of the weld extending into the base metal or along the fusion boundary	
5.4 Base metal and weld metal at details where loaded discontinuous plate elements are connected with a pair of fillet welds or partial joint penetration groove welds on opposite sides of the plate normal to the direction of primary stress.	C as adjusted in Eq. 6.6.1.2.5-4	$44 \times 10^8$	10	Initiating from the geometrical discontinuity at the toe of the weld extending into the base metal or, initiating at the weld root subject to tension extending up and then out through the weld	

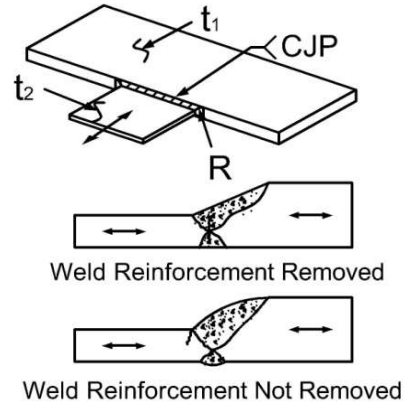
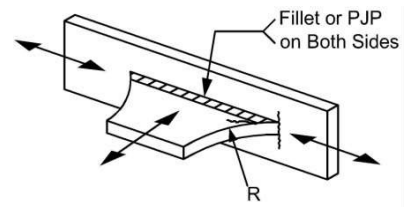
**Figure 6.4.43** AASHTO LRFD Bridge Design Specifications, 5<sup>th</sup> Edition, with 2010 Interim Revisions, Table 6.6.1.2.3-1 - Detail Categories for Load-Induced Fatigue, continued

Source: American Association of State Highway and Transportation Officials

Description	Category	Constant $A$ (ksi <sup>3</sup> )	Threshold $(\Delta F)_{TH}$ ksi	Potential Crack Initiation Point	Illustrative Examples
Section 6—Transversely Loaded Welded Attachments					
6.1 Base metal in a longitudinally loaded component at a transversely loaded detail (e.g. a lateral connection plate) attached by a weld parallel to the direction of primary stress and incorporating a transition radius $R$ with the weld termination ground smooth.  $R \geq 24$ in. $24$ in. $> R \geq 6$ in. $6$ in. $> R \geq 2$ in. $2$ in. $> R$ (Note: Condition 6.2, 6.3 or 6.4, as applicable, shall also be checked.)	B C D E	$120 \times 10^8$ $44 \times 10^8$ $22 \times 10^8$ $11 \times 10^8$	16 10 7 4.5	Near point of tangency of the radius at the edge of the longitudinally loaded component	
6.2 Base metal in a transversely loaded detail (e.g. a lateral connection plate) attached to a longitudinally loaded component of equal thickness by a complete joint penetration groove weld parallel to the direction of primary stress and incorporating a transition radius $R$ , with weld soundness established by NDT and with the weld termination ground smooth:  With the weld reinforcement removed:	B C D E	$120 \times 10^8$ $44 \times 10^8$ $22 \times 10^8$ $11 \times 10^8$	16 10 7 4.5	Near points of tangency of the radius or in the weld or at the fusion boundary of the longitudinally loaded component or the transversely loaded attachment	
With the weld reinforcement not removed:  $R \geq 24$ in. $24$ in. $> R \geq 6$ in. $6$ in. $> R \geq 2$ in. $2$ in. $> R$ (Note: Condition 6.1 shall also be checked.)	C C D E	$44 \times 10^8$ $44 \times 10^8$ $22 \times 10^8$ $11 \times 10^8$	10 10 7 4.5	At the toe of the weld either along the edge of the longitudinally loaded component or the transversely loaded attachment	

**Figure 6.4.43** AASHTO LRFD Bridge Design Specifications, 5<sup>th</sup> Edition, with 2010 Interim Revisions, Table 6.6.1.2.3-1 - Detail Categories for Load-Induced Fatigue, continued

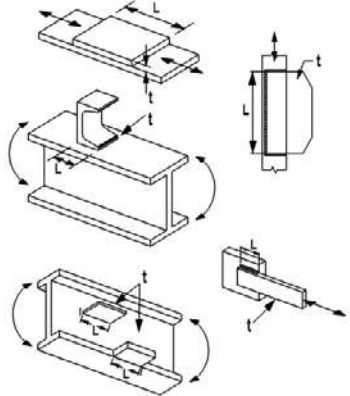
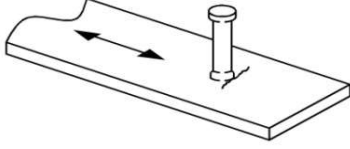
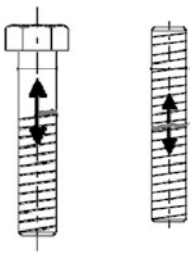
Source: American Association of State Highway and Transportation Officials

Description	Category	Constant $A$ (ksi <sup>3</sup> )	Threshold $(\Delta F)_{TH}$ ksi	Potential Crack Initiation Point	Illustrative Examples
<p>6.3 Base metal in a transversely loaded detail (e.g. a lateral connection plate) attached to a longitudinally loaded component of unequal thickness by a complete joint penetration groove weld parallel to the direction of primary stress and incorporating a weld transition radius <math>R</math>, with weld soundness established by NDT and with the weld termination ground smooth:</p> <p>With the weld reinforcement removed:</p> <p><math>R \geq 2</math> in.</p> <p><math>R &lt; 2</math> in.</p> <p>For any weld transition radius with the weld reinforcement not removed:</p> <p>(Note: Condition 6.1 shall also be checked.)</p>	<p>D</p> <p>E</p> <p>E</p>	<p><math>22 \times 10^8</math></p> <p><math>11 \times 10^8</math></p> <p><math>11 \times 10^8</math></p>	<p>7</p> <p>4.5</p> <p>4.5</p>	<p>At the toe of the weld along the edge of the thinner plate</p> <p>In the weld termination of small radius weld transitions</p> <p>At the toe of the weld along the edge of the thinner plate</p>	
<p>6.4 Base metal in a transversely loaded detail (e.g. a lateral connection plate) attached to a longitudinally loaded component by a fillet weld or a partial joint penetration groove weld, with the weld parallel to the direction of primary stress</p> <p>(Note: Condition 6.1 shall also be checked.)</p>	<p>See Condition 5.4</p>				

**Figure 6.4.43** AASHTO LRFD Bridge Design Specifications, 5<sup>th</sup> Edition, with 2010 Interim Revisions, Table 6.6.1.2.3-1 - Detail Categories for Load-Induced Fatigue, continued

Source: American Association of State Highway and Transportation Officials



Description	Category	Constant $A$ (ksi <sup>3</sup> )	Threshold $(\Delta F)_{TH}$ ksi	Potential Crack Initiation Point	Illustrative Examples
Section 7—Longitudinally Loaded Welded Attachments					
7.1 Base metal in a longitudinally loaded component at a detail with a length $L$ in the direction of the primary stress and a thickness $t$ attached by groove or fillet welds parallel or transverse to the direction of primary stress where the detail incorporates no transition radius:				In the primary member at the end of the weld at the weld toe	
$L < 2$ in.	C	$44 \times 10^8$	10		
$2$ in. $\leq L \leq 12t$ or 4 in.	D	$22 \times 10^8$	7		
$L > 12t$ or 4 in.					
$t < 1.0$ in	E	$11 \times 10^8$	4.5		
$t \geq 1.0$ in.	E'	$3.9 \times 10^8$	2.6		
Section 8—Miscellaneous					
8.1 Base metal at stud-type shear connectors attached by fillet or automatic stud welding	C	$44 \times 10^8$	10	At the toe of the weld in the base metal	
8.2 Nonpretensioned high-strength bolts, common bolts, threaded anchor rods and hanger rods with cut, ground or rolled threads. Use the stress range acting on the tensile stress area due to live load plus prying action when applicable.				At the root of the threads extending into the tensile stress area	
(Fatigue II) Finite Life	E'	$3.9 \times 10^8$	N/A		
(Fatigue I) Infinite Life	D	N/A	7		

Footnote:  
 TH = Threshold

**Figure 6.4.43** AASHTO LRFD Bridge Design Specifications, 5<sup>th</sup> Edition, with 2010 Interim Revisions, Table 6.6.1.2.3-1 - Detail Categories for Load-Induced Fatigue, continued

Source: American Association of State Highway and Transportation Officials

### 6.4.6

#### **Fracture Critical Bridge Types**

The following is a list of steel bridge superstructure members and connections which are susceptible to fatigue cracking and possible failure:

- Two-girders systems (see Topic 10.2)
- Box beams and girders (see Topic 10.3)
- Trusses (see Topic 10.4)
- Arches (see Topic 10.5)
- Rigid frames (see Topic 10.6)
- Pin and hanger assemblies (see Topic 10.3)
- Gusset plates (see Topic 10.8)
- Eyebars (see Topic 10.9)
- Cable supported bridges (see Topic 16.1)
- Movable bridges (see Topic 16.2)
- Floating bridges (see Topic 16.3)

Fatigue cracks can develop in steel bridges as a result of repeated loading. Generally, the stress range, number of cycles and type of detail are the most important factors that influence fatigue cracking. Recognizing and understanding the behavior of connections and details is crucial if the inspector is to properly inspect FCMs. Connections and details are often the locations of highest stress concentrations.

### 6.4.7

#### **Fracture Criticality**

Cracks and fractures have occurred in a large number of steel bridges. A report, *Manual for Inspecting Bridges for Fatigue Damage Conditions*, was prepared in 1990 under the support of the Pennsylvania Department of Transportation and the Federal Highway Administration to aid in the inspection of bridges. It summarizes the basic information on fatigue strength of bridge details and contains examples and illustrations of fatigue damage in welded, bolted, and riveted structures. A number of case histories are contained in *Fatigue and Fracture in Steel Bridges - Case Studies*, by John W. Fisher. *Fatigue Cracking of Steel Bridge Structures*, published by the Federal Highway Administration (FHWA) in March 1990, also contains valuable case studies of actual bridges. These three publications are listed in the Bibliography.

There are many factors which influence the fracture criticality of a bridge with FCMs, including:

- The degree of redundancy
- The live load member stress range
- The propensity of the material to crack or fracture
- The condition of specific FCMs
- The existence of fatigue prone and problematic design details
- The previous number and size of loads

- The predicted number and size of loads

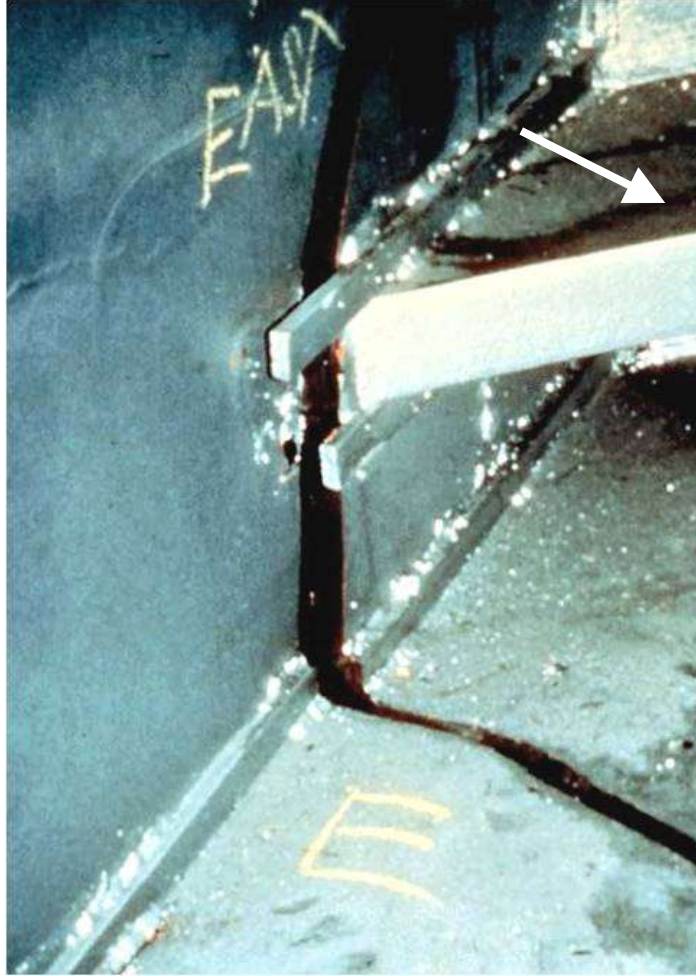
**Details and Deficiencies** Carefully inspect more susceptible low fatigue strength details, such as AASHTO Fatigue Category D through E' details on fracture critical bridges (see Figure 6.4.44). Be aware of bridges that may have experienced large truck volumes and/or magnitude of stress cycles.



**Figure 6.4.44** Riveted Gusset Plate Connection

#### Initial Deficiencies

Initial deficiencies, in many cases, are cracks resulting from poor quality welds between attachments and base metal (see Figure 6.4.45). Many of these cracks occurred because the groove-welded element was considered a “secondary” attachment with no established weld quality criteria (e.g., splices in longitudinal web stiffeners or back-up bars). Intersecting welds can provide a path for the crack to travel between steel members (see Figure 6.4.46).



**Figure 6.4.45** Poor Quality Welds Inside Cross Girder



**Figure 6.4.46** Intersecting Welds

## 6.4.8

### **Inspection Methods and Locations**

While FCMs are to be given special attention, take care to assure that the remainder of the bridge or non-fracture critical members are not ignored and that they are also inspected thoroughly. Bridge plans and shop drawings for bridges designed after about 1980 are to have FCMs clearly identified. If FCMs are not clearly identified, use the guidelines previously described in this Topic along with the aid of a structural engineer to determine FCMs.

According to the National Bridge Inspection Standards, a fracture critical member inspection is defined as a hands-on inspection of a fracture critical member or member components that may include visual and other nondestructive evaluation. FCM inspections are to be performed at intervals not to exceed twenty-four months. Certain FCMs may require a frequency of less than twenty-four months. Establish criteria to determine the level and frequency of these inspections based on such factors as age, traffic characteristics, AASHTO fatigue categories, and known deficiencies.

#### **Methods**

##### **Visual**

The inspection of steel bridge members for deficiencies is primarily a visual activity. Most deficiencies in steel bridges are first detected by visual inspection. In order for this to occur, a hands-on inspection, or inspection where the inspector is close enough to touch the area being inspected, is required. More exact visual observations can also be employed by cleaning suspect areas, removing paint when necessary, and using a magnifying unit.

##### **Physical**

Smaller cracks are not likely to be detected visually unless the paint, mill scale, and dirt are removed by carefully cleaning the suspect area. If the confirmation of a possible crack is to be conducted by another person, it is advisable not to disturb the suspected crack area so that re-examination of the actual conditions can be made.

Removal of paint can be done using a wire brush, grinding, or sand blasting, depending on the size and location of the suspected deficiency. Take care in cleaning when the suspected deficiency is a crack. When cleaning steel surfaces, avoid any type of cleaning process, such as blasting or excessive grinding which may tend to close the crack. The use of degreasing spray before and after removal of the paint may help in revealing the deficiency.

When section loss occurs, use a wire brush, grinder or hammer to remove loose or flaked steel. After the flaked steel is removed, measure the remaining section and compare it to a similar section with no section loss.

The usual and most reliable sign of fatigue cracks is the oxide or rust stains that develop after the paint film has cracked. Experience has shown that cracks have generally propagated to a depth between one-fourth and one-half the plate thickness before the paint film is broken, permitting the oxide to form. This occurs because the paint is more flexible than the underlying steel.

Once the presence of a fatigue crack has been verified, examine all other similar locations and details.

### **Advanced Inspection Methods**

Several advanced methods are available for steel inspection. Nondestructive methods, described in Topic 15.3.2, include:

- Acoustic emissions testing
- Corrosion sensors
- Smart coatings
- Dye penetrant
- Magnetic particle
- Radiography testing
- Computed tomography
- Robotic inspection
- Ultrasonic testing
- Eddy current
- Electrochemical fatigue sensor (EFS) (detects fatigue growth)
- Magnetic flux leakage (external PT tendons and stay cables)
- Laser vibrometer (for stay cable vibration measurement and cable force determination)

Other methods for determining material properties, described in Topic 15.3.3, include:

- Brinell hardness test
- Charpy impact test
- Chemical analysis
- Tensile strength

### **Inspection of Details**

Focus fracture critical member inspection on those details that are most susceptible to fatigue problems.

Of all the details, those of AASHTO fatigue Categories D through E' are the most susceptible to fatigue crack growth. If Category D, E or E' details are found on a FCM, carefully inspect them during each inspection and their presence clearly documented in the inspection report.

### **Recordkeeping and Documentation**

The consequences of deficiencies on bridges with FCMs can be very serious. The ability to verify a deficiency at the bridge site or to correctly evaluate it in the office depends on the proper recording and documenting of field conditions. Since many deficiencies become obvious only as time passes, complete, clear, and concise recordkeeping provides a valuable reference for comparison in future bridge inspections.

When a deficiency is encountered in a FCM, record relevant information carefully and thoroughly, including:

- Method of inspection: visual, physical or advanced (see Topics 6.3 and

15.3)

- The date the deficiency was detected, confirmed, and re-examined
- The type of deficiency, such as cracks, notches, nicks, or gouges, deficiencies in welds, excessive corrosion, or apparent distortion, mislocation, or misalignment of the member
- The general location of the deficiency, such as “at Panel Point L5 of the downstream truss” or “at the lower end of connection plate of Floorbeam No. 4 to the north girder of the eastbound bridge”
- Detailed sketches of the location, shape, and size of the deficiency; give extra care to determine the location of the ends of cracks
- The dimensions and details of the member containing the deficiency, including sketches and/or photographs
- Any noticeable conditions at cracks when vehicles traverse the bridge, such as opening and closing of the crack or visible distortion of the local area
- Any changes in shape or condition of adjacent elements or members
- The presence of corrosion or the accumulation of dirt and debris at the general location of the deficiency
- Weather conditions when the deficiency was discovered or inspected

Label the member using paint or other permanent markings: mark the ends of the crack, the date, and compare to any previous markings. Coordinate with the bridge owner to see what is acceptable to mark on the bridge. Be sensitive to aesthetics at prominent areas. Photograph and sketch the member and the deficiency.

Refer to Topics 4.4 and 4.6 for general record keeping, documentation and inspection report writing.

### **Recommendations**

When deficiencies are encountered in FCMs, the repair of the condition generally demands a high priority. List the deficiencies and required repairs in order of priority. For example, a crack in a flange is more significant than surface corrosion of the web. There are two general classifications for repairs of FCMs:

**Urgent repairs** - repairs that are required immediately in order to maintain the life of the structure or to keep the bridge open; these repairs are for bridge-threatening deficiencies. Urgent repairs are considered to be a critical finding. See Topic 4.5 for detail explanation of critical findings and appropriate plans of action.

**Programmed repairs** – may be worked into the normal maintenance schedule; these repairs are for non-threatening deficiencies and activities such as cleaning and painting of structural steel

## Locations

## Problematic Details

Problematic details may exist on a variety of steel bridges such as girder, frame, truss superstructures, and substructure components. The following are problematic details, which can lead to fatigue cracking:

- Triaxial constraint
- Intersecting welds
- Cover plates
- Cantilevered suspended span
- Insert plates
- Field welds: patch and splice plates
- Intermittent welds
- Out-of-plane bending
- Pin and hanger assemblies
- Back-up bars
- Mechanical fasteners and tack welds

### Triaxial Constraint

Triaxial constraint leads to plastic constraint and brittle fracture. This fracture condition can be produced by a narrow gap between the gusset plate and transverse connection/stiffener plate (see Figure 6.4.47). Elastic stress results indicate that triaxial constraint will prevent yielding of the steel until the stress exceeds approximately 1.3 times the yield strength of the material. Under high plastic constraint, local stresses can reach 2 to 3 times the average stress.



**Figure 6.4.47** Local Triaxial Constraint Condition Resulting in Fracture on the Hoan Bridge, Milwaukee, Wisconsin